

MADE
LIKE A
GUN

ROYAL ENFIELD
MOTOR CYCLES

1914



THE ENFIELD CYCLE CO.
LIMITED **REDDITCH.**

**Contractors to H.M. Government, Army, Navy, and
Reserve Forces.**

Showrooms

48 HOLBORN VIADUCT, LONDON, E.C.

Directors:

LORD ERNEST SEYMOUR (Chairman).
GEORGE HOWARD CARTLAND.
THOMAS EVANS.

Managing Director:

ROBERT WALKER SMITH, M.I.M.E.

Bankers:

METROPOLITAN BANK (OF ENGLAND
AND WALES), LTD.

Solicitors:

TUNBRIDGE & CO., Redditch and Birmingham.

Auditors:

AGAR, BATES, NEAL & CO.,
Birmingham and London.

Commercial Manager and Secretary

T. C. PATCHETT.

Telephones: Nos. 121, 122 & 123, REDDITCH. No. 424 HOLBORN.
Telegrams: "CYCLES, REDDITCH." "JIGGER, CENT. LONDON."

A Rocky Ride on a 6 h.p. Royal Enfield.

First Ascent of Table Mountain (Cape Town).

- (1) Detaching the sidecar at the foot of Diamond Spring Path.
- (2) A skid on Diamond Spring Path due to loose surface on a right angled bend. The gradient at this point is 1 in 6.
- (3) One of the many narrow riding tracks with a surface of loose stones and a drop of several hundred feet on the outside.
- (4) The Back Table—2,400 feet above sea level.
- (5) A reed grass track on the Back Table.
- (6) Wynberg Reservoir—one of five on the plateau on the top of Table Mountain.



The Rider is Mr. D. Garlick of Cape Town, a well-known South African motor cyclist — the motor cycle a 6 h.p. Royal Enfield.

Photographs by courtesy of "The Motor Cycle."



ROYAL ENFIELD MOTOR CYCLES

FOR

1914

IT is with a considerable amount of pride—which in the circumstances is perhaps pardonable—that we place on record the fact that the first Royal Enfield motor vehicle was constructed in 1897. There are few firms in the motor cycle industry to-day who can date back their experience so far, but those able to do so are easily recognised as the most successful of all. We mention this because it shows the wide knowledge we have of motor cycles from their very inception.

Motor cycling has passed through many phases since 1897, but from that time onwards Royal Enfield motor cycles have always been abreast of the times in every point making for efficiency and satisfaction in service. Dealing with the past year only, it will be seen, by referring to the list of successes achieved on Royal Enfields, that performances have been accomplished which but a short time ago would have been thought incredible. Both on the road and track, and at home and abroad, Royal Enfields have clearly demonstrated their exceptional speed and reliability.

In the Royal Enfield productions, reliability is studied first and foremost; at the same time, our long list of brilliant performances is tangible proof that speed is also embodied in a remarkable degree.

For 1914 we still adhere to the twin-cylinder engine, the famous Royal Enfield countershaft Two-speed and free-engine gear—than which none more reliable has ever been evolved—and Chain Drive in conjunction with the Enfield Patent Cush Drive Rear Hub. Four models are now manufactured, all of which embody these special features.

The Royal Enfield Works.

In our introduction to the 1913 Royal Enfield motor cycle catalogue we mentioned, with a certain amount of gratification, that the demand for Royal Enfield motor cycles had made it necessary we should increase our factory facilities. In introducing our 1914 catalogue, we are pleased to say that, so great has been the demand during the previous year, further extensions have again been necessary.

The main machine shop at our Redditch factory—already one of the largest of its kind—has been greatly extended and enlarged. New machinery of the very latest type is constantly being installed. A new block of buildings for our motor sundries department is also in course of erection, and with these alterations we feel that we shall be in a position to satisfy the huge demand which we confidently anticipate for our 1914 models.

We repeat what we have said in previous years regarding the careful supervision of all processes of manufacture in the Royal Enfield works. Excellence of workmanship allied to excellence of design has always been the Royal Enfield aim. That we have succeeded we will leave our customers, both present and prospective, to judge for themselves. The list of successes contained in this catalogue, and the reproduction of a few of our many testimonials on pages 28 and 29, will, we feel sure, help them to arrive at their decision.

Looking down one of the large Machine Shops at the Royal Enfield Works, Redditch.

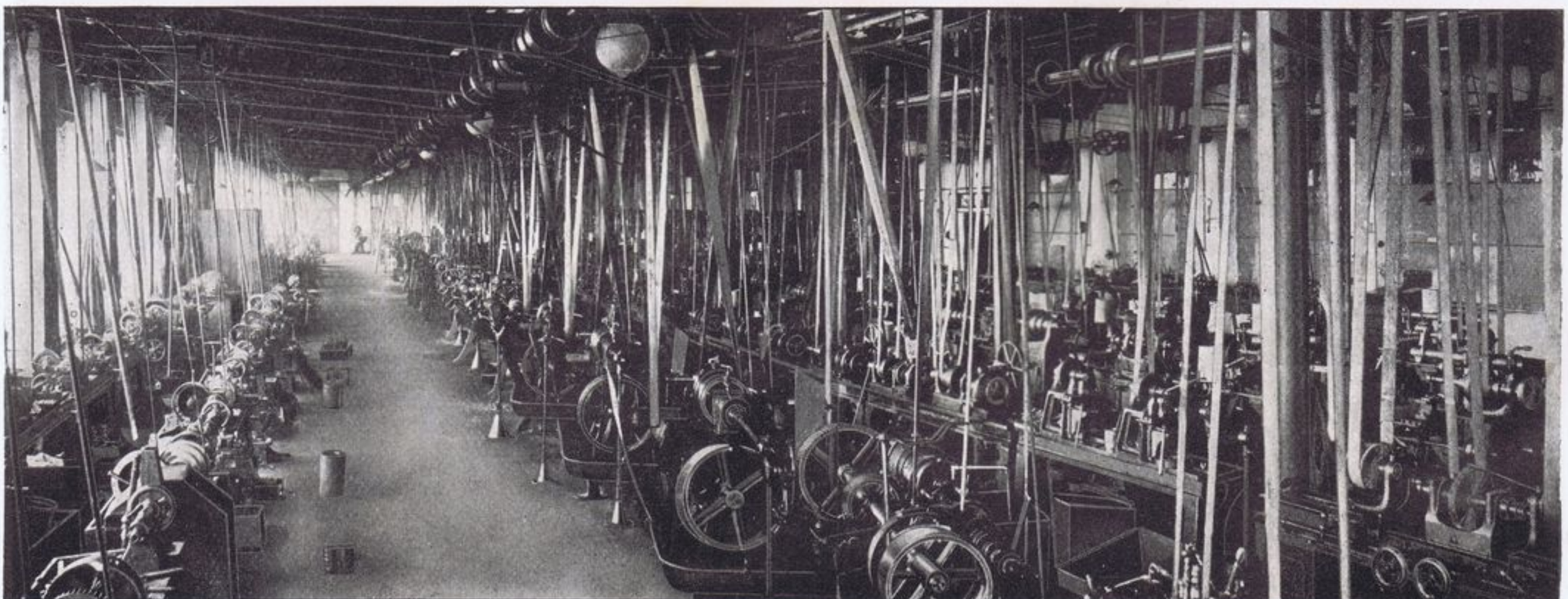

Competition Successes.

The list of successes achieved on Royal Enfield motor cycles during 1913, given on pages 30 and 31 (also 6 and 7), represents only the more important trials and competitions which have actually been won on our motor cycles. It would need considerably more space than we have at our disposal to refer in detail to all the honours and awards which have fallen to Royal Enfields during the past few years.

One very pertinent point we must mention in this respect. Certain other makes of motor cycles achieve little success except when ridden by expert professional trade riders, who frequently compete on specially constructed machines. The majority of the Royal Enfield successes have been won by genuine private owners riding standard pattern Royal Enfield motor cycles. The importance of this cannot be overlooked; it stamps Royal Enfields with a standard of excellence absolutely uniform in every single machine.



Members of the Green Street Green (Kent) Fire Brigade.
It is a Standard 6 h.p. Royal Enfield Side-car Combination.
**We do not advise this overloading but—
Royal Enfield reliability is equal to it.**

Helps for Royal Enfield Riders.

We publish carefully compiled handbooks dealing with all our models, and these we supply free to Royal Enfield riders. These books represent the outcome of years of experience in motor cycling, and smooth away any difficulties which the motor cycling novice may encounter. Further, the experienced rider will find these books of valuable assistance when undertaking any adjustments to his motor cycle, and the thoroughness with which they are prepared has evoked the most lavish praise from motor cycling critics and experts in all parts of the world.

Royal Enfield Agents.

In nearly every town and village in the United Kingdom an accredited Royal Enfield motor cycle agent is to be found. Our agents are fully conversant with all the details of the Royal Enfield models, and will gladly demonstrate on any points pertaining to them. We shall be pleased to furnish to motor cyclists in any part of the world the name and address of the nearest Royal Enfield agent.

A Performance which proves the Superiority of the 3 h.p. Royal Enfield for Sustained Riding at Speed

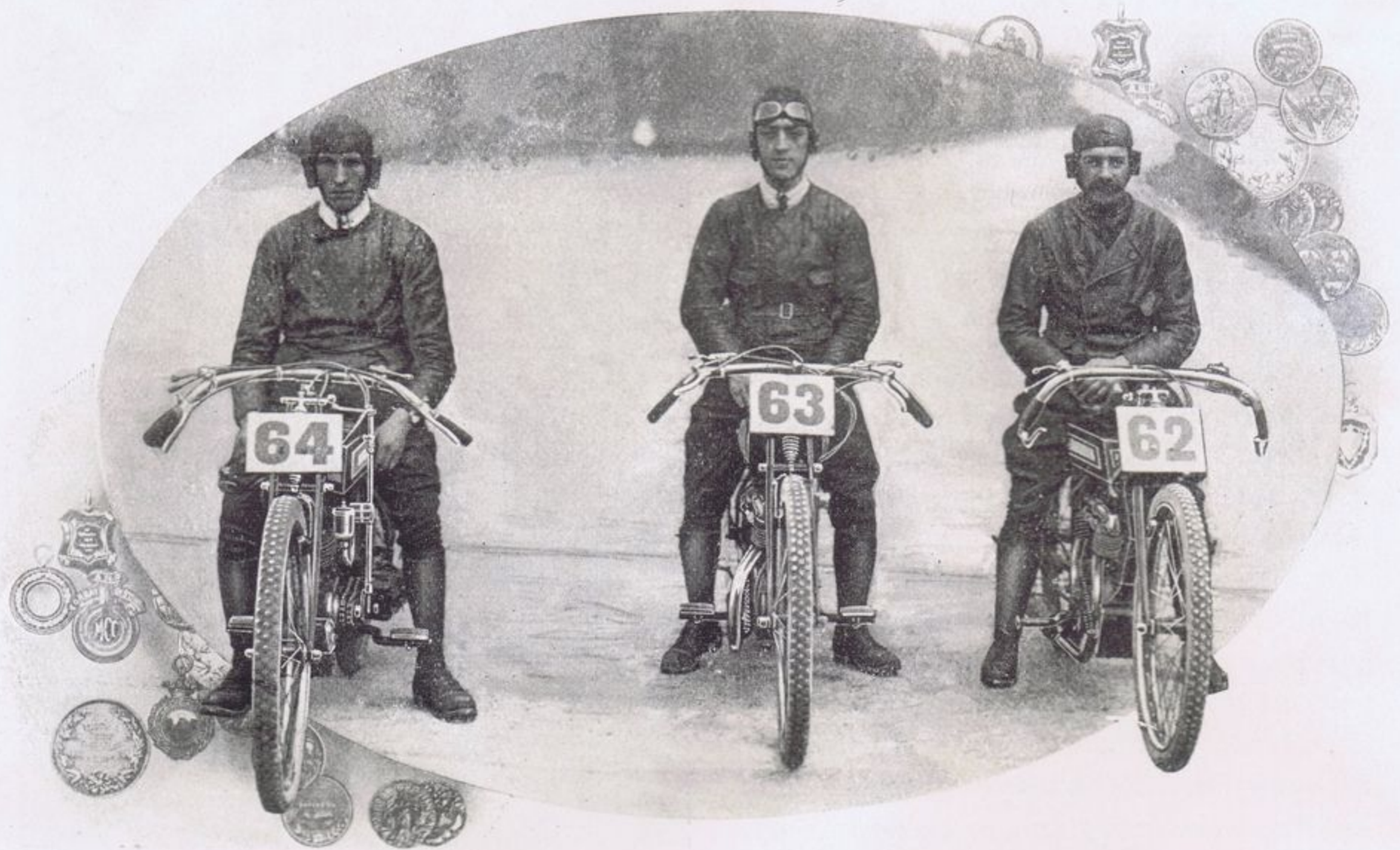

Messrs. Keyte, Greaves, and Colver, all on 3 h.p. Enfield Models, who finished second, third, and fourth in the Six Hours' Race—remarkable consistency.

Unprecedented 3 h.p. Enfield Team Performance.

OPEN SIX HOURS' RACE (350 c.c. Class), B.M.C.R. Club Meeting,
July 16th, 1913.

THREE 3 h.p. ROYAL ENFIELDS competed.

THREE 3 h.p. ROYAL ENFIELDS finished.

THREE 3 h.p. ROYAL ENFIELDS
Broke Previous Six Hours' Record.

Distances Covered.

2nd in Race, ...	H. V. Colver, 3 h.p. Enfield	302 miles, 1,521 yards.
3rd ,, ...	E. H. Keyte, 3 h.p. Enfield	281 ,, 893 ,,
4th , ...	H. Greaves, 3 h.p. Enfield	279 ,, 648 ,,

Fully recognising this marvellous performance, the Brooklands Motor Cycle Racing Club awarded Three Special Gold Medals to the successful Enfield riders.

The remarks at the foot of the following page, *re* engine capacity, apply also to the 3 h.p. Royal Enfields ridden in the above race.

BARNSTORMERS.CO.NZ

The most brilliant Victory of the Year. The 3 h.p. Royal Enfield Team vanquishes "all comers."



Messrs. Colver, Greaves, and Iron, whose 3 h.p. Enfields covered 155 miles between them, thus winning the One Hour Team Race against all comers—a remarkable performance.

What the Royal Enfield Team accomplished. ONE HOUR TEAM RACE, B.M.C.R.C. Meeting, September 13th, 1913.

Total Distance covered.

1st—Enfield 3 h.p. Team 155 miles 684 yards.

2nd—*—Team (one 7 h.p., two 3½'s)	—	129	..	1,730	..
3rd—*—Team (three 3½'s)	—	120	..	523	..
4th—*—Team (three 3½'s)	—	106	..	199	..

In two teams only two of the riders finished, in one team only one rider finished, but in the winning Royal Enfield team all three riders finished without a hitch or a semblance of trouble.

The engines fitted to the 3-h.p. Enfields for this race were of 350 c.c., actually 75 c.c. smaller than our Standard 3-h.p. engine. These engines were made smaller for this race because it was originally intended to divide it into classes—for engines under 350 c.c., under 500 c.c., and any size over. This makes the Royal Enfield performance all the more remarkable, as Standard size engines, being of larger capacity, would naturally have improved upon these distances.

BARNSCORMERS.CO.NZ

The $2\frac{3}{4}$ h.p. Royal Enfield.

THE first INDIAN TOURIST TROPHY RACE—a terrible ride over rough, boulder strewn roads, far worse than anything imaginable in this country—was won on a Standard $2\frac{3}{4}$ h.p. Royal Enfield Motor Cycle, exactly the same as the model illustrated opposite.

This Model was the first motor cycle of its class; and, although to-day it has its imitators in profusion, it still ranks as the best solo motor cycle at the price.

Both in design and construction the $2\frac{3}{4}$ h.p. Royal Enfield is built with the sole idea of giving absolutely reliable service. In proof of this, the testimonial reprinted (by permission) on page 28 will convey an idea of the splendid satisfaction these models afford. It is a typical testimonial from the very large number we have received.

Like all Royal Enfields, the $2\frac{3}{4}$ h.p. Model is fitted with the Enfield Patent Two-Speed Countershaft Gear, Cush Drive Rear Hub and Chain Transmission. It has an efficient Kick-starter, and the riding position is most comfortable.

The full specification is given on the following page; its special features being more completely illustrated and described on pages 22 and 23. The price of £45 includes everything shown in our illustration, the machine being turned out ready for the road.

Royal Enfield 2 $\frac{3}{4}$ h.p. Two-speed and Free Engine Model. Model 160.

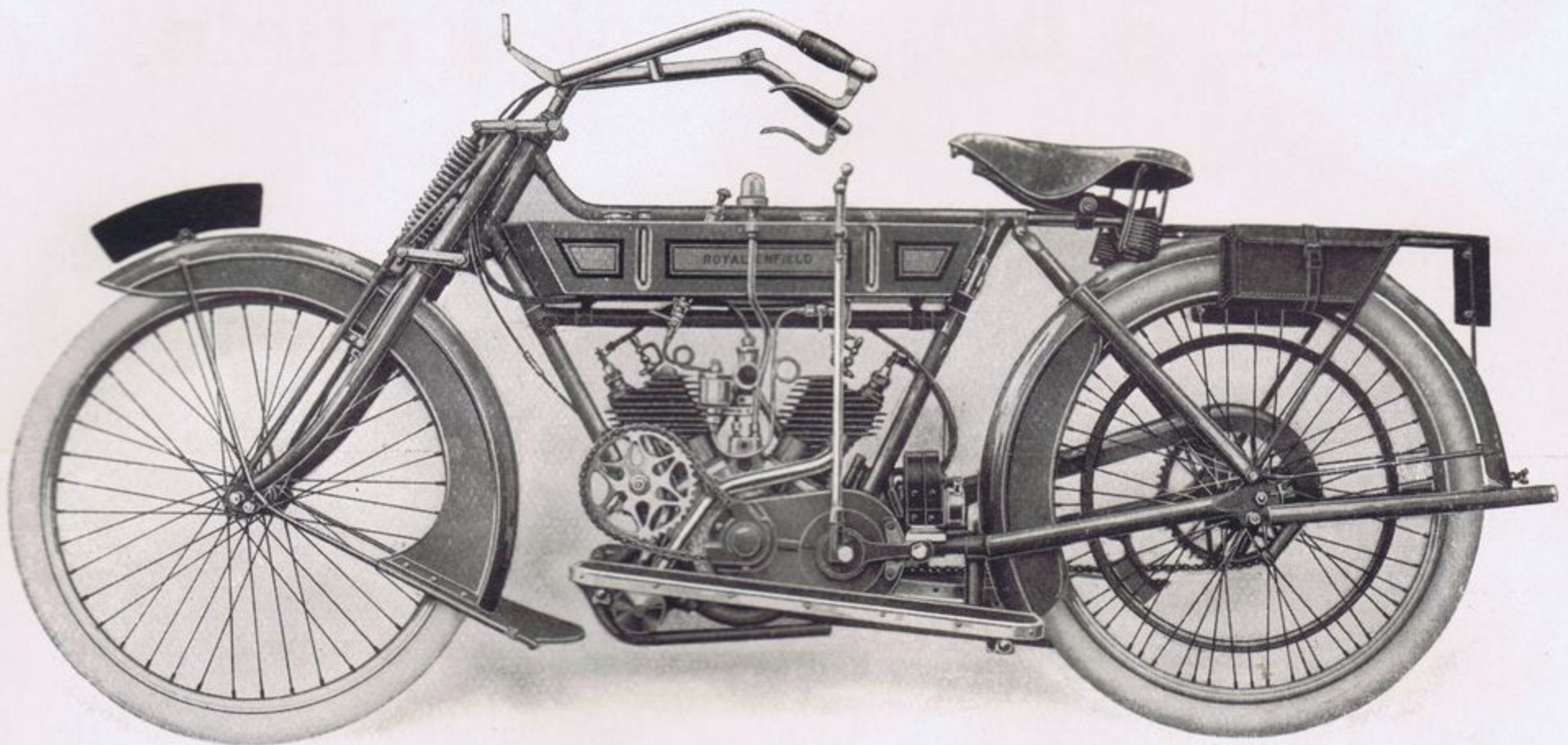

SPECIFICATION.

- Engine** - - - - Royal Enfield twin cylinder, bore and stroke 54 by 75 m/m ; mechanically operated inlet valves.
- Two-Speed and Free Engine Gear.** Royal Enfield patent design, expanding clutch type.
- Transmission** - - Roller chains, $\frac{1}{2}$ in. pitch, in conjunction with Royal Enfield Cush Drive Hub.
- Cush Drive Hub** - The Royal Enfield Patent Cush Drive Hub (see page 20) is fitted.
- Kick-Starter** - - An entirely new type of "kick-starter" is fitted, working direct on the driving shaft by a ratchet clutch.
- Ignition** - - - - Latest Bosch magneto ; waterproof terminals.
- Carburetter** - - - AMAC multiple jet.
- Lubrication** - - - Automatic visible drip feed (see page 23) and auxiliary hand pump.
- Tank** - - - - Two compartments, registered fitting supports which obviate any possibility of leakage. Petrol capacity, 1 $\frac{1}{4}$ gallons ; oil capacity, 1 quart.
- Frame** - - - - Royal Enfield design, exceptionally low, but with plenty of ground clearance ; fitted with footboards and registered pattern spring front forks.
- Tyres** - - - - Dunlop studded, front 26in. by 2in. ; rear 26in. by 2 $\frac{1}{4}$ in.
- Mudguards** - - - Strong and wide, front extension, side shields on both guards, and mud flap.
- Carrier** - - - - Made of specially strong steel tube.
- Stands** - - - - Stands both for front and rear wheels fitted.
- Handlebar** - - - Royal Enfield, registered design ; concealed cables through handlebar.
- Brakes** - - - - Powerful inverted lever front rim brake, rear brake operated by foot pedal.
- Saddle** - - - - Well sprung, with large leather seat.
- Toolbags** - - - Two leather pannier bags, containing complete set of tools.
- Finish** - - - - Enamelled in Naval Grey, a particularly attractive colour, which wears exceptionally well, and defies both dust and mud. Bright parts heavily plated and polished.

Price

The 3 h.p. Royal Enfield.

THE 3 h.p. Royal Enfield stands in an unassailable position as the solo motor cycle *par excellence*. Its remarkable performances at Brooklands during 1913, referred to on pages 6 and 7, would have been thought incredible two years ago.

The twin-cylinder engine is fitted with overhead inlet valves and perfectly straight induction pipes, giving a clear access of gas from the carburetter. The lubrication is by a mechanical forced-feed system, which ensures proper oil supply at all speeds. Besides keeping the engine always up to a point of the highest efficiency, this system enables us to provide a special oil tank at the rear of the seat tube.

For solo riding the 3 h.p. Royal Enfield is fitted with every feature that experience can suggest and skill devise. Moreover, the price, including everything mentioned in the specification, is actually lower than the majority of Two-speed Motor Cycles of similar power.

The specification is given opposite, and its most important features are fully dealt with on pages 24 and 25. The testimonials on pages 28 and 29 relating to this model should be carefully read.

3 h.p. Royal Enfield Two-speed and Free Engine Model.

Model 140.

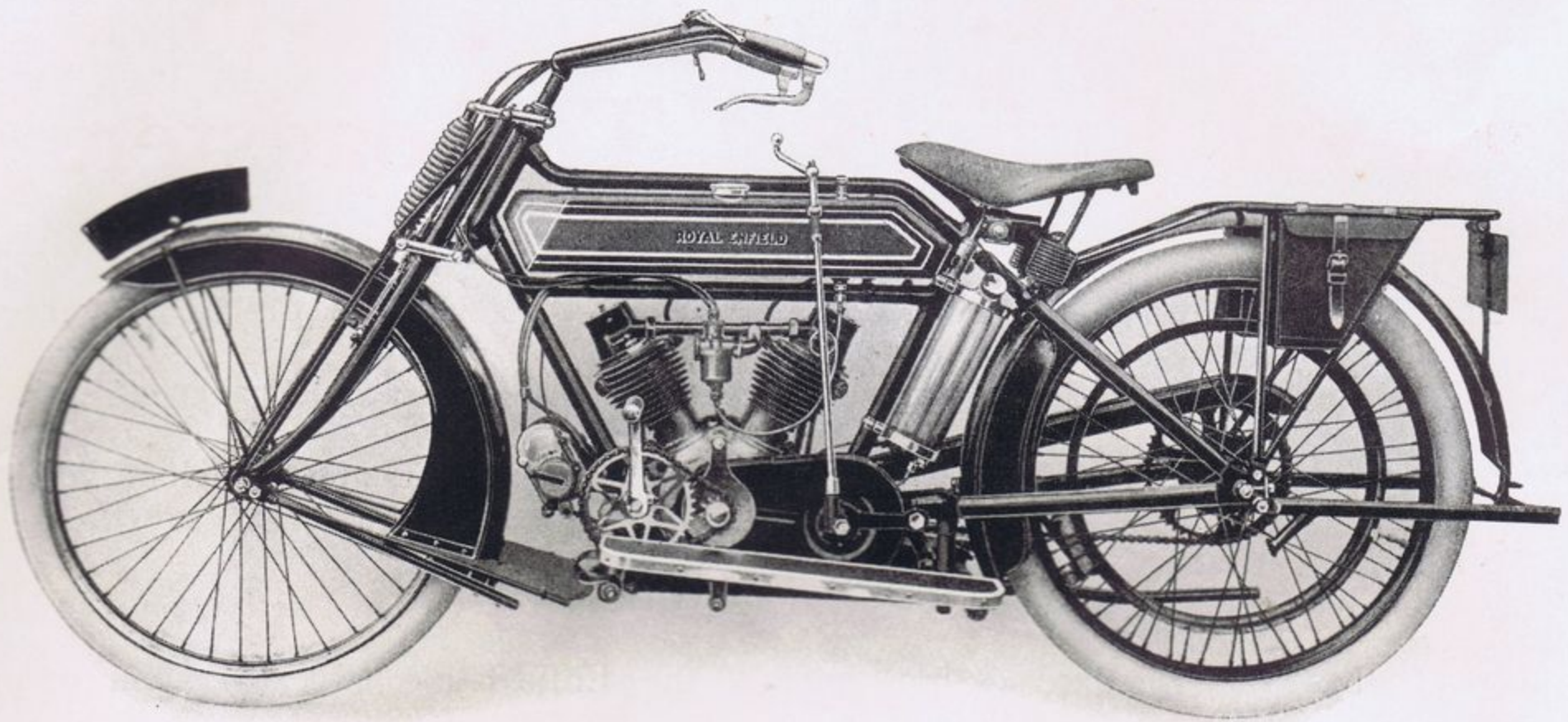

SPECIFICATION.

- Engine** - - - - Royal Enfield twin cylinder 60 x 75 m/m, M.O., overhead inlet valves. working parts completely enclosed and dust-proof.
- Two-Speed and Free Engine Gear.** Royal Enfield patent design; expanding clutch type.
- Kick-Starter** - - New type of kick-starter, working direct on the driving shaft.
- Transmission** - - Roller chains, Hans Renolds extra heavy, ½ in. pitch, in conjunction with the Royal Enfield cush drive hub.
- Cush Drive Hub** - The Royal Enfield patent Cush Drive Hub is fitted. (See page 20).
- Ignition** - - - New Bosch waterproof magneto, chain driven. Controlled from handlebar.
- Carburetter** - - AMAC multiple jet.
- Lubrication** - - Royal Enfield patent mechanical forced-feed lubrication system. Fully described on page 25.
- Tank** - - - - Fitted with large glass-topped filler, gauze strainer, and needle valve to regulate flow of petrol. Lubricating oil is carried in separate tank. Petrol capacity, 1½ gallons.
- Frame** - - - - Royal Enfield loop frame, dropped at back to give low saddle position; fitted with spring footboards and registered pattern spring forks.
- Mudguards** - - Strong and wide, front extension; side shields on both guards, and mud flap.
- Tyres** - - - - Palmer Cord, 26 in. x 2¼ in.
- Handle-bar** - - Royal Enfield registered design, concealed cables through handle-bar, carburetter and ignition controls and lamp bracket integral with bar.
- Brakes** - - - - Powerful inverted lever front rim brake; rear brake operated by foot pedal.
- Saddle** - - - - Brooks' B170, specially large and well-sprung.
- Tool Bags** - - Two leather pannier bags, containing complete set of tools.
- Carrier** - - - - Made from weldless tubular steel and strongly attached.
- Stands** - - - - Two stands fitted (one for each wheel). Both fasten securely with spring clips.
- Finish** - - - - Enamelled in best black enamel, tank artistically panelled in two shades of green. Bright parts heavily plated.
- Price**

The 3 h.p. Royal Enfield T.T. Roadster.

THIS new Royal Enfield Model follows very closely the design of our Standard 3 h.p. Motor Cycle referred to on the preceding page, except that it is built as a "T.T. Roadster" Model. It is the ideal machine for competition riding.

It has the standard 3 h.p. engine, the Enfield mechanical system of forced-feed lubrication, the Enfield Patent Two-speed and Free-engine Countershaft Gear, Chain Transmission, and the Patent Cush Drive Rear Hub. In addition, it has a new type of semi "T.T." handlebar, which we have specially designed for this model. It is illustrated on page 24. A Senspray Carburetter is fitted, as we believe this carburetter gives the best results at speed.

It will be noticed that the front mudguard is of a specially light pattern, and that short foot-boards are fitted. In all other respects this "T.T." Model embodies the same strength of construction and the same reliability which is so characteristic of the Standard 3 h.p. machine.

The particulars given on pages 24 and 25 in regard to our Standard 3 h.p. Motor Cycle also apply to this "T.T." Model, except as regards the carburetter (specially referred to above) and the Kick-starter (which is omitted on this Model).

3 h.p. Royal Enfield T.T. Roadster Model.

Model 150.

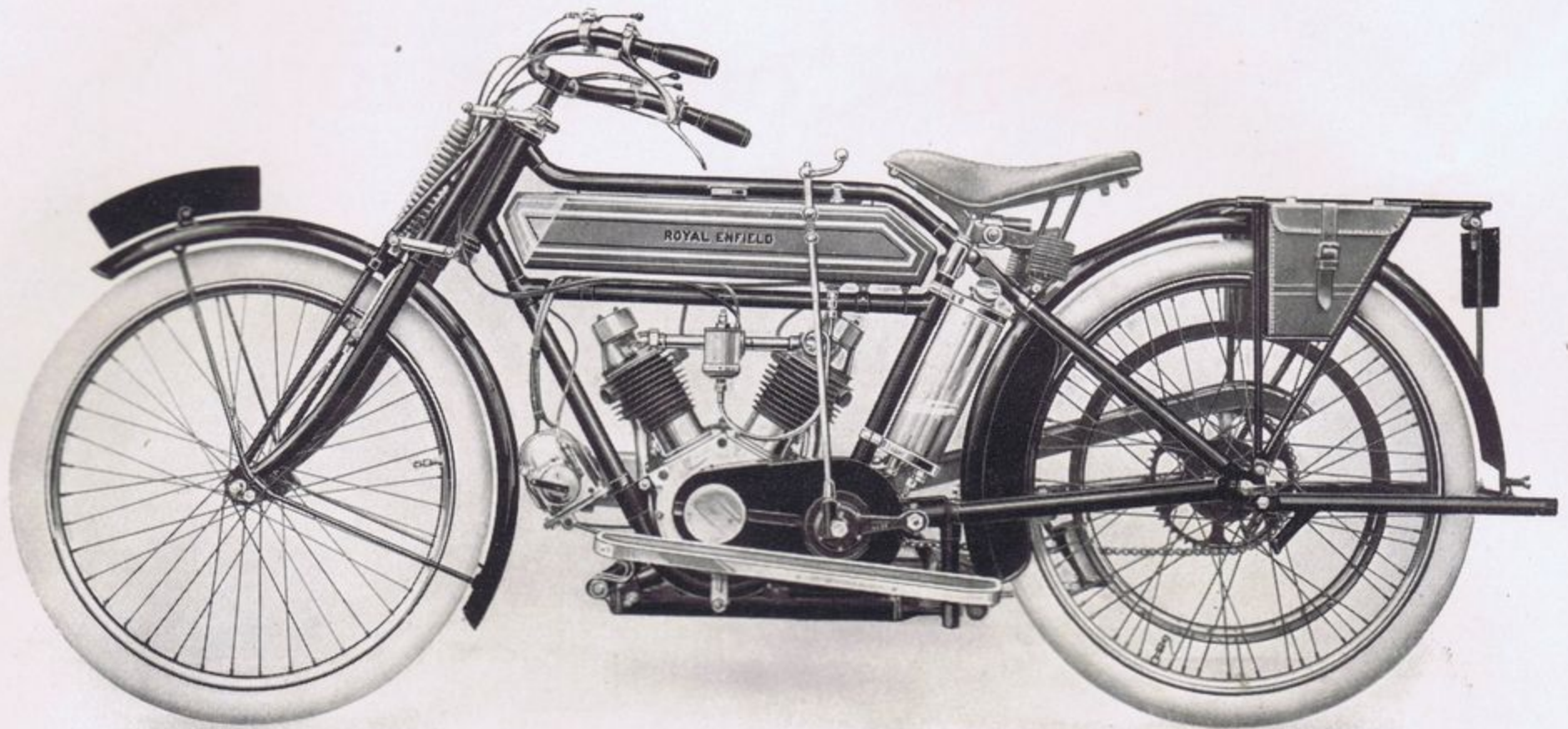

SPECIFICATION.

- Engine** - - - - Royal Enfield twin cylinder, 60 x 75 m/m; M.O. overhead inlet valves, with working parts completely enclosed and dust-proof.
- Two-Speed and Free Engine Gear.** Royal Enfield patent design; expanding clutch type.
- Transmission** - - Roller chains, Hans Renolds extra heavy, $\frac{1}{2}$ in. pitch, in conjunction with the Royal Enfield cush drive rear hub.
- Cush Drive Hub** - The Royal Enfield patent Cush Drive Hub is fitted. (See page 20.)
- Ignition** - - - - New Bosch waterproof magneto, chain driven. Controlled from handlebar.
- Carburetter** - - - Latest pattern Senspray.
- Lubrication** - - - Royal Enfield patent mechanical forced-feed lubrication system. Fully described on page 25.
- Tank** - - - - Fitted with large glass-topped filler, and gauze strainer. Needle valve to regulate flow of petrol. Lubricating oil carried in a separate tank. Petrol capacity, $1\frac{1}{2}$ gallons.
- Frame** - - - - Royal Enfield loop frame, dropped at back to give low saddle position; fitted with spring footboards and registered design spring forks.
- Mudguards** - - - Strong and wide, with front extension and side shields on rear guard.
- Tyres** - - - - Palmer Cord, 26 in. x 2 $\frac{1}{4}$ in.
- Handle-bar** - - - Royal Enfield new design T.T. handlebar.
- Brakes** - - - - Powerful inverted lever front rim brake; rear brake operated by foot pedal.
- Saddle** - - - - Brooks' B170, specially large and well-sprung.
- Tool Bags** - - - Two leather pannier bags, containing complete set of tools.
- Carrier** - - - - Made from weldless tubular steel and strongly attached.
- Stands** - - - - Two stands fitted (one for each wheel). Both fasten securely with spring clips.
- Finish** - - - - Enamelled in best black enamel; tank artistically panelled in two shades of green. Bright parts heavily plated.

Price

The 6 h.p. Royal Enfield Side-car Combination.

THERE is no more popular side-car combination to-day than the 6 h.p. Royal Enfield. Designed by motor cyclists for motor cyclists, it has been rightly called "the finest vehicle on three wheels."

This model is built specially for side-car work. Every detail of its design and construction has been perfected with that idea in view. It has a 6 h.p. twin-cylinder engine of exceptional power and flexibility, also the Enfield Patent Two-Speed Countershaft Gear, Chain Drive, the Patent Cush Drive Rear Hub, and an improved Spring Front Fork with side-by-side springs. The lubrication is semi-automatic, and a most reliable handle-starter is fitted.

The side-car chassis is the strongest yet evolved (see pages 16 and 17 for details). As the attachments on the Motor Cycle are built in and permanently brazed to the frame, nothing short of an accident will place the Royal Enfield Side-car out of running alignment with the motor cycle.

Particular attention has been paid to the side-car body, and the type shown on the following page is constructed throughout in our own coach-building factory. Overleaf will be found further particulars of this model, also illustrations of the Royal Enfield cane side-car body, which can be fitted without extra charge. Details of the mechanical features are described on pages 26 and 27.

N.B.—Read the testimonials on pages 28 and 29, which are just a few from the large sheaf of similar letters we have received.

Royal Enfield 6 h.p. Side-Car Combination, with Royal Enfield Patent Two-speed and Free Engine Gear. Model 180.

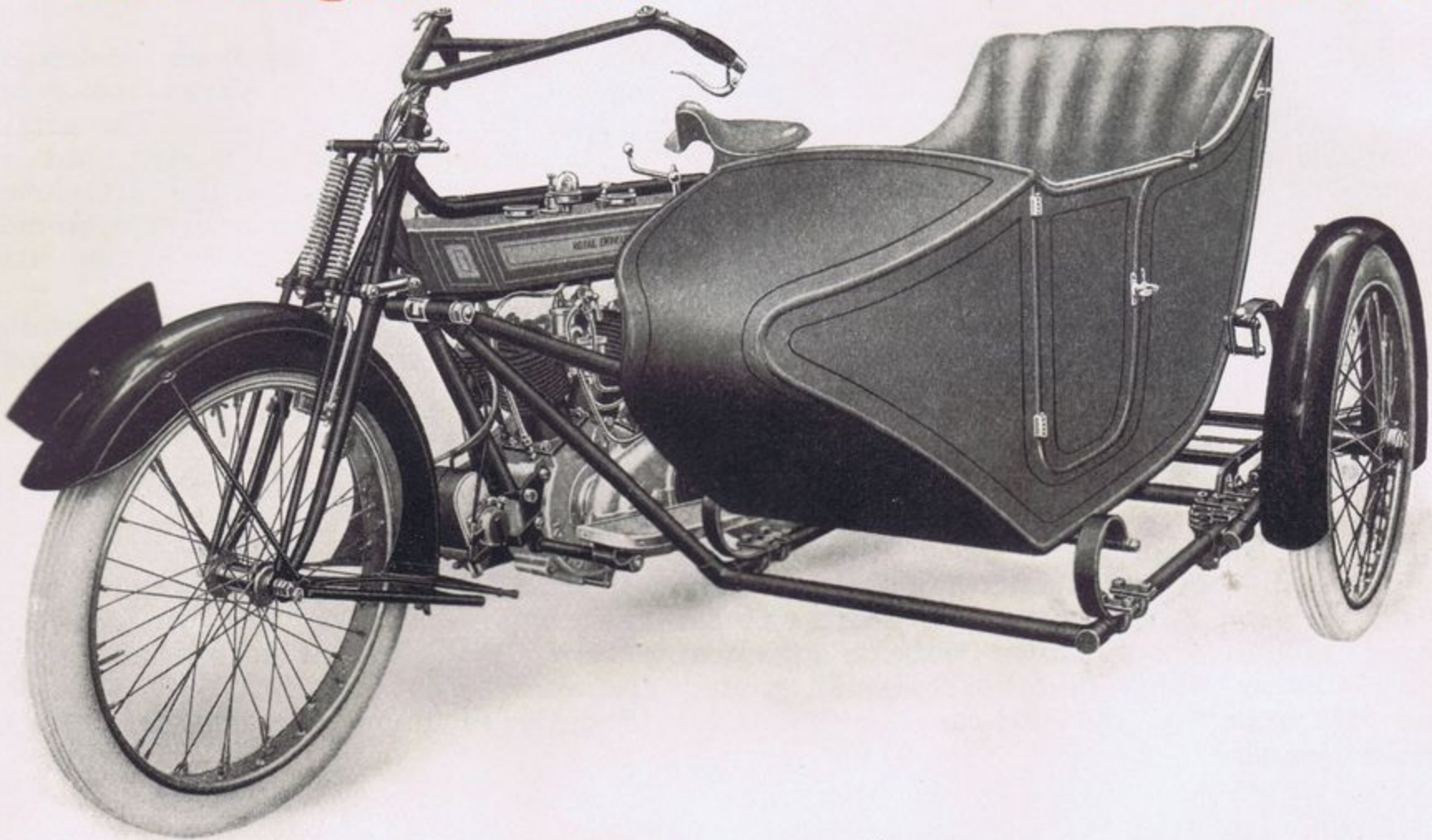

SPECIFICATION.

- Engine** - - - - Royal Enfield twin cylinder, bore and stroke 76 by 85 m/m ; mechanically operated valves, and simplified valve gearing.
- Two-Speed and Free Engine Gear.** Royal Enfield patent, expanding clutch type, handle starting.
- Transmission** - - Roller chains ; with Royal Enfield slipping clutch and patent Cush Drive Hub.
- Cush Drive Hub** - The Royal Enfield Patent Cush Drive Hub is fitted. (See page 20.)
- Ignition** - - - - Latest Bosch magneto, controlled from handlebar ; waterproof terminals.
- Carburetter** - - - - AMAC multiple jet.
- Lubrication** - - - - Automatic visible drip-feed and auxiliary hand pump.
- Tank** - - - - Two compartments ; petrol capacity, 2 gallons ; oil capacity, 3 pints.
- Frame** - - - - Royal Enfield design, plenty of ground clearance ; side-car attachments built into frame. Fitted with footboards and improved spring forks.
- Tyres** - - - - Palmer Cord "Cycle-car" Tyres, 650 by 65 m/m on all three wheels.
- Mudguards** - - - - Strong and wide, with extension to front, side shields, and front mud flap.
- Carrier** - - - - Made of specially strong steel tubing.
- Stands** - - - - Stands for front and rear wheels and side-car wheel fitted.
- Handlebar** - - - - Royal Enfield registered design ; concealed cables through handlebar.
- Brakes** - - - - Powerful inverted lever front rim brake ; rear brake operated by foot pedal.
- Saddle** - - - - "XL'ALL," large and comfortable pan seat.
- Toolbags** - - - - Two pannier bags in special steel shields, containing complete set of tools.
- Finish** - - - - Attractively enamelled in best black enamel ; bright parts heavily plated. Tank artistically panelled in green.
- Side-Car** - - - - Royal Enfield chassis, exceptionally strong and well sprung ; coach-built or cane body ; luggage grid fitted at rear. See following pages for complete description.

Price, Complete with coach-built side-car body and luggage grid (as illustrated above)

See following page for description of Cane Side-Car Body.

BARNSTORMERS.CO.NZ

The 6 h.p. Royal Enfield Side-car Combination— The Side-car Chassis—Cane Side-car Body, etc.

The side-car chassis of the 6 h.p. Royal Enfield Combination has been re-designed and greatly improved for 1914. The accompanying illustration clearly shows the details of this chassis, and the means by which it is coupled up to the motor cycle. The attachments to the motor cycle are not merely bolted on, as in most side-car models, but are actually built in as part of the frame itself. This method not only makes the attachment exceptionally strong and safe, but also ensures the side-car running in perfect alignment with the motor-cycle; in fact, nothing short of an accident or abnormal strain would make it do otherwise.

Throughout the construction of the side-car chassis the very best quality weldless steel tube is employed. The springing is most luxurious, the side-car body being carried on "C" springs, both at the back and front, as shown.

Special Chassis for Use Abroad.

It is of the utmost importance that a motor cycle and side-car for use abroad, where roads are rough, and obstacles frequent, should be built specially to suit the road conditions. To all 6 h.p. Royal Enfields intended for use abroad we fit a special Colonial side-car chassis, which gives exceptional ground clearance. The illustration on this page shows it excellently, the side-car being raised sufficiently to prevent it fouling even the largest of stones.

The 6 h.p. Royal Enfield, with Cane Side-car Body.

Although we supply the 6 h.p. Royal Enfield with our own make of coach-built body, as illustrated on the preceding page, we also fit the art cane body on the same chassis, as illustrated opposite. This is a particularly neat and well-constructed body, and is supplied at the same price as the coach-built type.

The Luggage Grid.

The Luggage Grid is also an entirely new design, and is now included as part of the standard equipment of the 6 h.p. Royal Enfield. It is strong enough to carry quite heavy luggage, and, being placed at the rear of the side-car body, the weight is evenly distributed between the two rear wheels, and therefore imposes no undue strain upon any part of the combination. There is ample clearance between the underside of the luggage grid and the ground, so there is no possibility of the grid fouling any road obstruction which the side-car itself would clear. An illustration of the luggage grid appears on page 18.

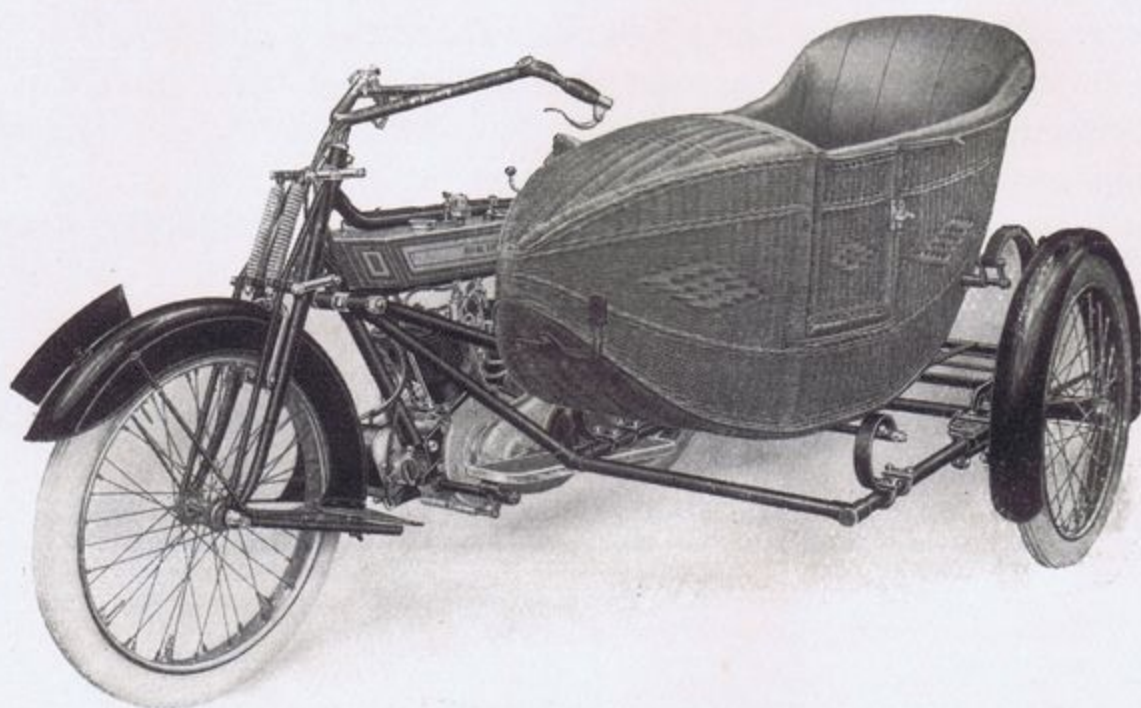

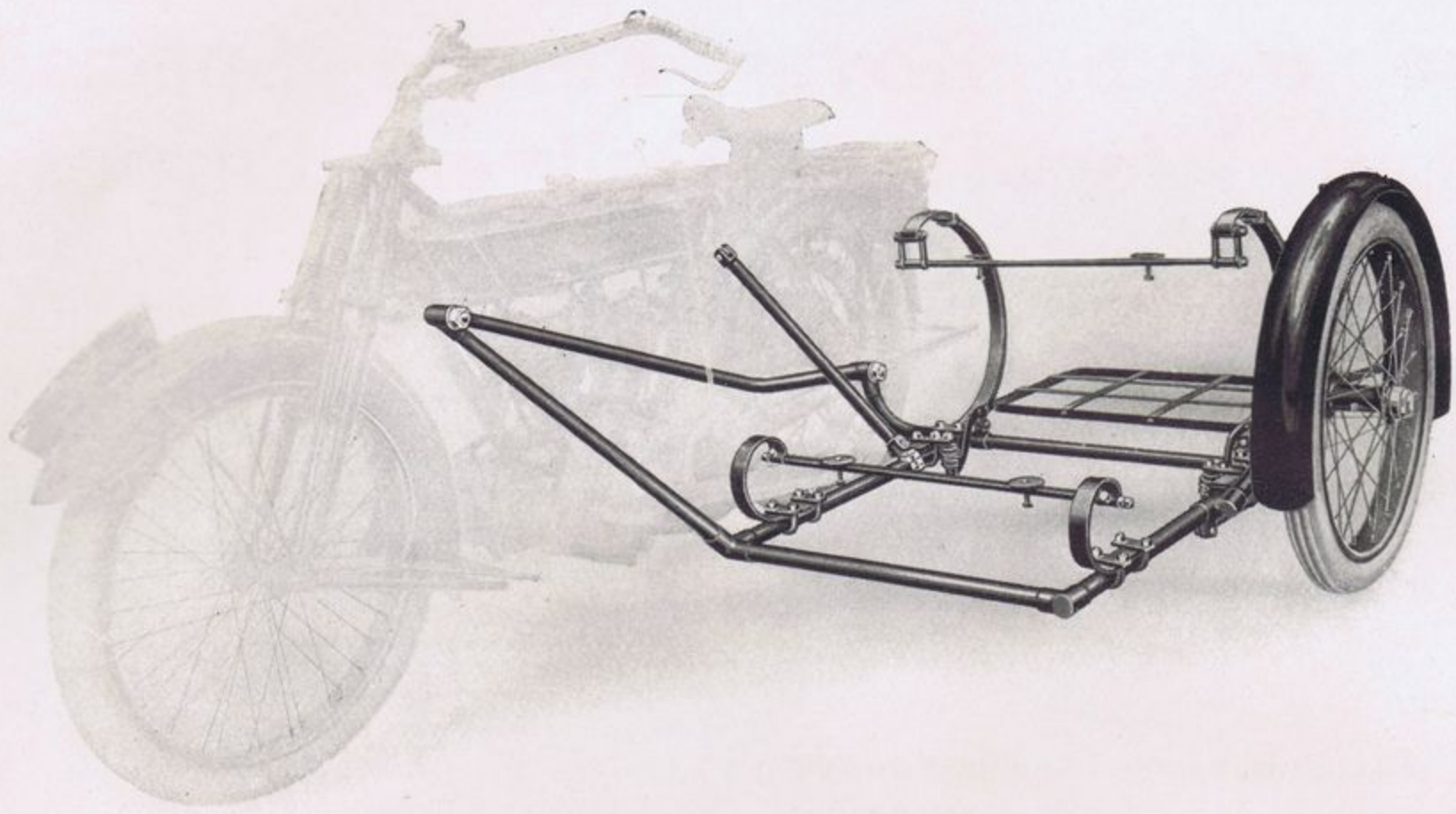

The 6 h.p. Royal Enfield Side-car Combination with the side-car body removed, showing in detail the Side-car Chassis and attachments.

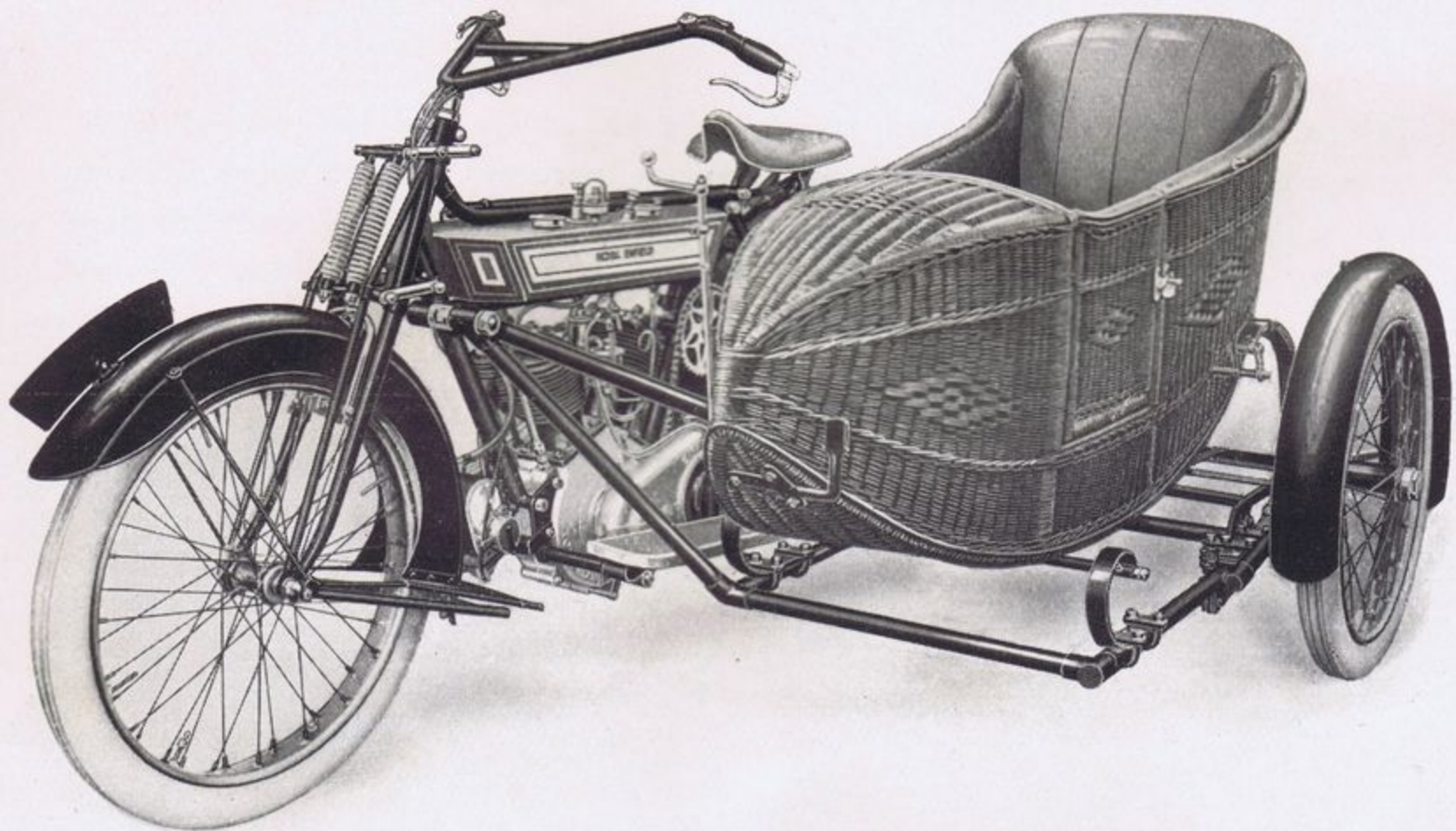

The 6 h.p. Royal Enfield Side-car Combination, showing the 1914 pattern art cane Side-car body. This is supplied, if desired, in lieu of the coach-built body illustrated on page 15, at the same price

The 6 h.p. Royal Enfield Specially Adapted for Trade Delivery Purposes.

We supply the 6 h.p. Royal Enfield fitted with our new side-car chassis and box carrier body, as illustrated on the opposite page. This makes an extremely efficient means of delivery, as the box is roomy, and the speed and power of the motor cycle makes it possible to effect delivery of goods more rapidly than by any other means.

The chassis is specially adapted to take the carrier body; the latter is strong and commodious, carefully made from well-seasoned wood by experienced coach-builders.

If desired, we can fit a special basket carrier body in place of the box. The basket body is very suitable for delivery purposes where a large number of parcels, which are bulky without being of great weight, need to be carried. For laundry collection and delivery, confectioners' goods, etc., the basket is probably more suitable than the box.

Taking into full consideration the large area which can be covered with a motor cycle, these special combinations for trade delivery purposes will do more work in a given time than a horse and van. There is no reasonable limit to the daily mileage possible with a motor cycle and side-car, because it can be worked, if necessary, every hour of the twenty-four. Moreover, the reliability of such a combination is one of its most notable features.

Running expenses vary with the locality and the class of goods carried, but making reasonable allowance for all possible items of upkeep, and also allowing a 10 per cent. annual depreciation—it will be found that 1½d. per mile more than covers the cost for an approximate annual mileage of 5,000 miles. There is no other light delivery vehicle which can compare with this for all-round cheapness and efficiency.

The 6 h.p. Motor Cycle.

We also illustrate on the opposite page one of our standard 6 h.p. motor cycles with the side-car detached, and photographed so as to show the valve side of the engine. The handle-starting arrangement is also clearly seen, together with those other mechanical details which are somewhat obscured by the position of the machine in the illustration on page 15.

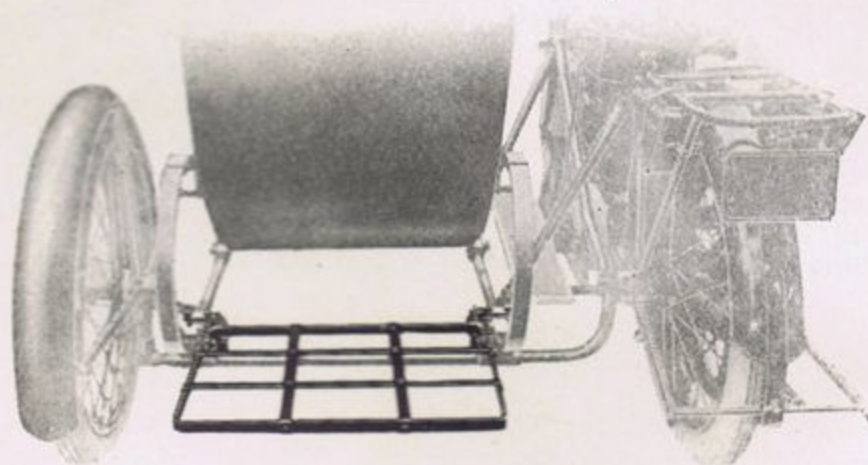

View of the 6 h.p. Royal Enfield Combination from the rear, showing the Luggage Grid in position.

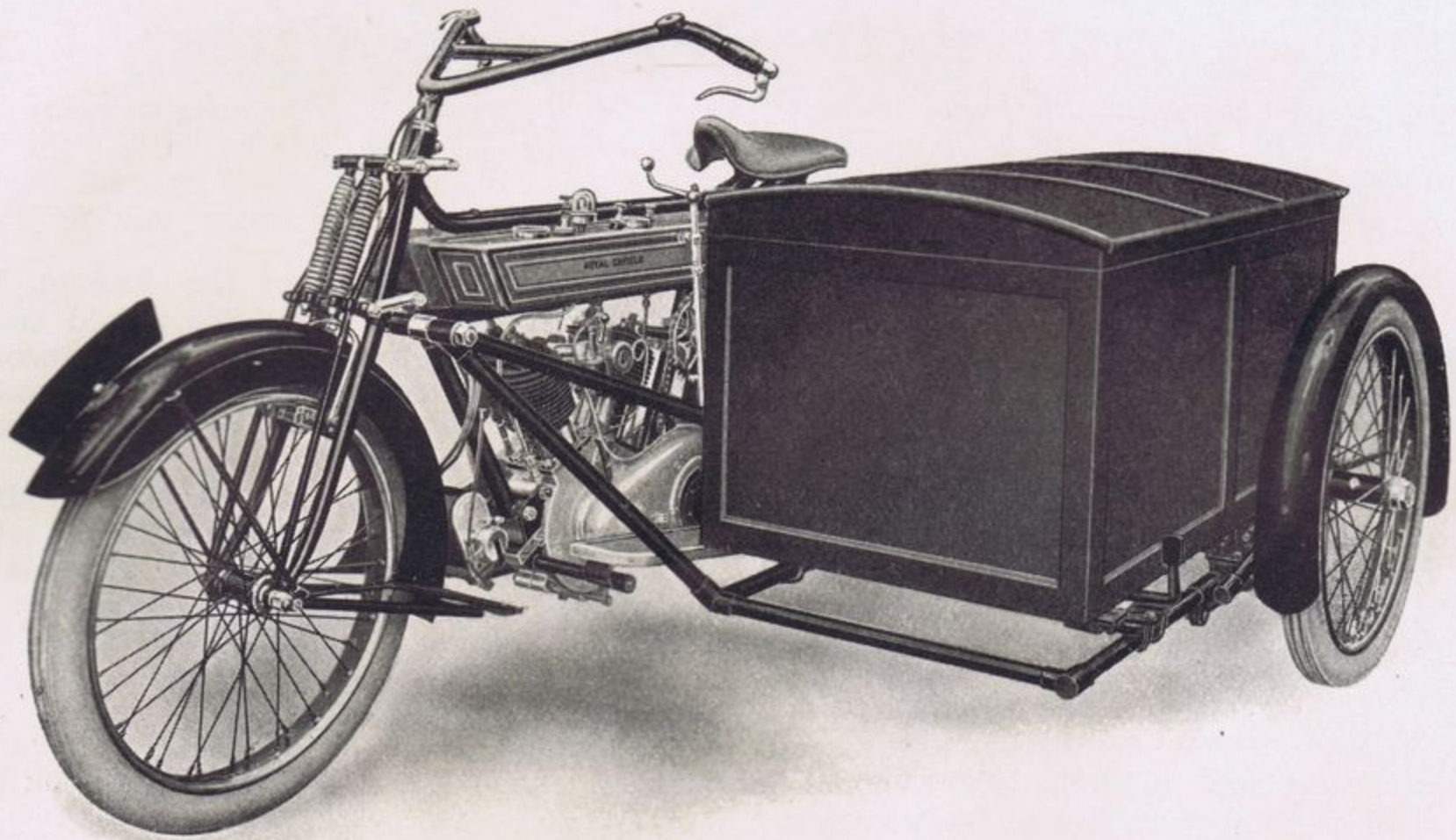

The 6 h.p. Royal Enfield, fitted with special Box Carrier Body for trade delivery purposes. Price,

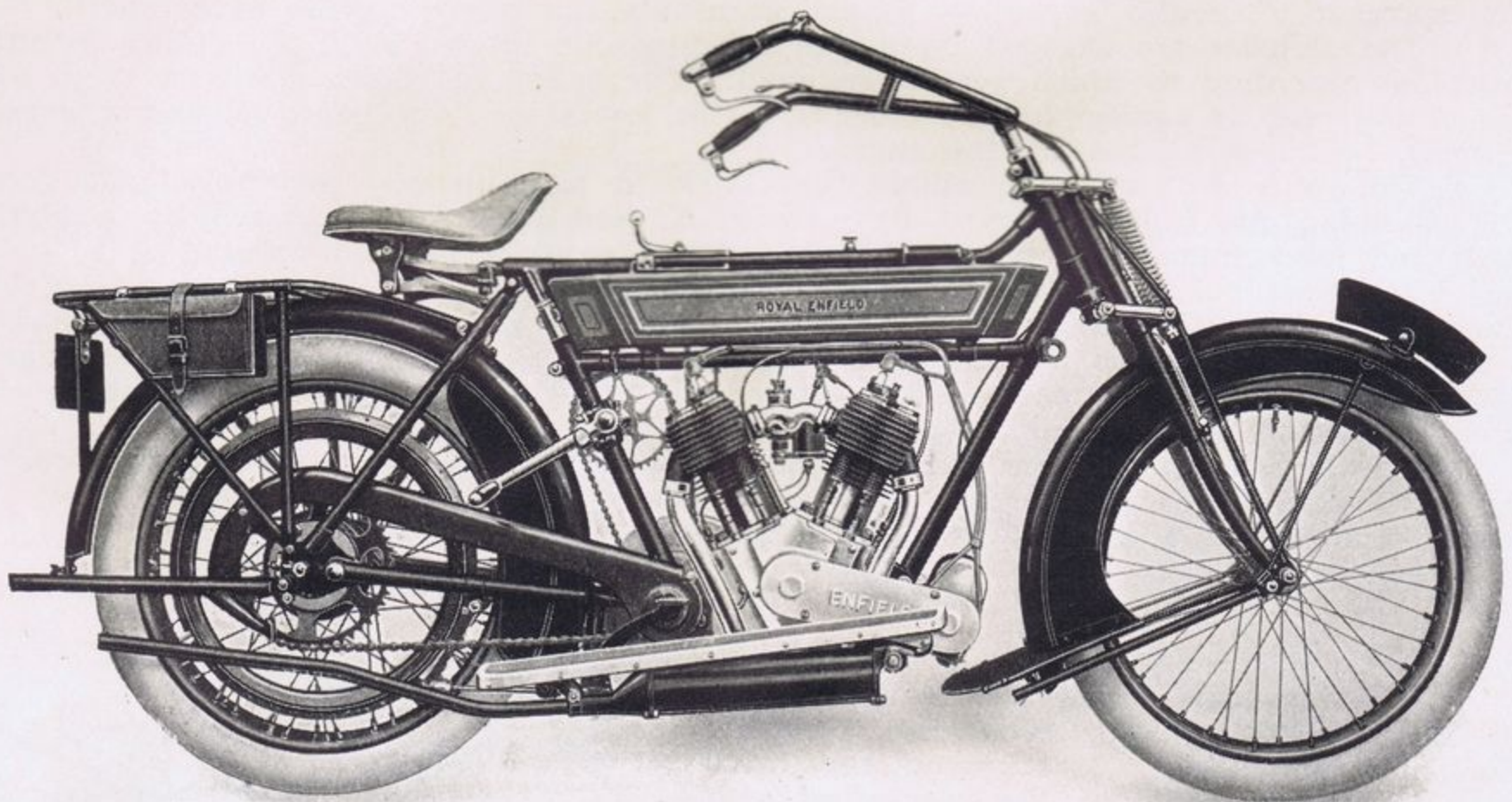

The 6 h.p. Royal Enfield, showing the valve side of the Engine, and the handle-starting arrangement. For complete specification, see page 15.

BARNSTORMERS.CO.NZ

The Royal Enfield Patent Two-speed and Free Engine Countershaft Gear—the Patent Cush Drive Hub—The Enfield Chain Transmission.

Two-speed and Free Engine Gear.

The very fact that no change has been made in the design of the Enfield Two-Speed Gear is proof that our customers find it perfectly satisfactory. We would further point out that many of the leading motor cycle manufacturers—both at home and abroad—are fitting our patent Two-Speed Gear to their models. It is now universally realised that of all variable gears for motor cycles the countershaft gear is the most satisfactory and of all countershaft gears the Royal Enfield has best stood the test of time.

Most important amongst the features of the Enfield Two-Speed Gear is the simple method of control and operation. One movement of a hand-operated lever brings either gear into engagement; thrust forward, the high gear is engaged, backwards towards the saddle engages the low gear, and mid-way between these two positions gives the free engine. The great point is that through both gears the drive is direct; with those types of gears in which it is necessary to run through a chain of wheels, friction is bound to be present, but in the Enfield Gear it is practically non-existent.

Though seldom required, adjustment of the Gear is very simple. Apart from this, the only attention it needs is occasional lubrication. The Royal Enfield Handbook deals fully with both adjustment and lubrication.

Explanation of Diagram.

The diagram on the opposite page shows the Enfield Two-Speed and Free Engine Gear as fitted to a 6 h.p. Model. It is substantially the same on our other models, except that one or two minor details are adapted to suit the differences in frame design and engine position.

It will be readily seen that either gear is brought into action by expanding the hardened steel bands *A* into one of the drums *B*, also of hardened steel, and to which the chain wheels *C* are fixed; the change in gear ratio being effected by different sized sprockets on the engine shaft. The expanding bands *A* are carried on internal drums *D*; these take the drive and are keyed to the shaft *E*, which runs on ball bearings. The sprocket *F* is also keyed to *E*, and transmits the power to the back wheel.

The clutches are engaged by a pair of cams cut in the block *G*, sliding in either direction, according to which gear is required. The action of sliding the cam is to force one of the pegs *H* against a split roller *I*. This forces open the band *A*, and it engages with *B*, which is rotated by the engine.

The roller *I* being split, allows the clutch to pick up very smoothly. The block *G*, containing the cam, is moved by a rack *K*, and pinion *J*, operated by a vertical shaft and lever from the top of the tank. Three pairs of cams, numbered 1, 2, 3, are cut in *G*, each being .005 inches higher than the one before it. Should any wear take place, it can be adjusted by engaging the next pair of cams, which is but the work of a few minutes. There is no thrust on the bearings when either in gear or free engine; thrust occurs only when the clutches are being engaged or released; then it is only momentary, and is taken up by a thrust bearing *L*.

On the 6 h.p. model the chains from the engine to the two-speed gear sprockets are now encased in an aluminium gear-box. This is light, but completely encases the chains, and makes a particularly neat fitment.

The Royal Enfield Patent Cush Drive Hub.

This ingenious patent Rear Hub fitted to all Royal Enfield motor cycles is a complete shock-absorbing device. It takes up the drive from the countershaft to the rear wheel with flexibility and smoothness, having a marked effect on the running of the machine, and minimising the wear of the rear tyre to a surprising degree. The accompanying illustration



Principal Constructional Features of the $2\frac{3}{4}$ h.p. Royal Enfield Model.

In open competition against the best machines of other makes, the $2\frac{3}{4}$ h.p. Royal Enfield has demonstrated again and again its immense power and speed; whilst no better proof of its reliability is wanting when we say that several owners of $2\frac{3}{4}$ h.p. Royal Enfields have ridden their machines for thousands of miles with a side-car attached.

Obviously, it is unfair to expect any motor cycle rated at only $2\frac{3}{4}$ h.p. to pull a side-car and passenger, even under the most favourable conditions, and we cannot too strongly deprecate such treatment. But the fact remains that Royal Enfield $2\frac{3}{4}$ h.p. models have done it, and without any apparent harm to the engine during thousands of miles of service.

The capacity of this engine is 343 c.c., the bore and stroke respectively 54 by 75 m/m. The valves are interchangeable; the inlet valves mechanically operated, and, being set outside the V area of the engine, are in the best position for cooling. The valve tappets are operated from a camshaft by long rocking levers, thus preventing side-thrust and tappet wear. On the right hand side will be noticed the bevel drive to the magneto.

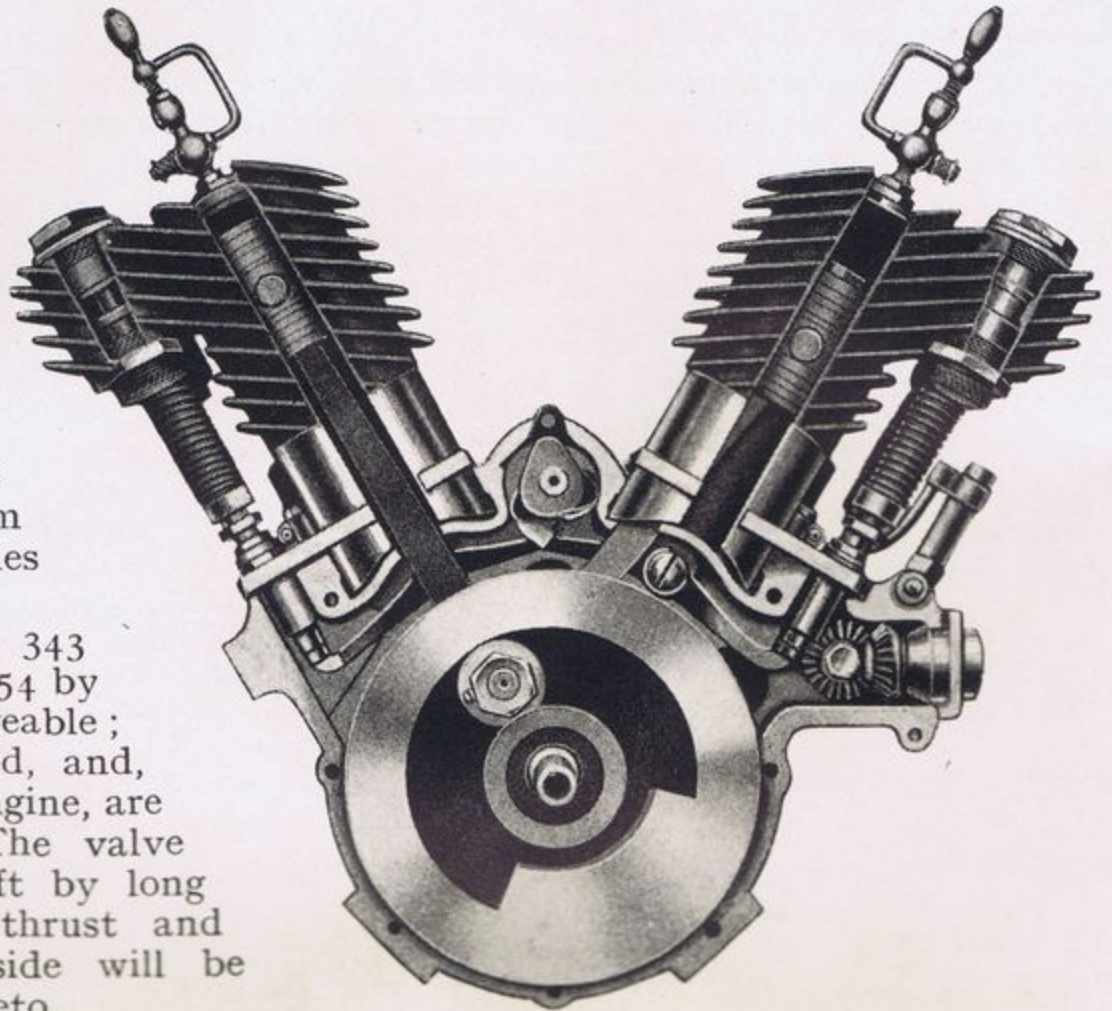

The 1914 "Kick-starter."

The "Kick-starting" lever is in a position conveniently placed for the right foot. By sharply kicking down the arm the engine is instantly started. The lever automatically springs back into position immediately the foot is lifted from it. The "Kick-starting" clutch operates direct on to the driving shaft.

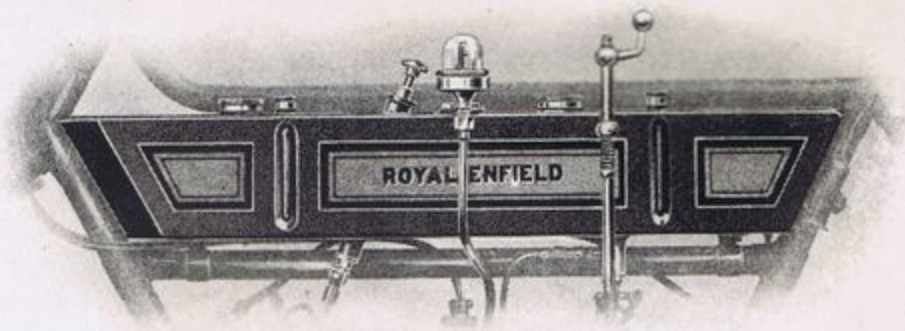

The $2\frac{3}{4}$ h.p. Royal Enfield Tank.

Spring Forks, Mudguards, etc.

The spring forks on the $2\frac{3}{4}$ h.p. machine are our own registered design, and possess immense strength and most effectual shock absorbing qualities. The $2\frac{3}{4}$ h.p. is a most comfortable model to ride, practically vibrationless.

It will be seen from the illustration on page 9 that both back and front mudguards are fitted with side shields, and the front guard is extended a considerable way over the wheel. Stands are fitted to both wheels, and the footboards are of ample length and width, and easily removable. Two oil cans, large tyre inflator, and complete set of tools in tool roll are provided with this and our other models free.



The 2 $\frac{3}{4}$ h.p. Two-speed and Free Engine Gear.

The two-speed and free engine countershaft gear fitted to the 2 $\frac{3}{4}$ h.p. Royal Enfield model is identical, so far as the principles of construction are concerned, with the gear fully described on pages 20 and 21. It has stood the test of many seasons' hard usage, and its reliability and efficiency under all conditions have been thoroughly proved. It follows the soundest engineering principles, experience having proved that the bottom bracket is the best position for the variable gear.

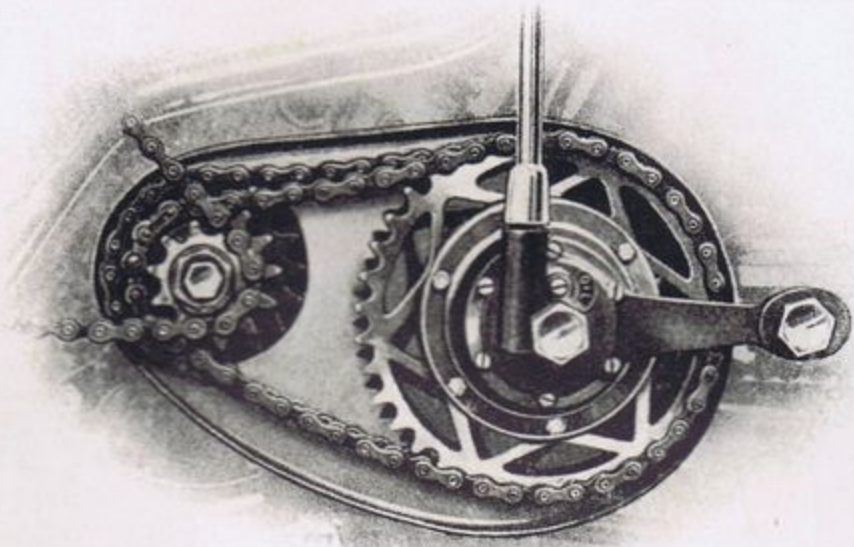

The Automatic Visible Drip-feed Lubrication.

This system of lubrication is a great advance on the hand pump. It works on very simple lines, and when once set needs no further adjustment. The partial vacuum occurring in the crank chamber is utilised to automatically draw the oil from the tank through a glass dome, which is removable for cleaning purposes. The rate of flow is always visible through this dome, and may be regulated by the thumb screw at the side. A ventilating valve does away with any back pressure. The accompanying illustration shows the system perfectly, and its simplicity is one of its greatest points. The flow should be adjusted to drip from 30 to 40 times per minute.

An auxiliary hand pump is fitted just in front of the drip-feed dome. It is advisable to occasionally use this hand pump, in addition to the drip-feed, when negotiating severe hills or riding long distances at high speed. A half pumpful of oil is quite enough at a time. After emptying the crankcase of accumulated oil always give a whole pumpful to replenish the supply.

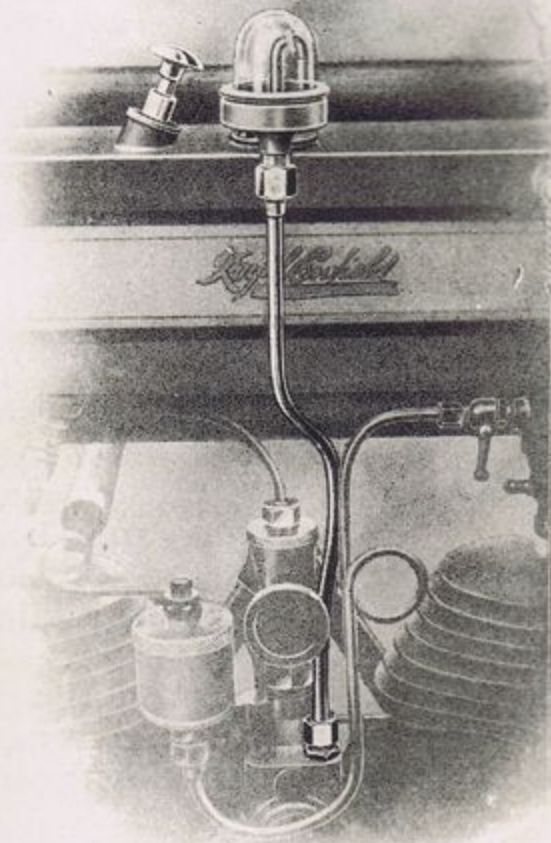

The Royal Enfield Handlebar.

The handlebar fitted to the 2 $\frac{3}{4}$ h.p. model is our own registered design, and is similar to the handlebar on our other models. The absence of unsightly cables and clips is a notable feature, the whole of the control wires being carried inside the bar as far as the head.

The extra air and throttle levers are fitted on the right hand side; the body of the control, as well as the lamp bracket, being an integral part of the handlebar. It is, therefore, impossible for them to become loose. The front rim brake and exhaust valve lifter are operated by inverted levers, one under each end of the handlebar; the front brake on the right hand side, and the exhaust valve lifter on the left hand.

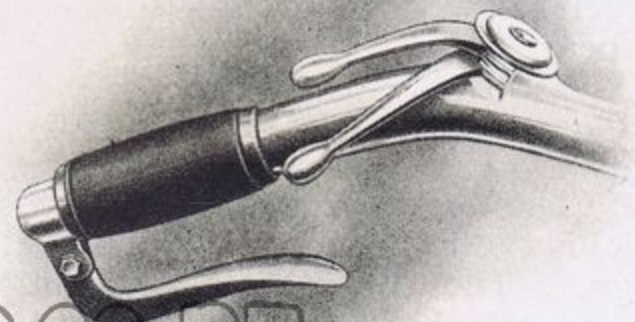
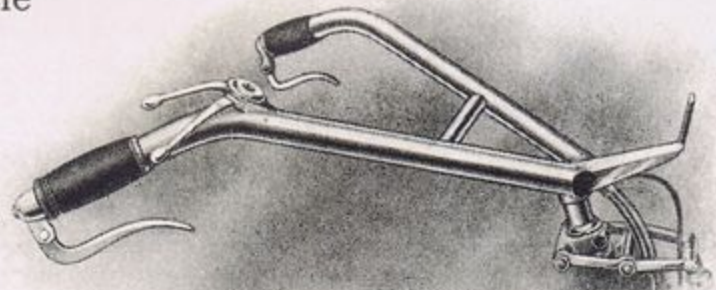

Principal Constructional Features of the 3 h.p. Royal Enfield Model.

(Full Specification is given on page 11.)

The 3 h.p. Twin Cylinder Engine.

There is little difference in the 3 h.p. engine from last year's model, excepting that we have made several minor improvements which we have thought desirable.

The dimensions of the 1914 standard engine are—bore 60 m/m, stroke 75 m/m, capacity 425 c.c., The simplified timing gear system is retained, one cam opening the inlet valves and a second cam the exhaust valves. Overhead inlet valves are fitted, and are housed in a dome directly over the exhaust valves. This arrangement permits of perfectly straight induction pipes, and consequently a direct and free ingress of gas. The rocker arm is cased in to exclude dust and dirt. We can supply no stronger proof of the efficiency of this 3 h.p. engine than to refer readers to pages 6 and 7, describing the wonderful performances at Brooklands during 1913 on 3 h.p. Royal Enfield models.

In every detail of this engine the usual Royal Enfield excellence is to be seen. The bearings are bushed crank pin and engine pin with phosphor bronze, and the fly-wheel shafts of ball bearings. The magneto is chain driven, and being fitted in front of the engine, it is in the best position possible.

The high efficiency of the engine is perfectly maintained by the improved mechanical forced-feed system of lubrication, fully described on the opposite page. By this means lubrication is carried out in a regular and mechanical method, and the engine is kept cool and able at all times to develop its utmost power.

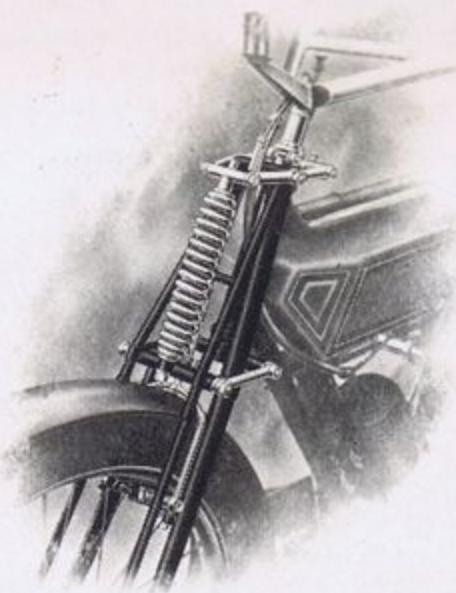
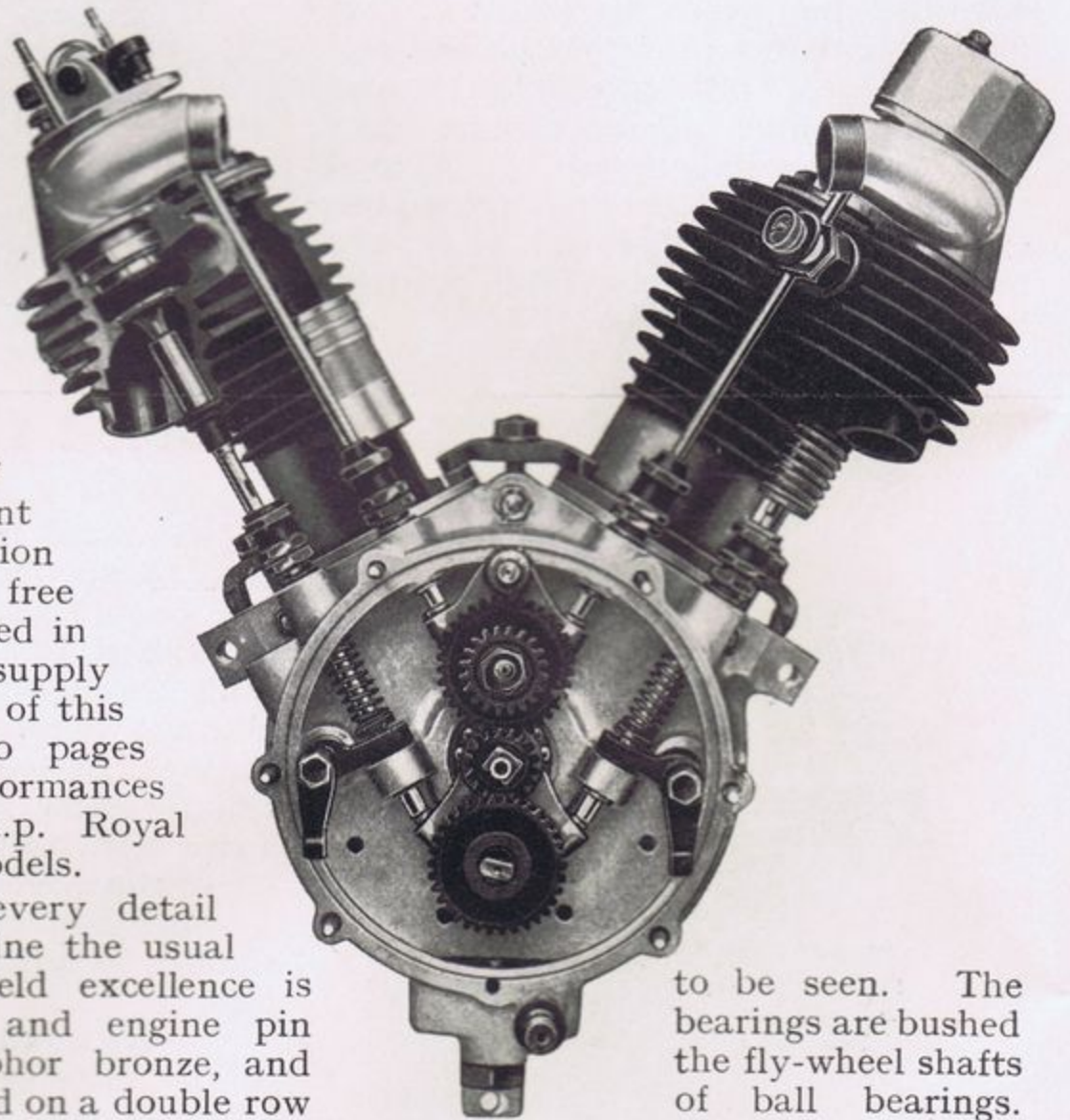

The 3 h.p. Spring Forks.

The spring front forks are the Royal Enfield registered design. They are made sufficiently wide to allow of ample clearance between the tyre and fork sides. The spring acts in tension when receiving a shock, and in compression when taking the recoil. The machine is at all times floating on the spring, and the vibration set up by road inequalities is effectively absorbed. The front hub is fitted with oil retaining cups and cones, and felt washers to exclude dust and dirt from the bearings.

The 3 h.p. Handlebar.

The standard handle bar fitted to this model is the well-known Royal Enfield registered design. The control bodies form an integral part of the bar, and the cables are carried



The New Royal Enfield "T.T." Handlebar.

inside as far as the head, so as to leave a perfectly "clean" bar. It is strengthened by a transverse strut, exactly as shown in the illustration of the 2 $\frac{3}{4}$ h.p. handlebar on the preceding page.

On the 3 h.p. T.T. Model we fit as standard a new type of semi-T.T. handlebar which we have specially designed for this machine. The illustration on the preceding page will convey an excellent idea of its design, and the disposition of the controls.

We can fit the new Royal Enfield patent spring handlebar to the 3 h.p. model for 21s. extra. This handlebar is fully dealt with on page 27.

The Petrol Tank.

As the diagram on this page clearly illustrates, the lubricating oil is carried in a separate tank at the back of the down tube. The top tube tank has no compartments, and carries the petrol only. The fittings are greatly simplified, and the tank is therefore stronger and free from any likelihood of leakage, whilst it is supported from the underside by our own improved and registered pattern supports. The needle valve on the top of the tank regulates the flow of petrol to the carburetter. The illustration shows the top of the tank and the fittings.

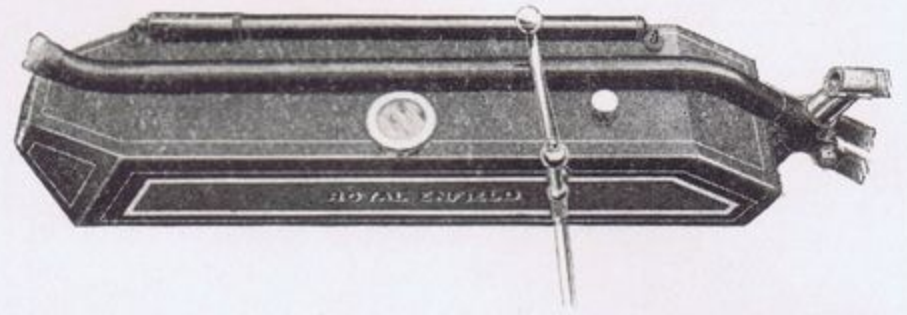

The illustration shows the top of the tank and the fittings.

The 1914 Kick-starter.

The kick-starter fitted to the 1914 model is on the left hand side of the machine, a most convenient position for utilising the full power and weight of the rider. It works direct to a clutch on the engine shaft, and after being forced down the lever automatically disengages itself and springs back into its original position. This is an improvement on the 1913 model, and has been thoroughly tried and tested before being adopted as a standard fitment for this season.

The 3 h.p. Lubricating System.

The mechanically forced lubrication fitted to the 3 h.p. model has been declared by experts to be the most perfect system yet evolved in motor cycle design. The oil is carried in a tank at the back of the down tube, and one of two pumps, fitted outside the timing gear case, inducts the oil to the engine; thence, after lubricating each cylinder, the second (expulsion) pump forces the oil back again into the tank. When the engine is running there is a continuous circulation of oil thoroughly and equally lubricating each cylinder.

The accompanying diagram shows the whole system. The supply of oil is regulated by a knurled top needle valve (B), and passes through a filter (C) along the suction pipe (E) to the induction pump (H). This pump discharges into the hollow end of the crankshaft (L), forcing the oil along

this shaft, through an aperture in the fly-wheel, into the crank pin bearing, and thence distributing it equally into both cylinders, so that each is perfectly and thoroughly lubricated. The oil then drips into the crank case sump, and any excess which has not passed through the engine shaft also finds its way through a release valve into this sump. From here (K) the oil is pumped by the expulsion pump (J) along the return pipe (D) back again to the tank. A filter in the crank case sump retains any residue from the oil before it is pumped back to the tank.

The flow of oil is regulated by the needle valve (B), which, under ordinary conditions, should be unscrewed about one turn. The supply may be varied by a simple adjustment, in half turns, of this valve.

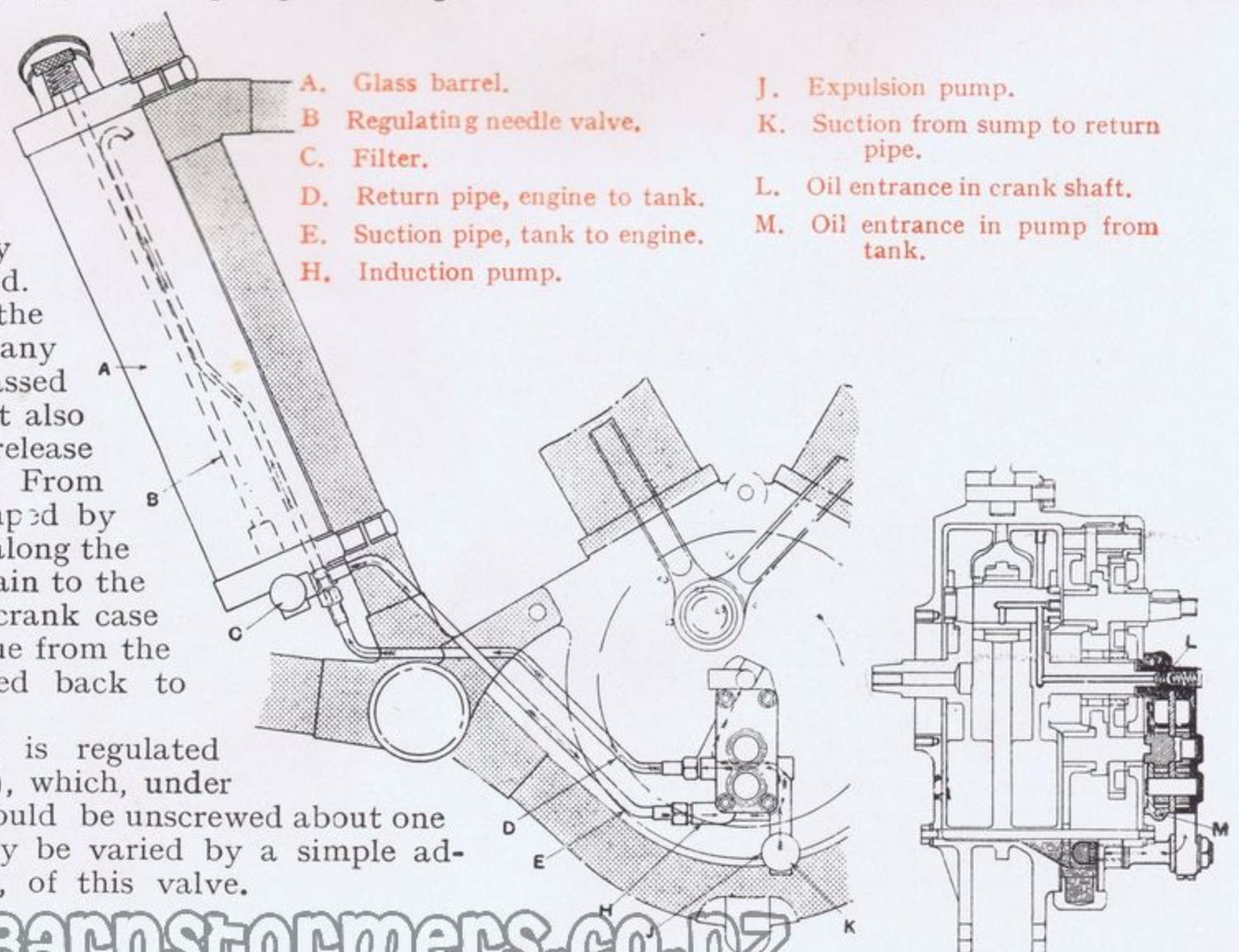

Principal Constructional Features of the 6 h.p. Royal Enfield Model.

(Full Specification is given on page 15. The Side-car, etc., is described on pages 16 & 18).

The twin-cylinder engine fitted to the 6 h.p. model is of substantial proportions, and is without doubt the most efficient and durable engine on the market. All excessive lightness of construction has been studiously avoided.

It has a bore and stroke of 76 by 85 m.m., and a capacity of 770 c.c. The patented valve gear is of simple design, one cam shaft only is used, thus eliminating a frequent source of noise. By an ingenious arrangement the four valves are operated by two cams, one operating the inlet valves, and the other the exhaust

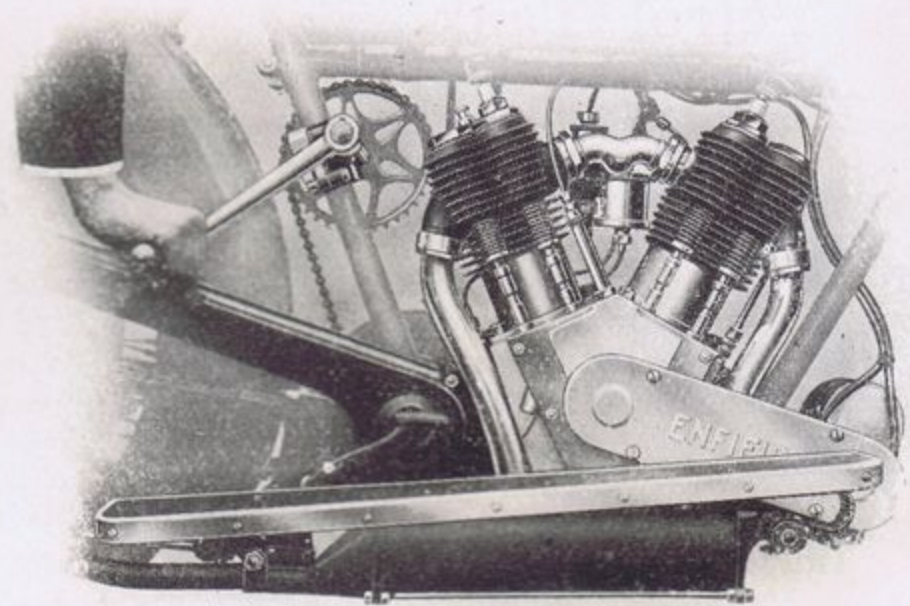

The 6 h.p. Royal Enfield Power Unit, showing the Handle-starter.

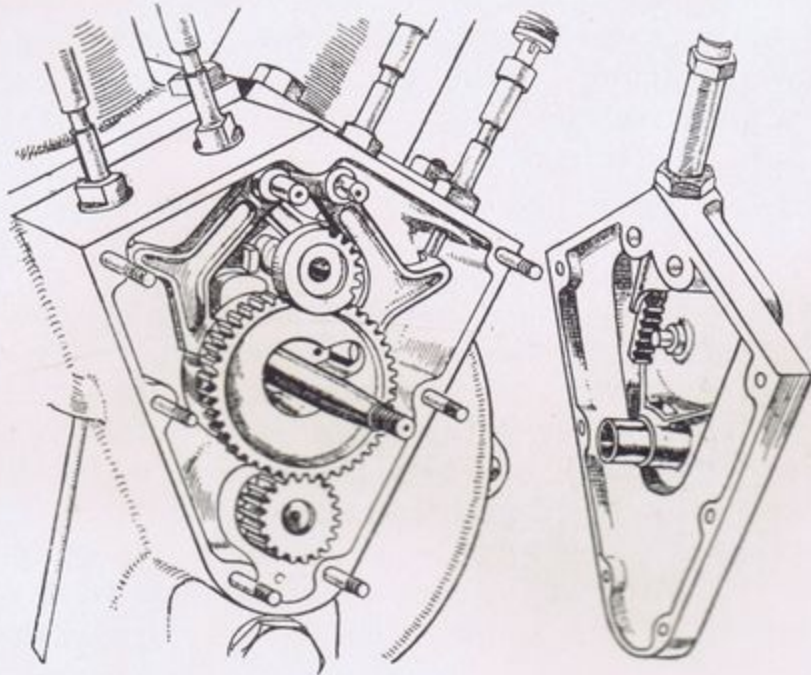

The simplified Valve Gearing of the 6 h.p. Engine.

valves, hardened steel levers being disposed between the cams and tappet rods.

The engine is started up by means of the handle shown in the accompanying illustration. This is geared to a clutch on the two-speed gear counter-shaft, and which in turn rotates the sprockets on the driving shaft of the engine. When the starting handle is out of use it is held in a neat spring clip.

The magneto is the latest Z.E.V. type waterproof Bosch. An AMAC multiple jet carburetter is fitted, and the carburetter and magneto controls are fitted to the handlebar as described on the opposite page.

The New System of Lubrication.

This system of lubrication is an additional means to those formerly employed on our 6 h.p. engine. The diagram on this page clearly shows the methods of ensuring proper lubrication at the big end of the connecting rod.

It consists of an oil box (A) cast on the side of the crank case. A passage (C) communicates between this oil box and the crank case through a non-return valve (B). When the piston is at the bottom of the down stroke, the pressure in the crank case forces oil through the valve (B) into the oil box (A).

When the piston is near the top of its stroke, a partial vacuum is formed in the crank case. Oil is thereby caused to pass up the pipe (D) through a recess under the bearing bush into a recess in the fly-wheel. From this recess the oil is thrown by centrifugal force, through passages in the fly-wheel, to the crank pin and the "big end bearing." The boss on the fly-wheel is formed into a rotary valve, to cover the aperture of the recess under the bearing bush when the piston is at the bottom of its stroke.

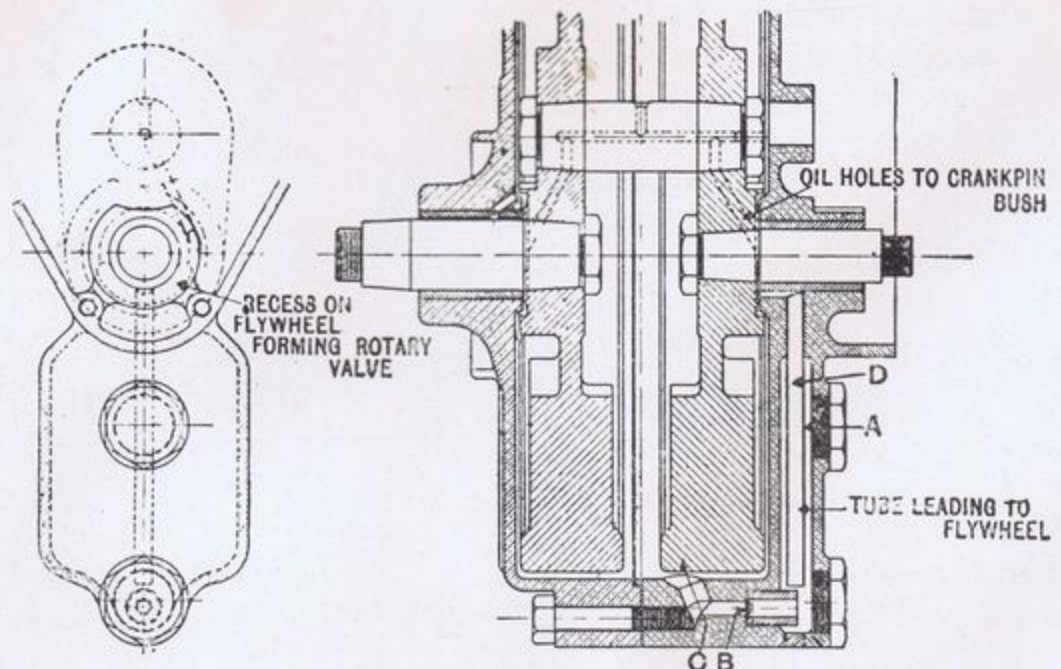

The Royal Enfield Handlebar.

The accompanying illustration shows the standard handlebar fitted to the 6 h.p. Royal Enfield model, this being our well-known registered design. It is strengthened with a transverse bar and the whole of the control wires are carried inside the handlebar as far as the head. No lamp bracket is fitted to this handlebar, as most owners of side-car machines usually fit a powerful acetylene lamp, which is carried on its own special bracket. We finish this handlebar by a special and lengthy process, and with a preparation which leaves a brilliant black finish, hard and permanent. This Royal Enfield black finish is a great improvement on the plated handlebar.

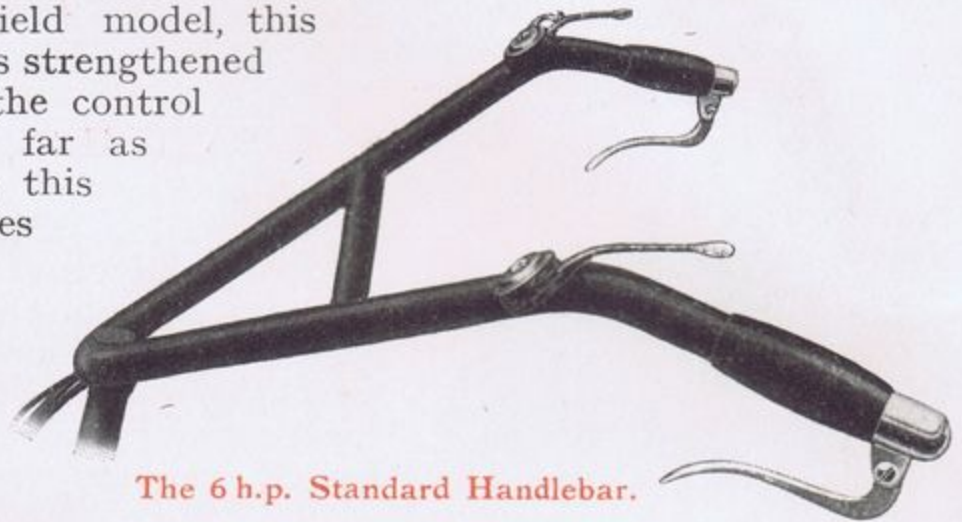

The 6 h.p. Standard Handlebar.

The Royal Enfield Spring Handlebar. (Patent No. 18558/13.)

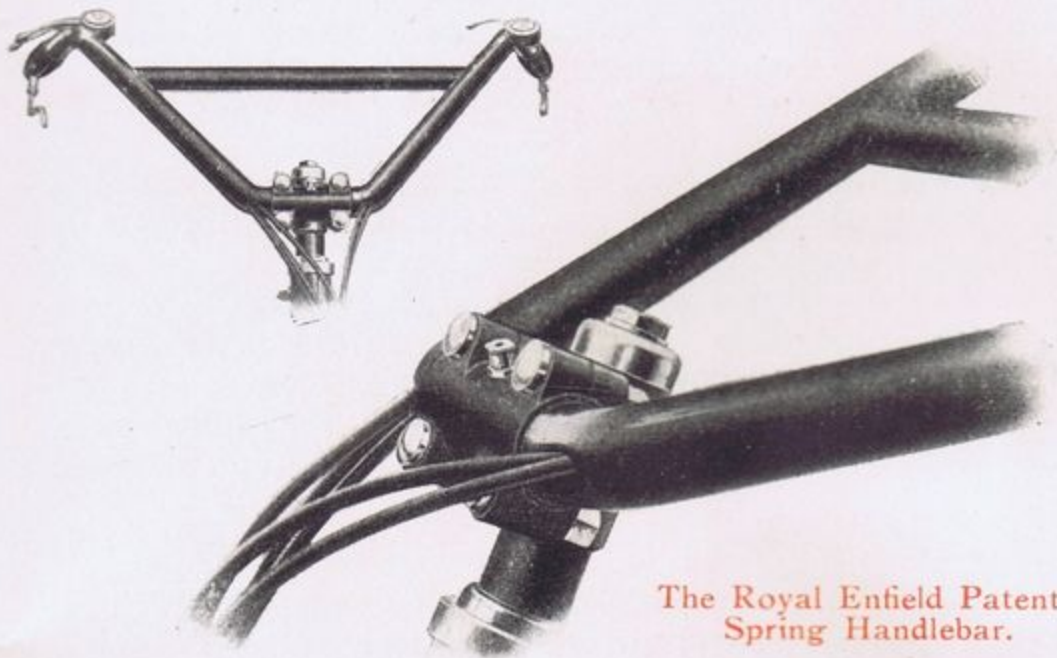

The Royal Enfield Patent Spring Handlebar.

One of the most important improvements introduced by us for the 1914 season is the patent spring handlebar, which we here illustrate. It will be seen that our well-known registered pattern handlebar (with the special black finish) is held in a two-piece lug, inside which is a strong but sensitive spring. This enables the handlebar to move vertically to the extent of several inches, and completely absorbs the shocks and jars arising from inequalities of the road. When actually travelling at speed the handlebar remains at a level position, although the head of the machine will be in frequent movement from contact with the road. The price of this Patent Spring Handlebar to our standard models is 21s. extra.

Spring Front Forks.

It will be noticed that we now fit to the 6 h.p. Royal Enfield side-car combination a front fork with two side-by-side springs. We have found from experience that for this model it is a great improvement over the single spring front fork hitherto employed. Every part is made from specially selected material, as we fully realise the utmost importance of reliable front forks in the construction of a motor cycle.

The 6 h.p. Tank.

We illustrate this tank in two positions—one giving a side view, and the other showing a plan of the top of the tank and the fittings. This tank has a capacity of two gallons petrol and three pints of oil. The drip-feed lubrication fitted (see description on page 23) is a great advance on the hand pump. The rate of flow is regulated by the thumb-screw, and a ventilating valve does away with any back pressure. For all ordinary running purposes the flow should be regulated to drip 30-40 times per minute. A hand pump for supplementary use is also fitted.

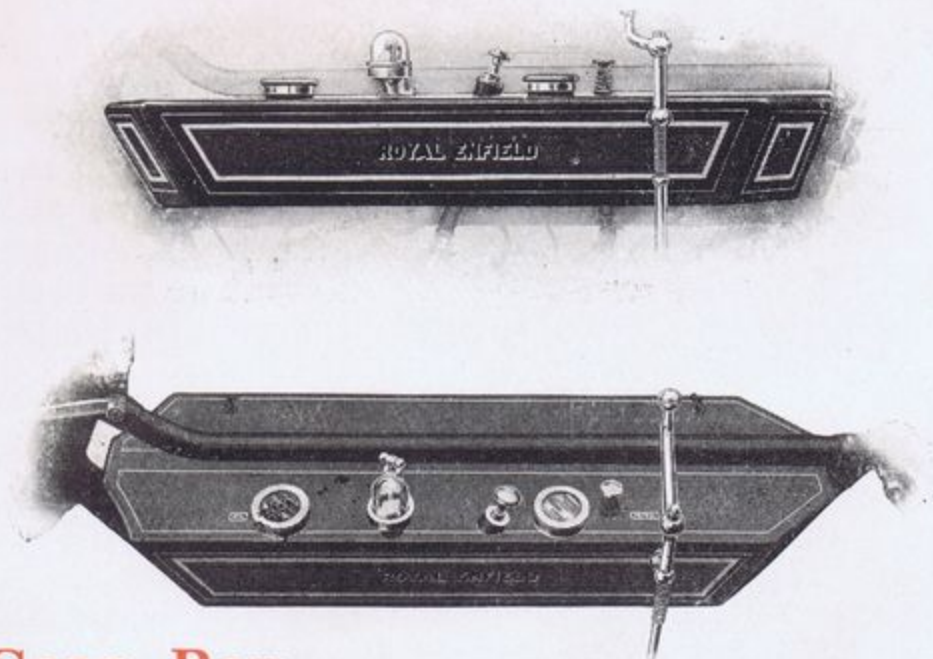

The Two-speed Gear and Gear Box.

Like all the Royal Enfield models, the 6 h.p. side-car combination is fitted with the Enfield patent two-speed gear, as illustrated and completely described on pages 20 and 21. The chains from the engine shaft sprockets to the countershaft are now encased in a cast aluminium gear-box, a big improvement on this model.

What Royal Enfield Owners say:

being just a few Testimonials taken indiscriminately from the very large number we have received. Reprinted by special permission of the writers.



G. J. EASTBURN, ESQ., A.I.C., HELENSBURGH.

"This photograph shows my 2½ h.p. Royal Enfield Motor Cycle in full touring trim. You will see I have fitted to the foot-board a small wooden box for carrying spares on long Continental journeys, and strapped to this box I carry extra tins of oil and petrol. I think you will agree that this is a considerable load for a light-weight (I weigh exactly eleven stones myself), but, after covering 5,614 miles, it is no exaggeration to say that my Royal Enfield is running even better than it did on the day I bought it."



S. F. WATSON, ESQ., IPSWICH (The original letter was penned to "The Motor Cycle").

"My mount is a 3 h.p. two-speed Enfield, and I have been about 2,500 miles, mostly on the worst roads that it is possible to find in Great Britain, namely, those of East Anglia, and have never yet had a serious involuntary stop whilst travelling. My only trouble has been a sparking plug, which gave out after seventy miles."



S. G. JAMES, ESQ., SANDWICH.

"I have just completed 4,600 miles on my 6 h.p. Royal Enfield Side-car Combination, and it is running better than ever. The Chain Drive is perfect, and I am unable to detect the slightest snatch. It is a most useful combination to anyone who plays golf, as scarcely any vibration is felt by the driver."



R. HOLLAND, ESQ., RAWTENSTALL.

"I have now run my 6 h.p. Royal Enfield Side-car Combination 9,000 miles, and I believe it is to-day as good as when I bought it. I have had no trouble whatever, its running during the second year being as good and as powerful as during the first year. Mrs. Holland weighs 14 stone 7 lbs., and I scale 16 stone 9 lbs., so that we are in the heavy-weight class, but the machine has been thoroughly reliable, even with over 31 stone up."



W. PRIESTLEY, ESQ., BRADFORD.

"I wrote to you in January last to express my appreciation of my 1912 6 h.p. Royal Enfield Side-car Combination, which during the 6,000 miles I rode it never caused me a moment's trouble. In March last I bought one of your 1913 6 h.p. models, and have had exactly the same experience, over a similar distance. The machine has always behaved splendidly under all conditions, notwithstanding that I invariably carry two passengers, my wife and daughter. I recently secured first place in the Reliability Trial for the E. S. Myers' Cup and Gold Medal, and which were awarded to me."

What Royal Enfield Owners say:

being just a few Testimonials taken indiscriminately from the very large number we have received. Reprinted by special permission of the writers.

R. WILKES, ESQ., SHREWSBURY.

"Having given my 3 h.p. Royal Enfield a most severe testing round Shropshire and North Wales, invariably with a passenger on the carrier, I have found it to be an absolutely 'no trouble' machine. Your mechanical lubrication as fitted to this model is splendid, also the Enfield Two-speed Gear and the Chain Drive. During some 6,000 miles on this machine I have never had to replace anything, the original chains and tyres still being in use, and I might add that it is the fastest motor cycle I have ever ridden."

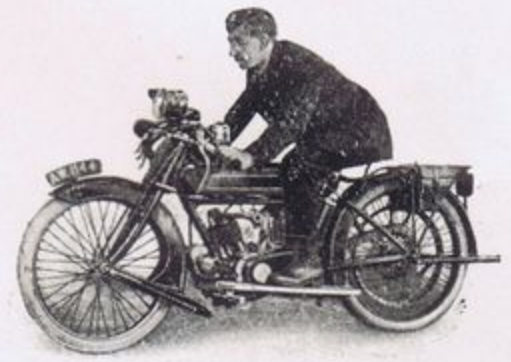

J. HART-SMITH, ESQ., SUTTON.

"Doubtless many motor cyclists would like to know what the 3 h.p. Royal Enfield with a Side-car can do on the road. My own machine is an absolutely standard pattern, with a capacity of 425 c.c. I have driven up Handcross and Reigate Hills with an adult passenger seated in the side-car in the normal way. As regards the running and the pleasure one feels when driving solo, I can quite confirm everything stated in the issue of *The Motor Cycle* of October 30th, 1913."

(We do not recommend the 3 h.p. model for use with a side-car, but we reproduce Mr. Hart-Smith's letter to show that it is quite capable of taking the extra load on occasions.)



WALTER BASELEY, ESQ., ALVECHURCH.

"For three years I used a well-known 3½ h.p. belt-driven machine, with very good results, especially if weather conditions were favourable, but I wished for something a little better. The Royal Enfield 6 h.p. side-car combination has always been my ideal, and in choosing it as my new machine I feel confident that I now possess the very best side-car combination on the road. It is powerful, reliable and comfortable to ride, and exceeds all my expectations. Moreover, in addition to the side-car passenger, I often carry a third person mounted on the back carrier of the machine."



W. H. SMITH, ESQ., LINCOLN.

"I have much pleasure to send you a photograph of my wife, daughter and self on board our 6 h.p. Royal Enfield Side-car Combination. We have done nearly 2,000 miles so far, and have nothing but praise for it. The machine keeps in tune without my having to constantly adjust it, whilst I consider the side-car chassis is one of the best designed parts of the whole outfit."



JOHN R. ASHWORTH, ESQ., RAWTENSTALL.

Written December, 1912: "I have travelled over 5,000 miles on my 6 h.p. Royal Enfield Side-car Combination, including tours in Devon, Cornwall, North Wales, and the Lake District, without the least trouble. My petrol consumption averages 75 to 80 miles per gallon, and the two-speed Gear and Chain Drive are excellent."

Written December, 1913: "I feel I cannot allow the year to close without giving you my experience with your 1913 6 h.p. Side-car Combination. I have covered over 6,000 miles during the season, and, beyond tyres, my expenses have been practically nil."





MISS E. WILKES, of Shrewsbury, and her 6 h.p. Royal Enfield.



MR. W. H. EGGINTON, of Birmingham, one of the most successful competition riders in the Midlands.

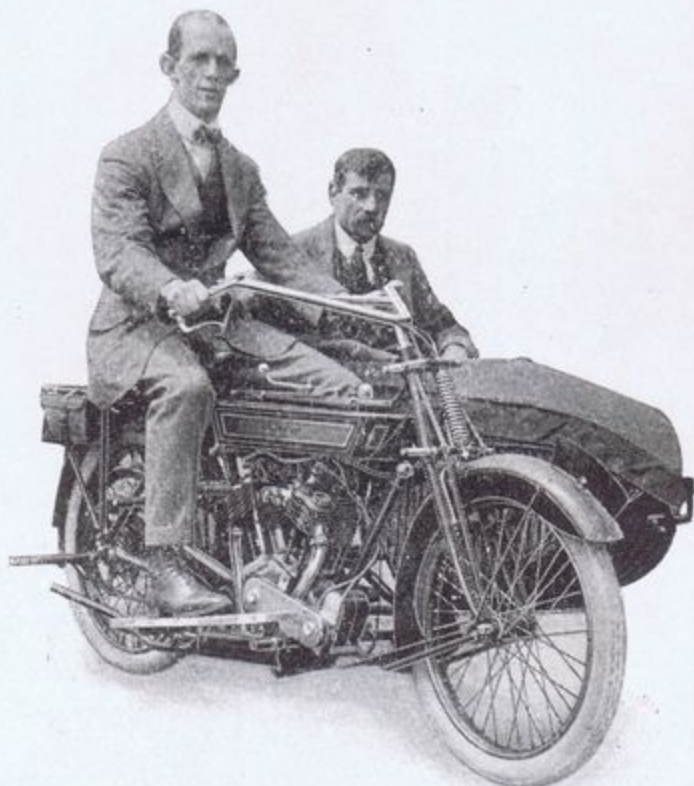

MR. O. J. PRILLEWITZ, the winner of the 200-mile Cape Peninsula Reliability Trial.

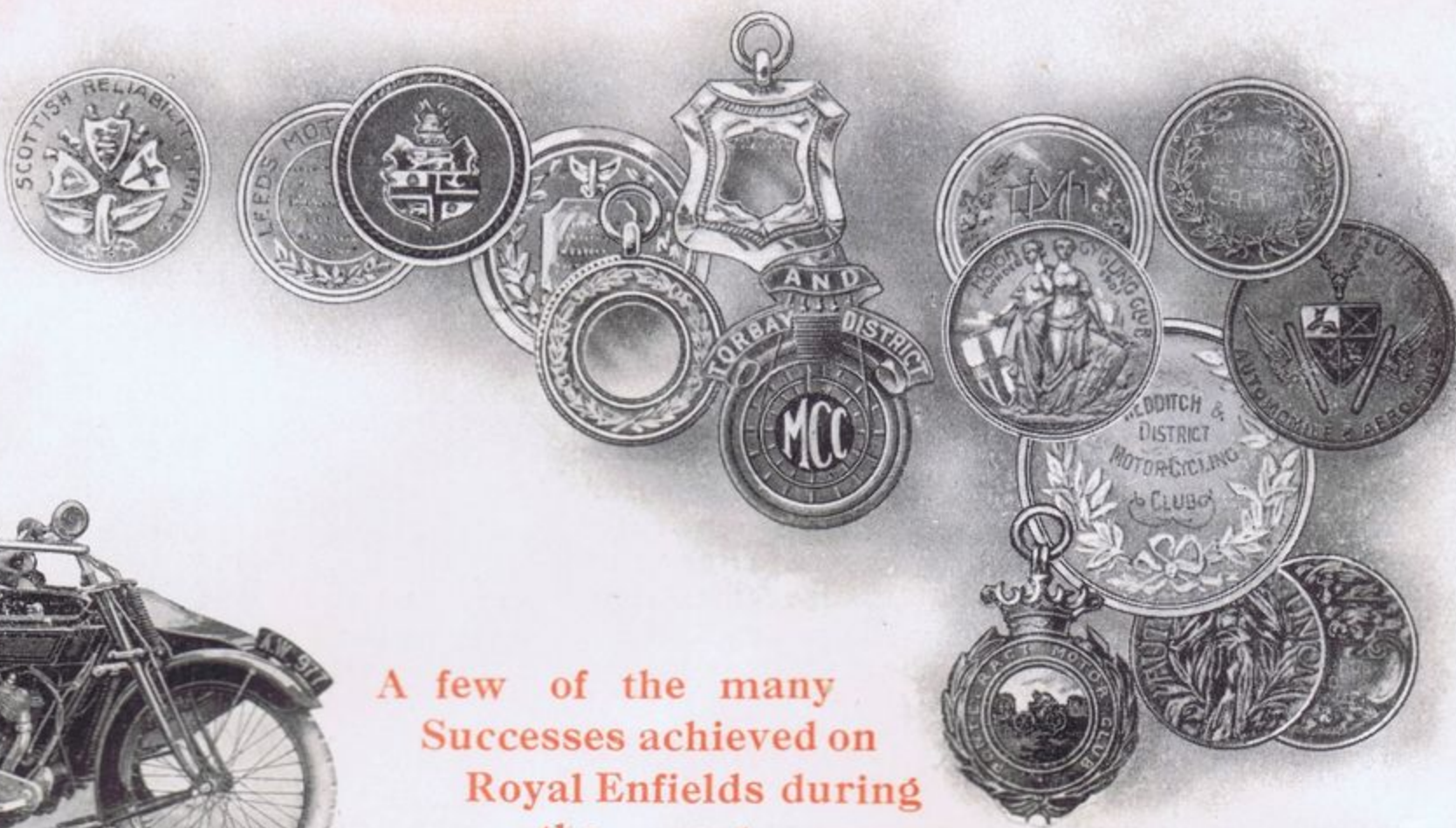

**A few of the many
Successes achieved on
Royal Enfields during
the past season.**

Jan. 25th. THE FIRST INDIAN TOURIST TROPHY RACE (First prize, £100, presented by the Maharaja of Tikari). First—2 $\frac{3}{4}$ h.p. Royal Enfield.

March 22nd. M.C.C. LONDON—LAND'S END AND BACK. One Gold Medal and two Silver Medals awarded 6h.p. Royal Enfield Side-car Combinations.

April 3rd. BLOEMFONTEIN HILL CLIMB. First—2 $\frac{3}{4}$ h.p. Royal Enfield.

April 12th. BIRMINGHAM M.C.C. OPEN RELIABILITY TRIAL. Two Gold Medals and one Bronze Medal awarded 6h.p. Royal Enfield Side-car Combinations.

April 20th. SOUTH BIRMINGHAM M.C.C. RELIABILITY TRIAL. Silver Cup for best performance awarded 6h.p. Royal Enfield Side-car Combination.

May 1st. MID-BUCKS M.C.C. HILL CLIMB (CLASS I) (Up to 350c.c.). First prize awarded 2 $\frac{3}{4}$ h.p. Royal Enfield.

May 12th. HAMPSHIRE M.C.U. ANNUAL RELIABILITY TRIAL. Poole Challenge Cup won by Bournemouth and District M.C.C. Team. Out of six riders in team five were mounted on Royal Enfields.

May 10th & 12th. M.C.C. LONDON—EDINBURGH AND BACK. Three Gold Medals awarded 6h.p. Royal Enfield Side-car Combinations (both journeys).

May 28th. CORK AND DISTRICT M.C. HILL CLIMB AT GRANGE HILL. All Comers' Class, 6h.p. Enfield first. Passenger machines, 6h.p. Enfield Side-car Combination first.

May 31st. SOUTH BIRMINGHAM HILL CLIMB (CLASS V.) 6h.p. Royal Enfield, fastest time, second on Formula, and Silver Medal.

June 21st. DENTON M.C. RELIABILITY TRIAL (SOLO CLASS). 2 $\frac{3}{4}$ h.p. Royal Enfield First.

June 21st. SOUTH BIRMINGHAM RELIABILITY TRIAL. New Hudson Cup won on 6h.p. Royal Enfield, also Bronze Medal.



**A few of the many
Successes achieved on
Royal Enfields during
the past season.**



MRS. M. RILEY, of Birmingham—one of the foremost lady riders of to-day—and her 6 h.p. Royal Enfield Side-car Combination.

June 28th. SVENSKA (SWEDEN) M.K. RELIABILITY TRIAL. First—2 $\frac{3}{4}$ h.p. Royal Enfield.

July 26th. CARDIFF M.C. BEVAN TROPHY RELIABILITY TRIAL. First prize (Bevan Trophy) won on 3h.p. Royal Enfield.

Aug. 4th. CAPE PENINSULA (South Africa) RELIABILITY TRIAL. First—6h.p. Royal Enfield Side-car Combination.

Aug. 4th. CORK AND DISTRICT M.C.C. RELIABILITY TRIAL. Gold Medal and special prize for best performance won by 6h.p. Royal Enfield and Side-car.

Sept. 14th. BIRMINGHAM M.C.C. CAPTAINS' TRIAL (12 HOURS' RIDE). First and Second prizes won on 6h.p. Royal Enfields and Side-cars.

Sept. 17th. O.F.S. AUTOMOBILE CLUB FIRST RACE MEETING (Long race, 16 $\frac{1}{4}$ miles). First—2 $\frac{3}{4}$ h.p. Royal Enfield.

Sept. 20th. BIRMINGHAM M.C.C. OPEN TRIAL. CARLISLE AND BACK. L.M.C. Watch and Gold Medal won by 6h.p. Royal Enfield and Side-car.

Oct. 6th. CAPE PENINSULA (South Africa) 200 MILE RELIABILITY TRIAL. First—6h.p. Royal Enfield Side-car Combination.

Oct. 26th. SOUTH BIRMINGHAM M.C. RELIABILITY TRIAL. L.M.C. Watch awarded to 6h.p. Royal Enfield Side-car Combination.

CANBERRA MOTOR CYCLE CLUB (Australia). 10 Mile Road Race. Entry of all the best makes. First—3h.p. Royal Enfield. Speed: 54.55 m.p.h. Australian Record.

Dec. 26th & 27th. BRISTOL M.C.C. BRISTOL—LAND'S END—BRISTOL RELIABILITY TRIAL.

48 entrants, but only one Gold Medal awarded, and that to a 6h.p. Royal Enfield Side-car Combination, also the Silver Cup for best individual performance to driver of same machine. One of the worst trials ever experienced—only six of the competitors finished.

Dec. 26th & 27th. LONDON—EXETER—LONDON. M.C.C. ANNUAL RUN.

Three Gold and two Silver Medals won on Royal Enfields.

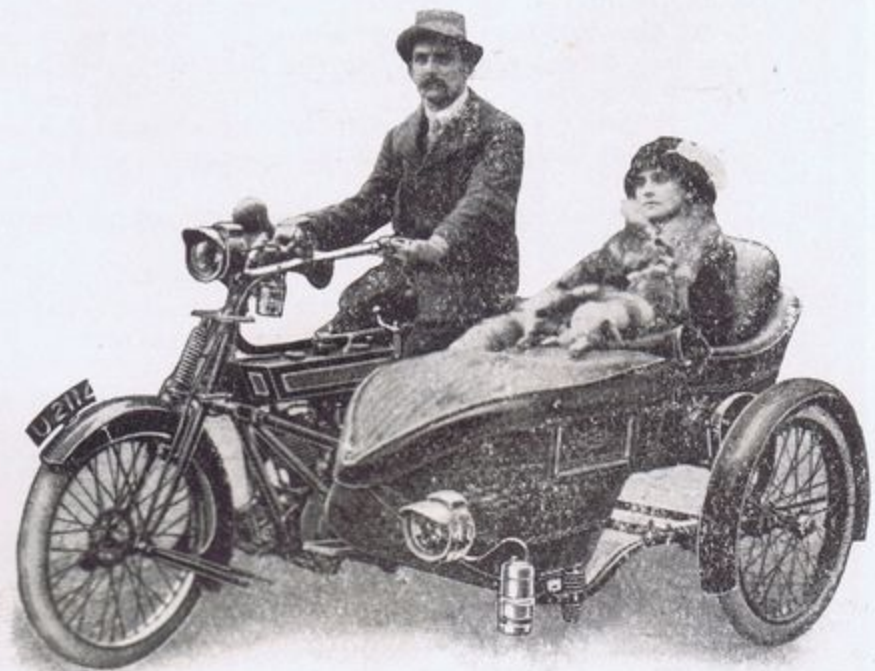

MR. C. P. FINN, of Wakefield, who has successfully ridden Royal Enfields for many years.

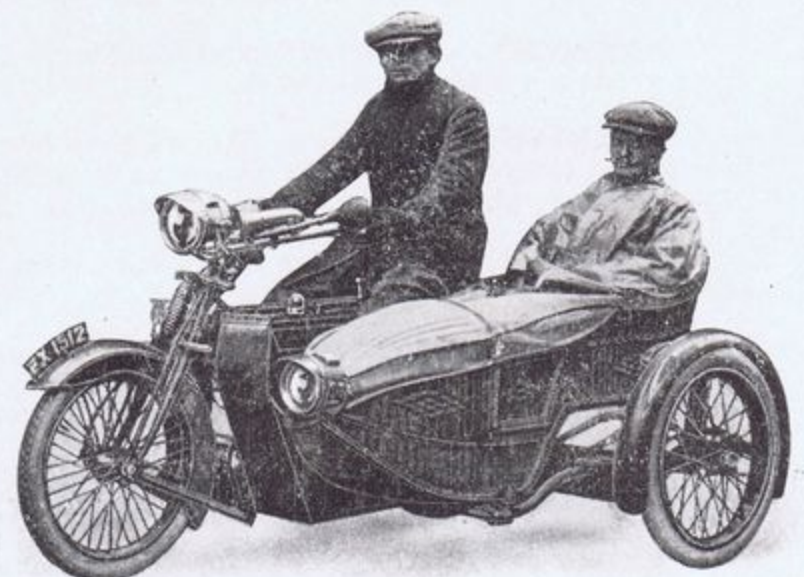

MR. C. H. R. NORRINGTON, the only rider to receive a Gold Medal in the Bristol—Land's End—Bristol Trial.

MOTOR CYCLE GUARANTEE.

We give the following guarantee with our motor cycles, instead of the guarantee implied by statute, or otherwise, as to the quality or fitness of such machines for the purpose of motor cycling; any such implied guarantee being in all cases excluded. In the case of machines which have been used for "hiring out" purposes, or from which our trade mark or manufacturing number has been removed, no guarantee of any kind is given, or is to be implied.

We guarantee, subject to the conditions mentioned below, that all precautions which are usual and reasonable have been taken by us to secure excellence of materials and workmanship, but this guarantee is to extend and be in force for three months only from the date of purchase, and damages for which we make ourselves responsible under this guarantee are limited to the replacement of any part which may have proved defective. We undertake, subject to the conditions mentioned below, to make good at any time within three months any defects in these respects. As motor cycles are easily liable to derangement by neglect or misuse, this guarantee does not apply to defects caused by wear and tear, misuse or neglect.

The term "misuse" shall include amongst others the following acts:—

1. The attaching of a side-car to the motor cycle in such a manner as to cause damage, or calculated to render the latter unsafe when ridden.
2. The use of a motor cycle, or of a motor cycle and side-car combined, when carrying more persons, or a greater weight, than that for which the machine was designed by the manufacturers.

Any motor cycle sent to us to be plated, enamelled, or repaired, **whether the repairs are required for the purpose of making good the defect before referred to or otherwise**, will be repaired upon the following conditions:—i.e., we guarantee that all precautions which are usual and reasonable have been taken by us to secure excellence of material and workmanship, such guarantee to extend and be in force for three months only from the time such work shall have been executed, and this guarantee is in lieu and in exclusion of any common law or statute warranty, and the damages recoverable are limited to the cost of any further work which may be necessary to amend and make good the work found to be defective.

CONDITIONS OF GUARANTEE.

If a defective part should be found in our motor cycles, **or in any part replaced**, it must be sent to us carriage paid, and accompanied by an intimation from the sender that he desires to have it repaired free of charge under our guarantee, and he must also furnish us at the same time with the number of the machine, the name of the agent from whom he purchased, and the date of the purchase, **or the date when the alleged defective part was replaced, as the case may be.**

Failing compliance with the above, no notice will be taken of anything which may arrive, but such articles will lie here at the risk of the senders, and this guarantee, and any implied guarantee, shall not be enforceable.

We guarantee only those machines which are bought either direct from us or from one of our duly appointed agents, and under no other conditions.

We do not guarantee the specialities of other firms, such as tyres, saddles, chains, lamps, etc., or of any component part supplied with our motor cycles, or otherwise.

The term "Agent" is used in a complimentary sense only, and those firms whom we style our agents are not authorised to advertise, incur any debts, or transact any business whatsoever on our account, other than the sale of goods which they may purchase from us; nor are they allowed to give any warranty or make any representation on our behalf other than those contained in the above Guarantee.

CONDITIONS OF SALE.

The prices appearing in this catalogue are **strictly net.**

All goods are sold subject only to the conditions of guarantee given above.

The 6 h.p. Enfield motor cycle and side-car combination is sold subject to the further condition that we cannot accept responsibility if used with any side-car other than one supplied by us.

PAYMENT.—One-third deposit must be paid on our acceptance of the order, and the balance upon receipt of our advice that goods are ready for despatch.

CARRIAGE.—Carriage in all cases must be paid by the customer. All goods are delivered free on rail at Redditch, and are signed for by the railway company as being received in good condition. The railway company then become the agents of the customer, who should make immediate claim on the carriers in case of damage.

PACKING.—Motor cycles are packed in specially constructed crates, which being charged at cost price are not returnable. Crates for models 140, 150 and 160, 5s. each; crates for model 180, 10s. each. Cases for export charged at cost price.

REPAIRS AND SUNDRIES.—These cannot be booked; our terms are net cash on receipt of pro-forma invoice. Machines or parts for repair must be sent carriage paid, and the name of the sender attached, or they cannot be received. Full instructions, with advice as to mode of despatch, should be posted same day.

When ordering sundries, customers are respectfully requested to quote our identification number for each part required; it is also desirable that the number of the machine, and number of engine should in all cases be given.

Please mark any communications relating to repairs or sundries, "Motor Repairs and Sundries Department."

NOTE.—We reserve the right to alter the prices, designs, specifications, etc., of any of the models or parts in this catalogue, and to **withdraw** or **substitute** models without notice.

MADE
LIKE A
GUN

ROYAL ENFIELD

MOTOR CYCLES

1914

