

ILLUSTRATED  
**SPARES LIST**  
FOR  
**PANTHER**  
MOTOR CYCLES  
MODELS 65 and 75



**PHELON & MOORE LTD**  
**CLECKHEATON**  
**YORKSHIRE**

**BARNSTORMERS.CO.NZ** Price **2/6**



ILLUSTRATED  
**SPARES LIST**

FOR

**PANTHER**

MOTOR CYCLES

MODELS 65 and 75

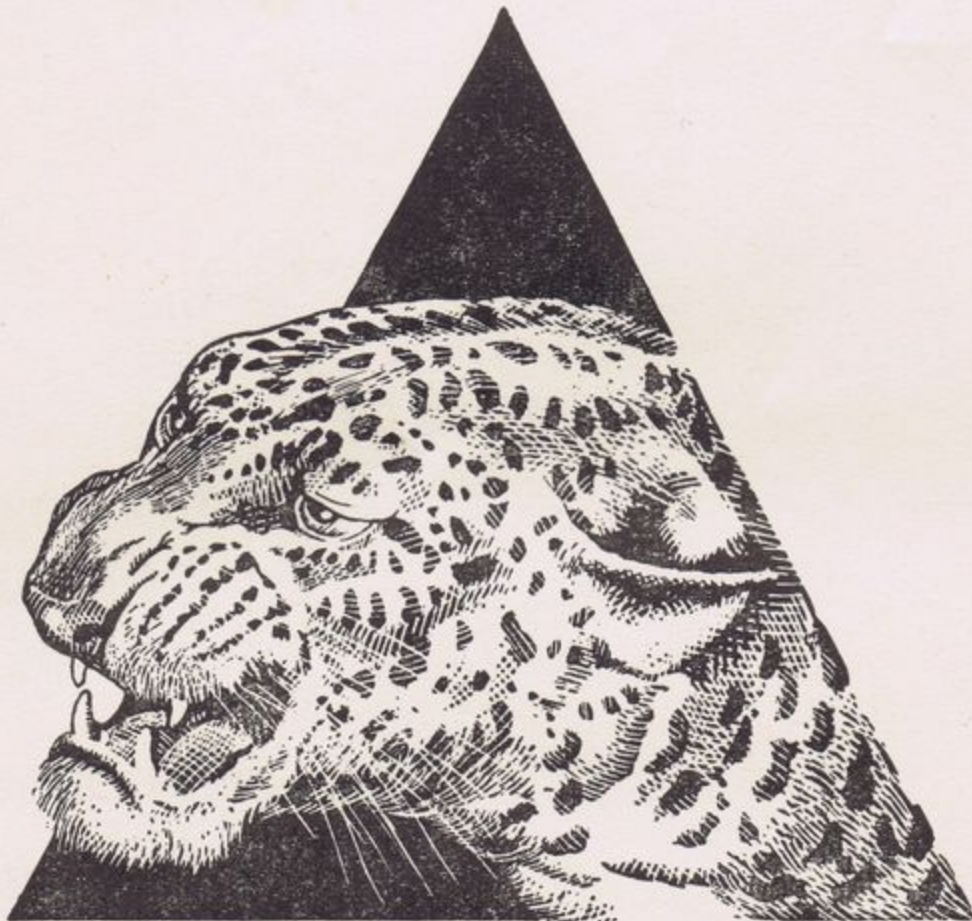

**PHELON & MOORE LTD**  
**CLECKHEATON**  
**YORKSHIRE**

[Barnstormers.co.nz](http://Barnstormers.co.nz)



# INSTRUCTIONS FOR PURCHASING PANTHER SPARES

Panther spare parts may be obtained from all officially appointed Panther Dealers. If the rider wishes to purchase direct from factory, the following points should be observed.

1. Identification of machine  
Quote the **full engine number as stamped on the crankcase**. Frame numbers and registration numbers are **useless** for identification purposes.
2. Identification of part  
Give the **Model of Machine, part number** (not the illustration number), **full description of part** and **quantity** of each article required.
3. Payment. (Home Sales)  
Payment is usually made by cash with order or against Pro Forma Invoice. Goods can be sent C.O.D. only provided the order is for a total value of 5/- or over.  
**Minimum** C.O.D. postage fee is 10 pence. Riders wishing to open accounts should write direct to the Works at Cleckheaton, for further information.
- Payment. (Export Sales)  
In view of difficulties existing at date of publication in connection with export business, overseas riders are advised to order through their local agent wherever possible. Terms for direct purchase are **cash sterling in England against Pro Forma Invoice**. If remittance is sent with order, allowance should be made for freight, packing and insurance.
4. Carriage & Packing  
All spares invoices are surcharged by five per cent. to cover cost of packing and carriage. Minimum surcharge is sixpence. Should it be necessary to use a special case or crate, this will be charged for over and above the five per cent. but full refund of this additional charge will be made on return of case or crate to factory. Carriage must be paid and the packaging must be in good condition.
5. Prices & Specification  
Prices and specifications are subject to modification and alteration without notice. Prices do not include packing and postage.
6. Repairs  
Estimates will be given for repairs to parts sent to us. No charge is made for this but it is necessary in some cases to charge for dismantling and reassembling parts for inspection prior to giving estimate. In the case of major overhauls it is essential to write to the Works first and arrange a date for acceptance of machine or unit. We do not undertake repairs to proprietary fittings.
7. Guarantee  
All parts sold as spares that are manufactured by us are subject to the same limited guarantee as that issued with each new motorcycle. The Guarantee is rendered null and void and no responsibility can be accepted for any of our machines to which parts not manufactured by us have been fitted.



8. Addressing

Write your **full name and address** clearly in **BLOCK LETTERS** on your spares orders. Also see that your name and address are attached to any drawing or pattern that is enclosed with the order. Address all correspondence to—Phelon & Moore Ltd., Cleckheaton, Yorkshire. Delays will occur if matters relating to more than one department are contained on the same sheet of a letter. A separate letter should be sent to each department especially in the cases of orders for spare parts and requests for technical advice.

9. Hours of opening

The Service Department is open, for the convenience of personal callers as follows :—Mondays to Fridays, 9 a.m. to 12 noon, 1 p.m. to 5 p.m. **CLOSED SATURDAYS.**

**We wish to give you the very best spares service we can. To help us do this, may we ask you once again to bear the following points in mind when ordering your spares.**

1. The **Model** of your Machine.
2. The **Engine** number.
3. Your full name and address in **BLOCK LETTERS.**
4. The **PART NUMBERS** of the spares required.
5. A **description** of the part.
6. A **Labelled Pattern or Drawing** if necessary.
7. **The quantity** of each item required.
8. Instructions re **payment** and **despatch.**



## List of Contents

DESCRIPTION	PAGE
ILLUSTRATIONS ... ..	i-xvi inclusive
CRANK CASES ... ..	1
FLYWHEELS ... ..	1
CYLINDER ... ..	1
CYLINDER HEAD ... ..	3
ROCKER BOX & ROCKERS ... ..	4
TAPPET ASSEMBLY ... ..	4
TIMING GEAR & OIL PUMP ... ..	4
ENGINE SPROCKET PARTS ... ..	5
EXHAUST PIPE & SILENCERS ... ..	5
CARBURETTOR MOD. 65 & MOD. 75 ... ..	6
FRAME ... ..	7
STANDS ... ..	8
FOOTRESTS ... ..	8
SADDLES ... ..	9
TANKS ... ..	9
CHAIN CASE ... ..	9
FRONT MUDGUARD ... ..	10
REAR MUDGUARD ... ..	11
DOWTY OLEOMATIC FORK ... ..	11 & 12
GEAR BOX (M65) 3 SPEED ... ..	12, 13 & 14
GEAR BOX (M75) 4 SPEED ... ..	15, 16 & 17
FRONT WHEEL & BRAKE PARTS ... ..	17, 18
REAR WHEEL & BRAKE PARTS ... ..	18, 19



DESCRIPTION	PAGE
SPEEDOMETER & PARTS ... ..	19 & 20
CHAINS ... ..	20
HANDLEBAR WITH CONTROLS & WIRES ... ..	20
CONTROL WIRES ... ..	21
HEADLAMPS & PARTS ... ..	21, 22 & 23
IGNITION COIL ... ..	23
DISTRIBUTOR ... ..	23 & 24
DYNAMO ... ..	24
BATTERY ... ..	25
MAGNETO ... ..	25
VOLTAGE CONTROL UNIT ... ..	25
HORN ... ..	25
TOOLS & ACCESSORIES ... ..	26



Order  
on this  
number

Illus. No.	Part No.	DESCRIPTION	No. Per Mach
1	R1	Crank Case driving side with eng. shaft bush	1
2	R2	Crank Case timing side with eng. shaft bush	1
		Cam stud bush and tappet guides	1
103	R3	Engine shaft bush	2
32	R4	Cam stud bush, Crankcase	1
104	R5	Crankcase oil seal	1
25	R6	Tappet guides	2
14	R7	Oil filler cap	1
12	R8	Oil filler cap washer	1
11	R9	Oil filter	1
12	R10	Oil filter washer	1
80	R11	Crank Case bolt $\frac{1}{4}$ " x $4\frac{1}{2}$ "	5
82	R12	" " " (Top front) $\frac{1}{4}$ x $5\frac{23}{32}$ "	1
81	R13	" " " (Top rear) $\frac{1}{4}$ x $4\frac{7}{8}$ "	1
79	R14	" " " $\frac{5}{16}$ " x $4\frac{1}{4}$ "	1
	R15	Nut, Crank Case bolt $\frac{1}{4}$ " (large)	14
	R16	" " " " $\frac{5}{16}$ "	2
	R17	Oil filter gauze	1
	R18	Oil filter internal spring	1
84	R19	Crank case drain plug $\frac{3}{8}$ " whit.	1
85	R20	Drain plug leather washer $\frac{3}{8}$ "	1
	R21	$\frac{7}{16}$ " Plug screw (Timing side crank case)	1
	R22	$\frac{3}{16}$ " Whit plug screw (Timing side crank case)	1
	R22	$\frac{3}{16}$ " Whit plug screw (Timing side crank case)	1
	R23	$\frac{1}{4}$ " Plug screw (Timing side crank case)	1
13	R24	Oil filler gauge	1

## FLYWHEELS

	R41	Flywheel with shaft (driving side)	1
	R42	Flywheel with shaft (timing side)	1
38	R43	Flywheel only (driving or timing side)	2
39	R44	Flywheel shaft only (driving side)	1
40	R45	Flywheel shaft only (timing side)	1
44	R46	Flywheel shaft lock washers	2
43	R47	Flywheel shaft nut	2
41	R48	Crank pin bearing complete	1
44	R49	Crank pin lock washer	2
43	R50	Crank pin nut	2
42	R51	Connecting rod with small end bush	1
45	R52	Connecting rod small end bush	1
	R53	Connecting rod comp. with small end bush, crank pin bearing, lock washers and nuts	1
	R54	Crank pin roller $\frac{1}{4}$ x $\frac{1}{4}$	28

## CYLINDER

MOD. 65 ONLY

3	R55	Cylinder block	1
	R56	Piston complete with rings, gudgeon pin and circlips	1

BARNSTORMERS.CO.NZ



# ENGINE

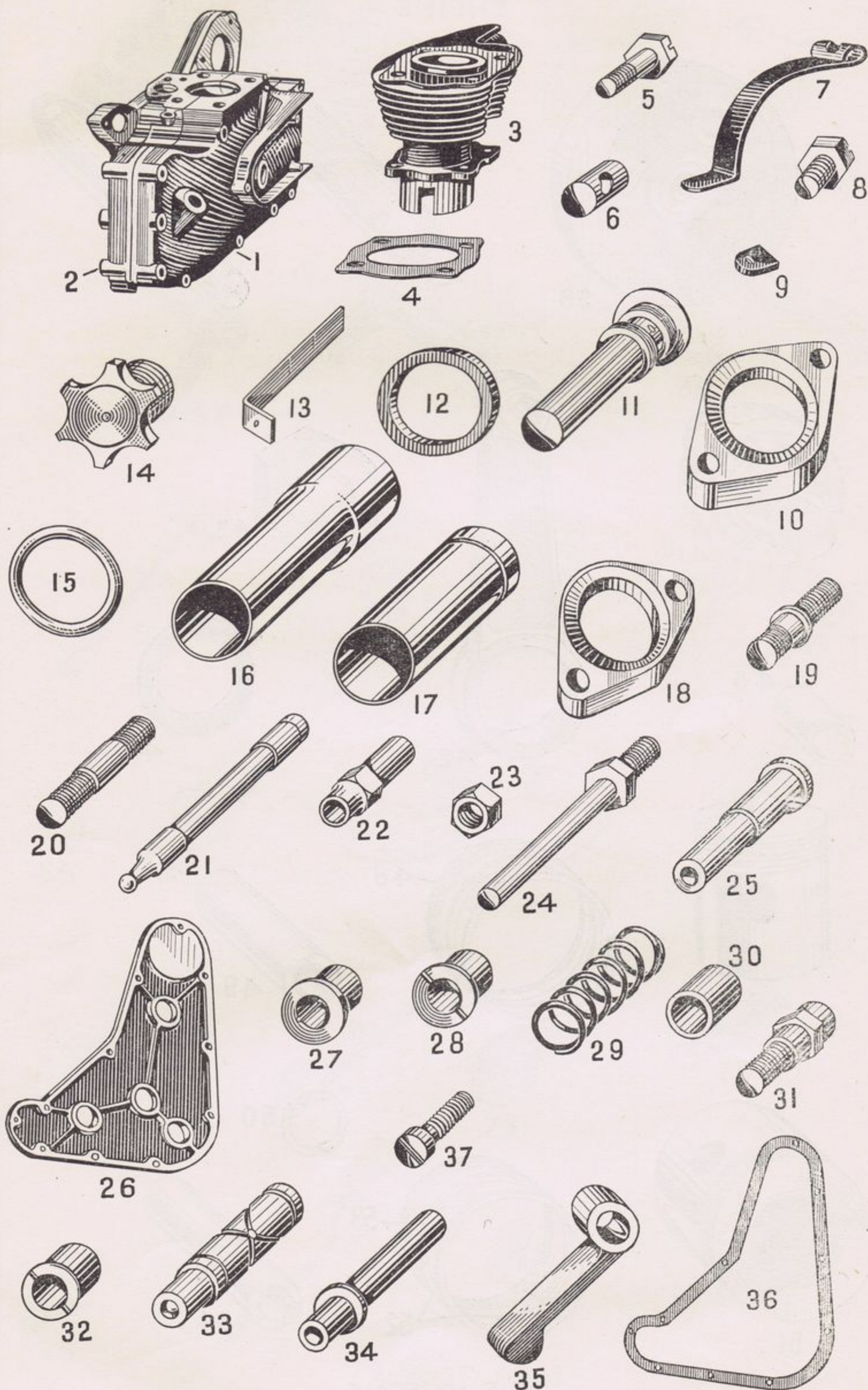

NOT TO SCALE



# ENGINE

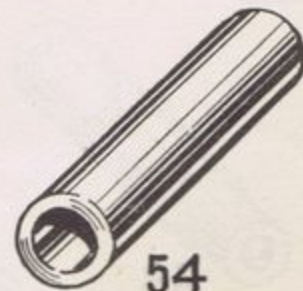
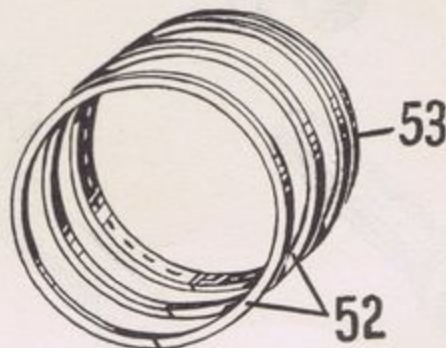
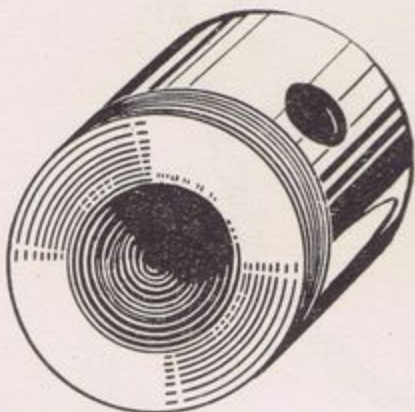
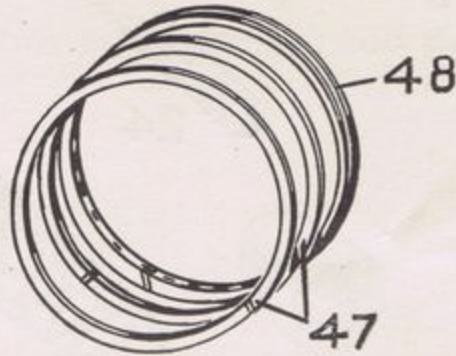
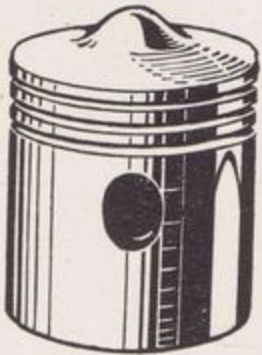
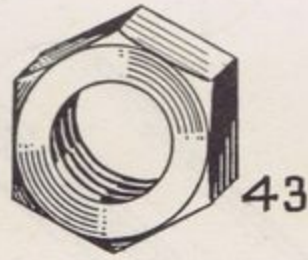
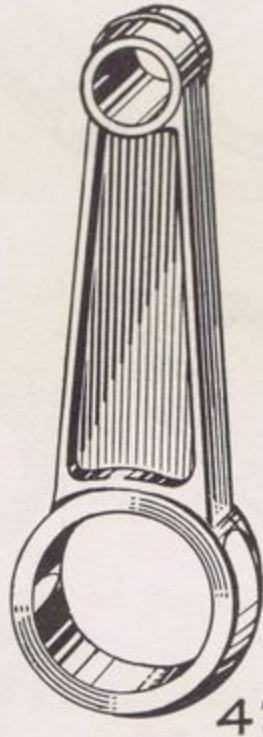
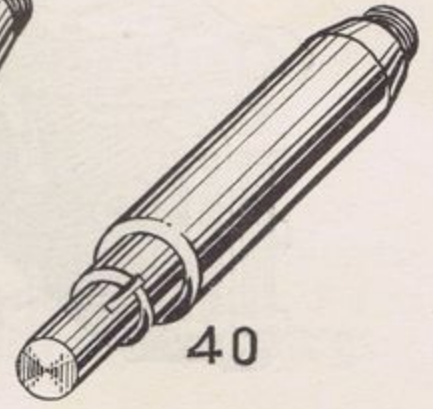
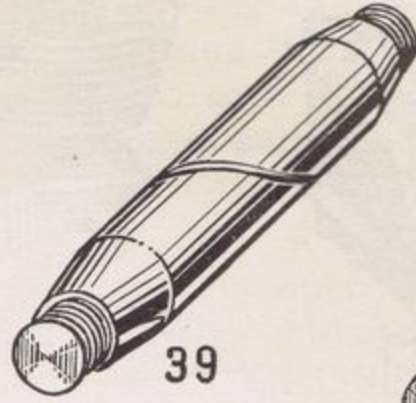
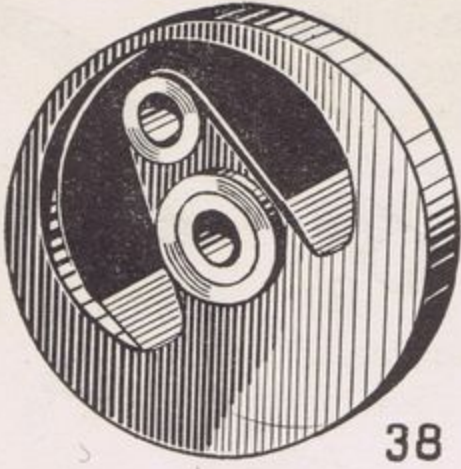

NOT TO SCALE



Order  
on this  
number

DESCRIPTION

Illus. No.	Part No.	DESCRIPTION	No. Per Mach
46	R57	Piston only	1
47	R58	Piston ring (Compression)	2
48	R59	Piston ring (Scraper)	1
49	R60	Gudgeon pin	1

MOD. 75 ONLY

3	R61	Cylinder block	1
	R62	Piston complete with rings, gudgeon pin and circlips	1
51	R63	Piston only	1
52	R64	Piston ring (compression)	2
53	R65	Piston ring (scraper)	1
54	R66	Gudgeon pin	1

MODELS 65 and 75

50	R67	Gudgeon pin circlip	2
4	R68	Cylinder base gasket	1
19	R69	Cylinder base stud	4
	R70	Cylinder base stud nut $\frac{3}{8}$ "	4
	R71	Cylinder base stud spring washers $\frac{3}{8}$ "	4
20	R72	Cylinder block to head stud	4
	R73	Cylinder block to head stud nut, $\frac{3}{8}$ "	4
	R74	Cylinder block to head stud spring washer $\frac{3}{8}$ "	4

OVERSIZE PISTONS—MODEL 65

	R75	Piston complete with rings, gudgeon pin and circlips, .010" oversize	1
	R76	Piston complete with rings, gudgeon pin and circlips, .015" oversize	1
	R77	Piston complete with rings, gudgeon pin and circlips, .020" oversize	1
	R78	Piston complete with rings, gudgeon pin and circlips, .030" oversize	1
47	R79	Piston ring (compression) .010" oversize	2
47	R80	Piston ring (compression) .015" oversize	2
47	R81	Piston ring (compression) .020" oversize	2
47	R82	Piston ring (compression) .030" oversize	2
48	R83	Piston ring (scraper) .010" oversize	1
48	R84	Piston ring (scraper) .015" oversize	1
48	R85	Piston ring (scraper) .020" oversize	1
48	R86	Piston ring (scraper) .030" oversize	1



Illus. No.	Order on this number Part No.	DESCRIPTION	No. Per Mach
		<b>CYLINDER—Continued</b>	
		<b>MODEL 75</b>	
	R87	Piston complete with rings, gudgeon pin and circlips, .010" oversize ... ..	1
	R88	Piston complete with rings, gudgeon pin and circlips, .020" oversize ... ..	1
	R89	Piston complete with rings, gudgeon pin and circlips, .030" oversize ... ..	1
52	R90	Piston ring (compression) .010" oversize ... ..	2
52	R91	Piston ring (compression) .020" oversize ... ..	2
52	R92	Piston ring (compression) .030" oversize ... ..	2
53	R93	Piston ring (scraper) .010" oversize ... ..	1
53	R99	Piston ring (scraper) .020" oversize ... ..	1
53	R100	Piston ring (scraper) .030" oversize ... ..	1

## CYLINDER HEAD

### MODEL 65 ONLY

55	R101	Cylinder head with valve guides ... ..	1
----	------	--	---

### MODEL 75 ONLY

55	R102	Cylinder head with valve guides ... ..	1
----	------	--	---

### MODELS 65 & 75

78	R103	Cylinder head copper gasket ... ..	1
61	R104	Valve (inlet or exhaust) ... ..	2
63	R105	Valve spring outer ... ..	2
62	R106	Valve spring inner ... ..	2
65	R107	Valve spring seat ... ..	2
64	R108	Valve spring washer ... ..	2
66	R109	Valve split collar ... ..	2prs
67	R110	Valve guide ... ..	2
76	R111	Valve oil pipe ... ..	1
77	R112	Valve oil pipe union (cylinder head) ... ..	1
90	R113	Valve oil pipe union fibre washer ... ..	2
201	R114	Cylinder head stay ... ..	1
200	R115	Cylinder head stay adjustable clevis ... ..	1
199	R116	Cylinder head stay bolt $\frac{1}{4} \times \frac{3}{4}$ HH ... ..	2
	R117	Cylinder head stay bolt nut $\frac{1}{4}$ " ... ..	2
	R118	Sparking plug ... ..	1
	R119	Sparking plug C & A washer ... ..	1
89	R120	Valve oil pipe union (crank case) ... ..	1



ENGINE

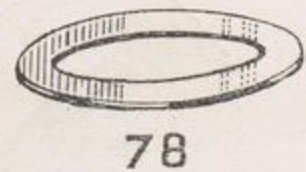
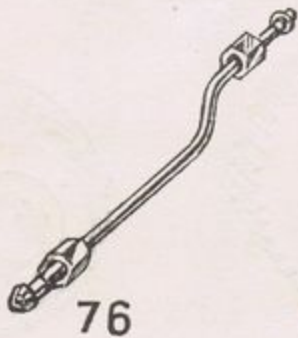
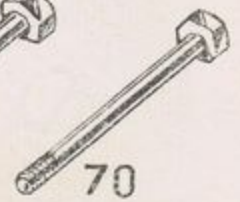
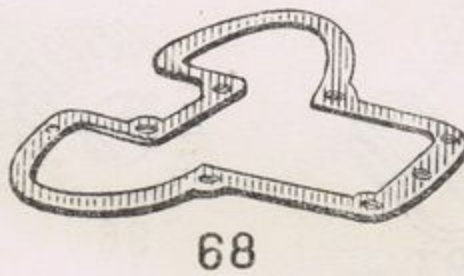
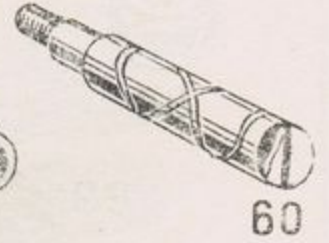
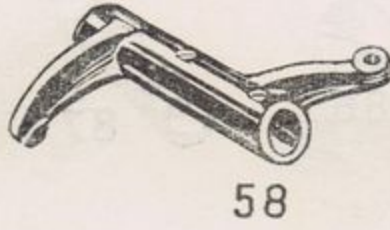
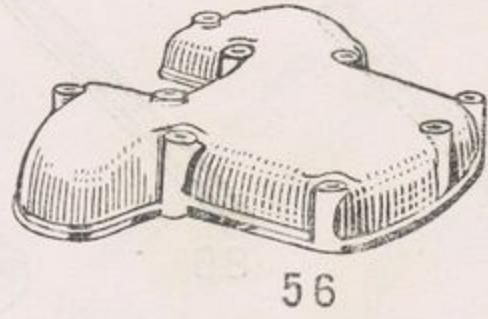
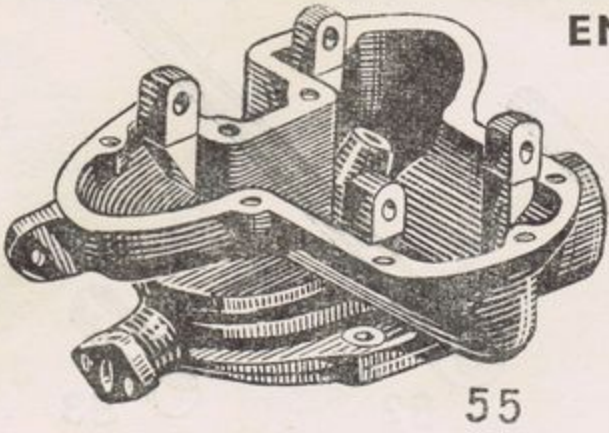

NOT TO SCALE



Order  
on this  
number

DESCRIPTION

Illus. No.	Part No.		No. Per Mach
<b>ROCKER BOX &amp; ROCKERS</b>			
56	R131	Rocker cover ... ..	1
68	R132	Rocker cover gasket ... ..	1
69	R133	Rocker cover screw $\frac{1}{4} \times 1\frac{13}{16}$ " ... ..	8
70	R134	Rocker cover screw $\frac{1}{4} \times 2\frac{1}{16}$ " ... ..	1
57	R135	Exhaust rocker ... ..	1
58	R136	Inlet rocker ... ..	1
75	R137	Rocker ball end ... ..	2
60	R138	Exhaust rocker shaft ... ..	1
59	R139	Inlet rocker shaft ... ..	1
	R94	Rocker shaft nut $\frac{3}{8}$ " ... ..	2
	R95	Rocker shaft spring washer $\frac{3}{8}$ " ... ..	2
88	R140	Inlet rocker shaft plug screw $\frac{1}{4} \times \frac{7}{16}$ " ... ..	1
72	R141	Valve lifter ... ..	1
73	R142	Valve lifter steel bush ... ..	1
71	R143	Valve lifter lever ... ..	1
74	R144	Valve lifter spring ... ..	1
	R117	Valve lifter lever nut $\frac{1}{4}$ " ... ..	1
	R145	Valve lifter lever flat washer $\frac{1}{4}$ " ... ..	3

**TAPPET ASSEMBLY**

16	R161	Tappet cover tube (top) ... ..	1
17	R162	Tappet cover tube (bottom) ... ..	1
15	R163	Tappet oil seal ... ..	2
10	R164	Tappet tube flange (top) ... ..	1
18	R165	Tappet tube flange (bottom) ... ..	1
83	R166	Tappet tube stud (top and bottom) ... ..	4
	R117	Tappet tube stud nut (top and bottom) $\frac{1}{4}$ " ... ..	4
21	R167	Valve push rod with ends ... ..	2
	R168	Valve push rod tube only ... ..	2
	R169	Valve push rod cup end (top) ... ..	2
	R170	Valve push rod ball end (bottom) ... ..	2
24	R171	Tappet rod ... ..	2
22	R172	Tappet rod adjuster nut ... ..	2
23	R173	Tappet rod lock nut ... ..	2

**TIMING GEAR & OIL PUMP**

MODEL 65 ONLY

26	R181	Timing cover with three bushes ... ..	1
----	------	---------------------------------------	---

MODEL 75 ONLY

26	R182	Timing cover with three bushes ... ..	1
----	------	---------------------------------------	---



Order  
on this  
number

DESCRIPTION

Illus. No.	Part No.	DESCRIPTION	No. Per Mach
		<b>TIMING GEAR &amp; OIL PUMP</b> —Continued	
		MODELS 65 AND 75	
	R183	$\frac{3}{16}$ "Whit. plug grub screw (Timing cover)	1
36	R184	Timing cover gasket	1
37	R185	Timing cover screw $\frac{1}{4} \times \frac{11}{16}$ " CH	10
27	R186	Eng. shaft or cam stud bush in timing case	2
28	R187	Tappet lever stud bush	1
98	R188	Eng. shaft main pinion	1
95	R189	Eng. shaft main pinion key	1
107	R190	Cam with wheel	1
33	R191	Cam stud	1
96	R192	Idler wheel with bush	1
97	R193	Idler wheel bush	1
99	R194	Dynamo pinion	1
105	R195	Dynamo pinion fixing screw	1
	R196	Dynamo pinion fixing spring washer	1
35	R197	Tappet lever	2
34	R198	Tappet lever stud	1
31	R199	Oil pump stud	1
	R200	Intermediate gear wheel with rotor and plunger	1
91	R201	Intermediate wheel only	1
92	R202	Oil pump rotor	1
94	R203	Oil pump rotor rivets	4
93	R204	Oil pump plunger	1
29	R205	Oil pump thrust spring	1
30	R206	Oil pump thrust spring cap	1
88	R207	Oil release valve screw	1
87	R208	Oil release valve spring	1
86	R209	Oil release valve ball $\frac{1}{4}$ "	1

**ENGINE SPROCKET PARTS**

115	R221	Engine sprocket	1
116	R222	Engine sprocket 17T	1
116	R223	Engine sprocket 19T	1
117	R224	Engine sprocket cam	1
118	R225	Engine sprocket shock absorber spring	1
119	R226	Engine sprocket washer	1
120	R227	Engine sprocket nut with release valve	1
121	R228	Release valve disc	1
	R229	Rivet for release valve discs	1

**EXHAUST PIPE & SILENCERS**

111	R241	Exhaust pipe	1
110	R242	Exhaust pipe finned nut	1
113	R243	Silencer	1
112	R244	Silencer clip	1
114	R245	Silencer stay	1
	R246	Silencer clip clinch bolt $\frac{5}{16} \times \frac{7}{8}$ "	2
	R16	Silencer clip nuts $\frac{5}{16}$ "	3
	R247	Silencer clip spring washer $\frac{5}{16}$ "	3
	R248	Exhaust pipe (upswept)	1



# ENGINE

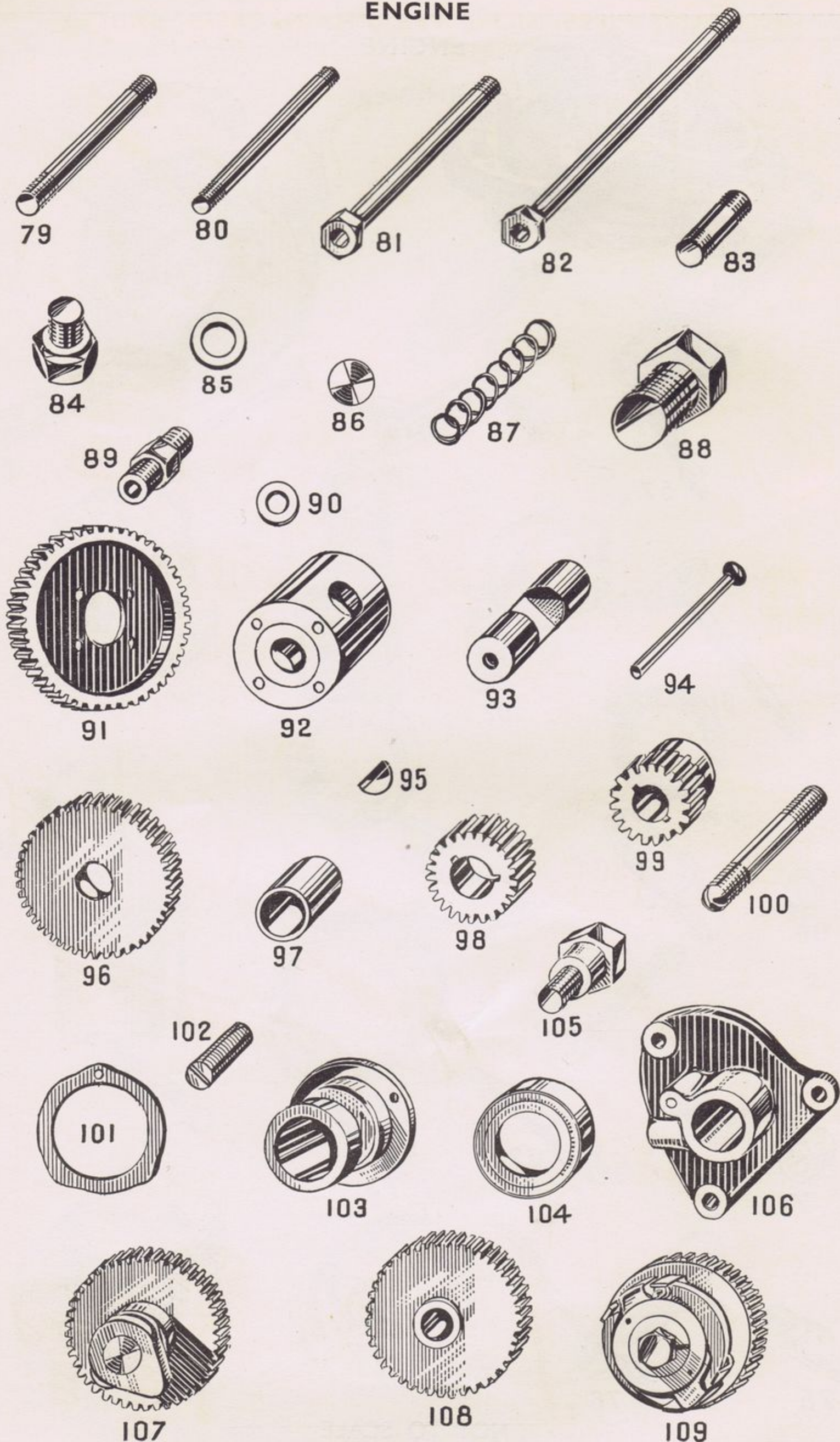

NOT TO SCALE

Barnstormers.co.nz



Order  
on this  
number



DESCRIPTION

Illus. No.	Part No.							No. Per Mach	
		<b>CARBURETTOR MOD. 65</b>							
	R261	Carburettor complete	...	...	...	...	...	1	
137	R262	Inlet flange washer	...	...	...	...	...	1	
	R263	Carburettor fixing screw $\frac{1}{4} \times \frac{5}{8}$ " HH	...	...	...	...	...	2	
146	R264	Mixing chamber body	...	...	...	...	...	1	
149	R265	Jet block	...	...	...	...	...	1	
159	R266	Mixing chamber top	...	...	...	...	...	1	
161	R267	Mixing chamber cap ring	...	...	...	...	...	1	
162	R268	Mixing chamber cap fixing spring	...	...	...	...	...	1	
	R269	Screw for fixing spring	...	...	...	...	...	1	
160	R270	Cable adjuster	...	...	...	...	...	2	
158	R271	Throttle valve	...	...	...	...	...	1	
153	R272	Throttle valve spring	...	...	...	...	...	1	
	R273	Throttle valve cotter pin	...	...	...	...	...	1	
148	R274	Taper needle	...	...	...	...	...	1	
154	R275	Taper needle clip	...	...	...	...	...	1	
147	R276	Air valve	...	...	...	...	...	1	
152	R277	Air valve guide	...	...	...	...	...	1	
163	R278	Air valve spring	...	...	...	...	...	1	
150	R279	Needle jet	...	...	...	...	...	1	
151	R280	Main jet	...	...	...	...	...	1	
144	R281	Mixing chamber union nut	...	...	...	...	...	1	
136	R282	Mixing chamber union nut washer	...	...	...	...	...	1	
155	R283	Pilot air adjusting screw	...	...	...	...	...	1	
156	R284	Pilot air adjusting spring	...	...	...	...	...	1	
157	R285	Throttle stop screw	...	...	...	...	...	1	
	R286	Throttle stop screw lock nut	...	...	...	...	...	1	
138	R287	Holding bolt for float chamber	...	...	...	...	...	1	
136	R288	Holding bolt fibre washers	...	...	...	...	...	2	
145	R289	Air intake tube	...	...	...	...	...	1	
135	R290	Float chamber body	...	...	...	...	...	1	
139	R291	Float chamber cover	...	...	...	...	...	1	
140	R292	Float tickler comp.	...	...	...	...	...	1	
	R293	Float tickler only	...	...	...	...	...	1	
	R294	Float tickler spring	...	...	...	...	...	1	
	R295	Float tickler cotter pin	...	...	...	...	...	1	
	R296	Float tickler stop	...	...	...	...	...	1	
143	R297	Float	...	...	...	...	...	1	
142	R298	Float needle valve	...	...	...	...	...	1	
	R299	Float chamber valve seating lock nut	...	...	...	...	...	1	
	R300	Float chamber valve seating washer	...	...	...	...	...	1	
	R301	Float chamber petrol union nut	...	...	...	...	...	1	
	R302	Float chamber petrol union nipple	...	...	...	...	...	1	

**CARBURETTOR MOD. 75**

	R311	Carburettor complete	...	...	...	...	...	1
146	R312	Mixing chamber body	...	...	...	...	...	1
149	R313	Jet block	...	...	...	...	...	1
159	R314	Mixing chamber top	...	...	...	...	...	1



# CARBURETTOR

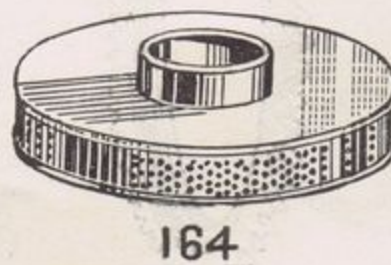
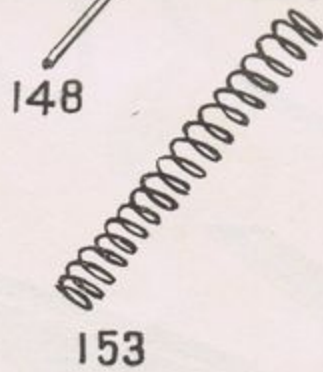
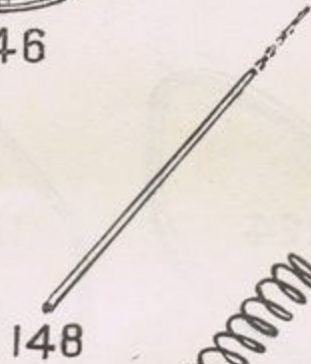
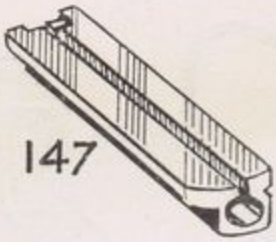
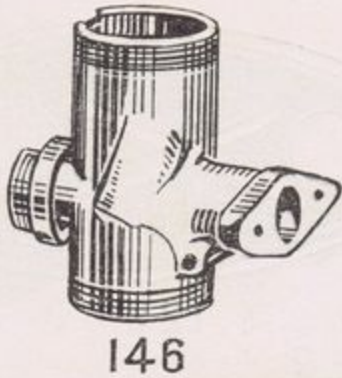
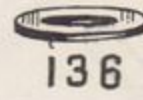
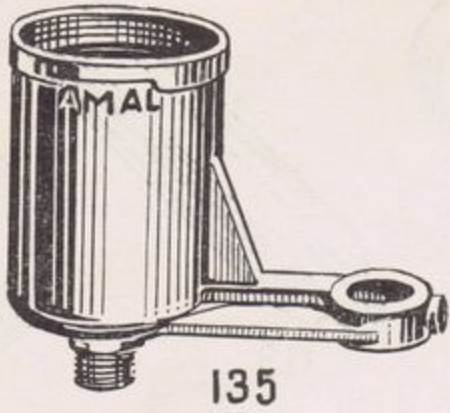

NOT TO SCALE  
BARNSTORMERS.CO.NZ



Order  
on this  
number

DESCRIPTION

No.  
Per  
Mach

**CARBURETTOR MOD. 75**—Continued

Illus. No.	Part No.	DESCRIPTION	No. Per Mach
161	R315	Mixing chamber cap ring ... ..	1
162	R316	Mixing chamber cap fixing spring ... ..	1
	R317	Screw for fixing spring ... ..	1
160	R318	Cable adjuster ... ..	2
158	R319	Throttle valve ... ..	1
153	R320	Throttle valve spring ... ..	1
	R321	Throttle valve cotter pin ... ..	1
148	R322	Taper needle ... ..	1
154	R323	Taper needle clip ... ..	1
147	R324	Air valve ... ..	1
152	R325	Air valve guide ... ..	1
163	R326	Air valve spring ... ..	1
150	R327	Needle jet ... ..	1
151	R328	Main jet ... ..	1
144	R329	Mixing chamber union nut ... ..	1
	R330	Mixing chamber union nut washer ... ..	1
155	R331	Pilot air adjusting screw ... ..	1
156	R332	Pilot air adjusting screw spring ... ..	1
157	R333	Throttle stop screw ... ..	1
	R334	Throttle stop screw locknut ... ..	1
138	R335	Holding bolt for float chamber ... ..	1
136	R336	Holding bolt fibre washer ... ..	2
145	R337	Air intake tube ... ..	1
135	R338	Float chamber body ... ..	1
139	R339	Float chamber cover ... ..	1
141	R340	Float chamber cover lock screw ... ..	1
140	R341	Float chamber tickler complete ... ..	1
	R342	Float chamber tickler only ... ..	1
	R343	Float chamber tickler spring ... ..	1
	R344	Float chamber tickler cotter pin ... ..	1
	R345	Float chamber tickler stop ... ..	1
143	R346	Float ... ..	1
142	R347	Float needle valve ... ..	1
	R348	Float chamber valve seating locknut ... ..	1
	R349	Float chamber valve seating fibre washer ... ..	1
	R350	Float chamber petrol union nut ... ..	1
	R351	Float chamber petrol union nipple ... ..	1
164	R352	Air filter ... ..	1
165	R353	Air filter elbow ... ..	1

**FRAME**

166	R401	Front frame ... ..	1
171	R402	Frame and ball head ball races ... ..	3
168	R403	R.H. Rear frame Model 65 ... ..	1
169	R404	L.H. Rear frame Model 65 ... ..	1
168	R405	R.H. Rear frame Model 75 ... ..	1
169	R406	L.H. Rear frame Model 75 ... ..	1
175	R407	Back stay bolt (top) $\frac{3}{8}$ " x $4\frac{1}{2}$ " ... ..	1
192	R408	Rear frame and stand bolt $\frac{3}{8}$ " x $8\frac{7}{8}$ " ... ..	1
79	R409	Front engine and frame bolts $\frac{3}{8}$ " x $3\frac{13}{16}$ " ... ..	3



Order on this number	DESCRIPTION	No. Per Mach	
Illus. No.	Part No.		
	<b>FRAME—Continued</b>		
80	R410	Bottom front frame bolt $\frac{3}{8}$ " x $4\frac{7}{16}$ " ... .. .	1
80	R411	Rear engine and frame bolt $\frac{3}{8}$ " x $4\frac{7}{16}$ " ... .. .	3
	R94	$\frac{3}{8}$ " Hexagon nuts ... .. .	18
	R95	$\frac{3}{8}$ " Spring washers ... .. .	18
179	R412	Front engine plate ... .. .	2
202	R413	Rear engine plate R.H. ... .. .	1
203	R414	Rear engine plate L.H. ... .. .	1

### STANDS

191	R431	Centre stand model 65 ... .. .	1
192	R432	Centre stand bolt ... .. .	1
188	R433	Centre stand spring ... .. .	1
189	R434	Centre stand spring anchor ... .. .	1
190	R435	Centre stand spring anchor plate ... .. .	1
	R246	$\frac{5}{16}$ " x $\frac{7}{8}$ " H.H. screw ... .. .	1
	R116	$\frac{1}{4}$ " x $\frac{3}{4}$ " H.H. screw ... .. .	1
	R436	$\frac{1}{4}$ " Spring washer ... .. .	1
	R117	$\frac{1}{4}$ " nut ... .. .	1
183	R441	Rear stand model 75 ... .. .	1
181	R442	Rear stand screw with large washer ... .. .	2
	R443	Rear stand spring washers $\frac{3}{8}$ " D.C. ... .. .	2
	R16	$\frac{5}{16}$ " Hexagon nuts ... .. .	2
182	R444	Rear stand spring ... .. .	1
180	R445	Rear stand rubber stop ... .. .	2
184	R451	Prop stand model 75 ... .. .	1
188	R433	Prop stand spring ... .. .	1
187	R452	Prop stand bolt $\frac{3}{8}$ " x $1\frac{3}{8}$ " H.H. ... .. .	1
185	R453	Prop stand spring peg ... .. .	2
186	R454	Prop stand rubber ... .. .	1
	R455	$\frac{1}{4}$ " x $\frac{3}{4}$ " Round head screw ... .. .	1
	R145	$\frac{1}{4}$ " Flat washer ... .. .	1

### FOOTRESTS

197	R471	Footrest hanger R.H. ... .. .	1
195	R472	Footrest hanger L.H. ... .. .	1
198	R473	Footrest rubber ... .. .	2
196	R474	Footrest bolt $\frac{3}{8}$ " x 11" ... .. .	1
193	R475	Footrest distance piece long ... .. .	1
194	R476	Footrest distance piece short ... .. .	2
	R94	$\frac{3}{8}$ " nuts ... .. .	2
	R95	$\frac{3}{8}$ " Spring washers ... .. .	2
	R481	Pillion footrests complete ... .. .	1 pr
256	R482	Pillion footrest ... .. .	2
257	R483	Pillion footrest rubber ... .. .	2
258	R484	Pillion footrest screw ... .. .	2
	R485	$\frac{3}{8}$ " Double coil spring washer ... .. .	2
	R486	$\frac{5}{16}$ " Flat washer ... .. .	2
	R145	$\frac{1}{4}$ " Flat washer ... .. .	2
	R117	$\frac{1}{4}$ " Nut ... .. .	2



# FRAME FITTINGS

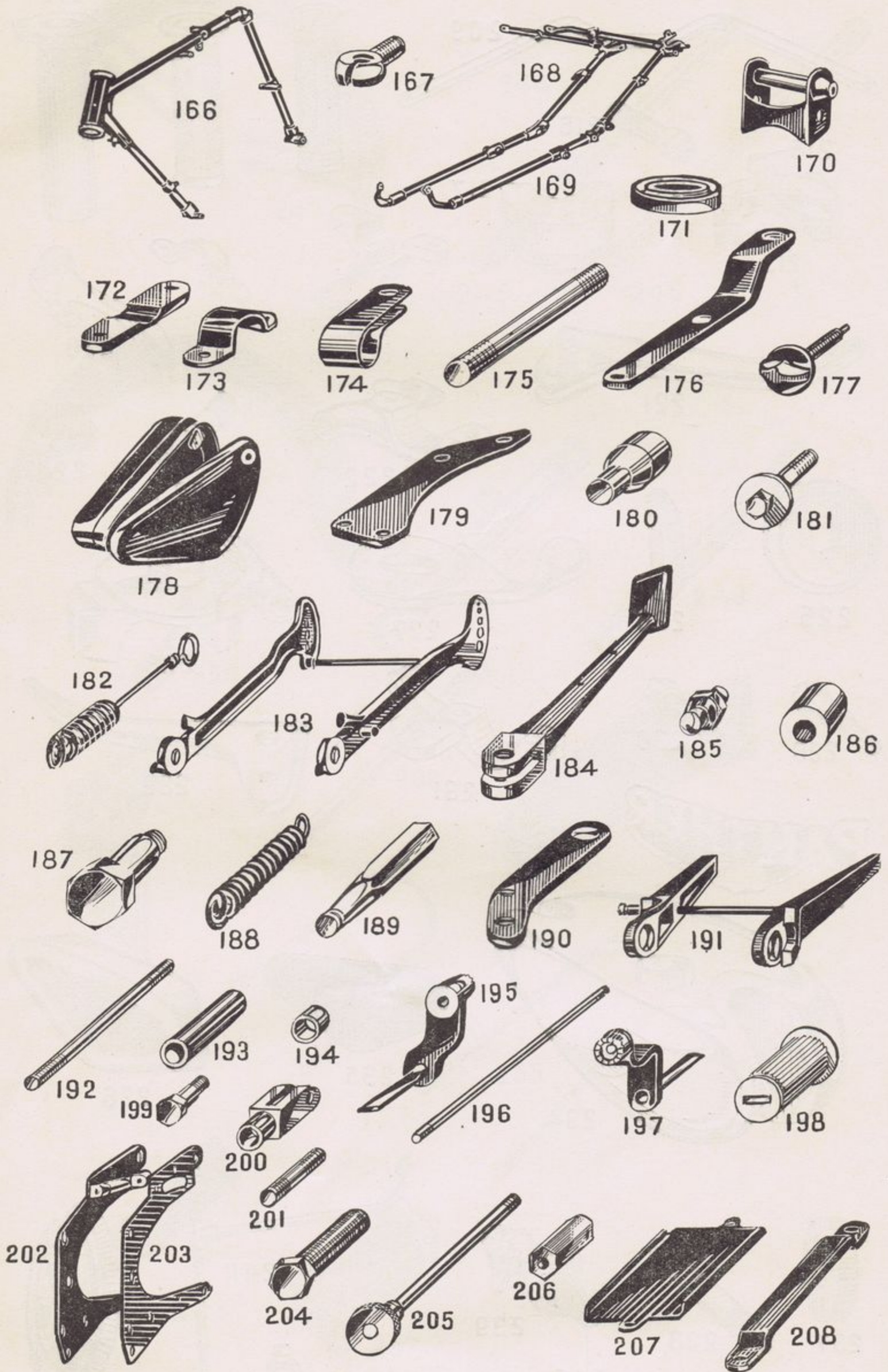

NOT TO SCALE



Illus. No.	Order on this number Part No.	DESCRIPTION	No. Per Mach
<b>SADDLES</b>			
134	R491	Saddle Lycett	1
	R492	Saddle nose bolt $\frac{5}{16}$ " x 2 $\frac{19}{32}$ "	1
133	R493	Saddle rear bolt $\frac{5}{16}$ " x 2 $\frac{1}{2}$ "	2
	R16	$\frac{5}{16}$ " Hexagon nuts	7
	R486	$\frac{5}{16}$ " Flat washer	1
	R494	Saddle rear spring	2
	R495	Saddle top cover	1
	R496	Seat spring 7 $\frac{1}{2}$ " long	13
	R497	Seat spring fitting	1
134	R501	Saddle Terry	1
	R502	Saddle rear spring	2
	R503	Saddle top cover	1
	R504	Seat spring (long)	13
	R505	Seat spring (short)	7
	R506	Seat spring fitting	1
170	R507	Saddle nose fitting	1

<b>TANKS</b>			
234	R521	Tank model 65	1
234	R522	Tank model 75	1
242	R523	Tank filler cap	1
	R524	Tank filler cap leather washer	1
233	R525	Tank name plates mod. 65	2
233	R526	Tank name plates mod. 75	2
	R527	Tank name fixing screws	4
	R528	Knee grip rubber R.H.	1
236	R529	Knee grip rubber L.H.	1
235	R530	Knee grip plates	2
238	R531	Tank fixing bolt (front)	1
238	R532	Tank fixing bolt (rear)	1
	R533	$\frac{5}{16}$ " Flat washers for fixing bolts	3
	R164	$\frac{5}{16}$ " Nut for fixing bolts	3
	R534	$\frac{1}{16}$ " Cotter pins	3
237	R535	Tank rubber packings	2
	R536	$\frac{1}{4}$ " x $\frac{1}{2}$ " H.H. screw for fixing knee grip plate	4
	R145	$\frac{1}{4}$ " Flat washer for fixing knee grip plate	16
239	R537	Petrol tap	2
85	R538	Petrol tap leather washer	2
241	R539	Petrol pipe	1
240	R540	Petrol tap filter gauze only	1

<b>CHAIN CASE</b>			
R561		Front chain case complete with Inspection cover, chromium plated rim. Model 75	1
R562		Front chain case complete with Inspection cover, enamelled rim. Model 65	1



EXHAUST PIPES, SILENCERS, CHAIN CASES, SADDLE



110



111



112

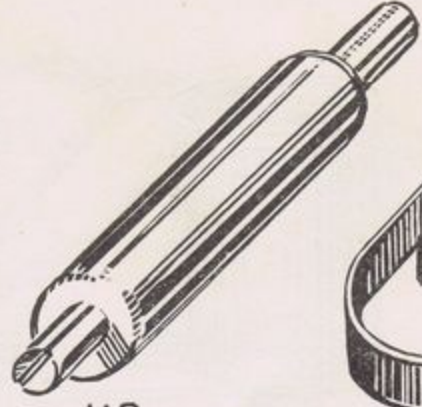

113



114



115



116



117



118



119



120



121

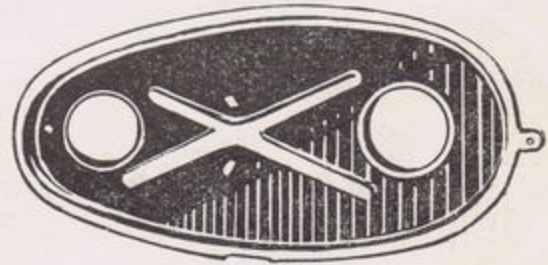

122

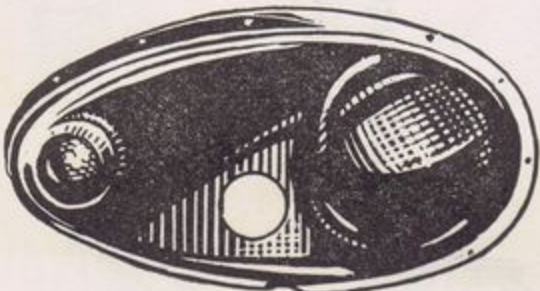

123



124

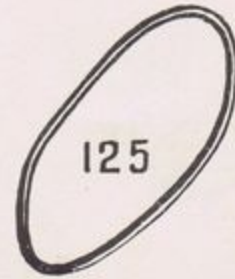

125



126



127



128



129

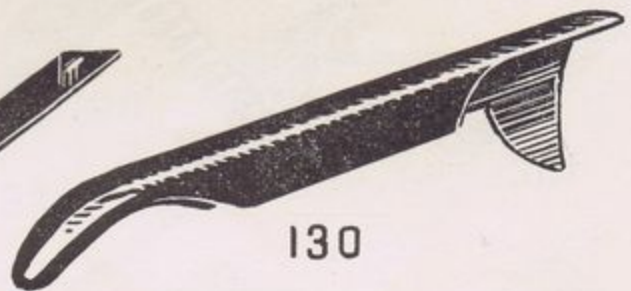

130



131

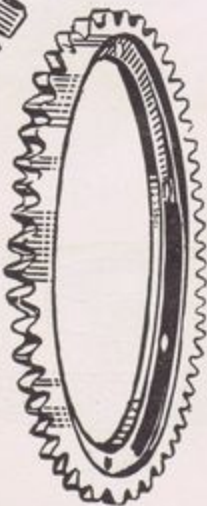

132



133

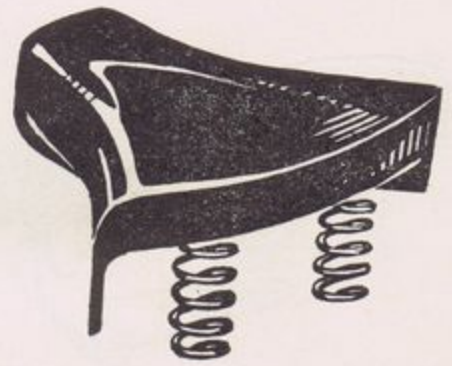

134

NOT TO SCALE

BARNSTORMERS.CO.NZ



Order  
on this  
number

DESCRIPTION

**CHAIN CASE**—Continued

Illus. No.	Part No.	DESCRIPTION	No. Per Mach
123	R563	Front chain case (outer portion) ... ..	1
122	R564	Front chain case (inner portion) ... ..	1
124	R565	Front chain case rim (chromium) mod. 75 ... ..	1
124	R566	Front chain case rim (enamelled) mod. 65 ... ..	1
125	R567	Front chain case rubber packing ... ..	1
127	R568	Front chain case inspection cap complete ... ..	1
	R569	Front chain case inspection cap washer ... ..	1
	R570	$\frac{3}{16}$ " x $\frac{3}{8}$ " C.H. chain case screws ... ..	10
	R571	$\frac{1}{4}$ " x $\frac{1}{2}$ " C.S. screws for fixing front chain case ... ..	2
128	R572	Large locking plate ... ..	1
131	R573	Small locking plate ... ..	1
	R536	$\frac{1}{4}$ " x $\frac{1}{2}$ " H.H. screw ... ..	3
	R574	$\frac{1}{4}$ " x $\frac{7}{8}$ " H.H. screw ... ..	1
	R145	$\frac{1}{4}$ " Flat washer ... ..	2
	R436	$\frac{1}{4}$ " Spring washer ... ..	4
	R117	$\frac{1}{4}$ " Nut ... ..	4
	R575	Chain case collar $\frac{3}{4}$ " x $\frac{3}{8}$ " ... ..	1
	R576	$\frac{3}{16}$ " x $\frac{3}{8}$ " R.H. screw for extension plate ... ..	1
	R577	$\frac{3}{16}$ " Flat washer ... ..	1
130	R578	Rear chain guard ... ..	1
129	R579	Rear chain guard extension ... ..	1
126	R580	Chain case bracket ... ..	1
178	R591	Toolbox ... ..	1
177	R592	Toolbox lid screw ... ..	1
176	R593	Toolbox stay ... ..	1
	R536	$\frac{1}{4}$ " x $\frac{1}{2}$ " H.H. Screw ... ..	4
	R117	$\frac{1}{4}$ " Nut ... ..	4
	R476	$\frac{1}{4}$ " Spring washer ... ..	4
	R145	$\frac{1}{4}$ " Flat washer ... ..	4

**FRONT MUDGUARD**

243	R601	Front mudguard mod. 65 ... ..	1
243	R602	Front mudguard mod. 75 ... ..	1
246	R603	Front mudguard centre stay R.H. ... ..	1
245	R604	Front mudguard centre stay L.H. ... ..	1
291	R605	Front mudguard stay bracket ... ..	1
253	R606	Front number plate ... ..	1
	R607	$\frac{1}{4}$ " x $1\frac{1}{8}$ " H.H. screw for mudguard stay ... ..	1
	R608	$\frac{1}{4}$ " x $1$ " H.H. screw for mudguard stay ... ..	1
	R574	$\frac{1}{4}$ " x $\frac{7}{8}$ " H.H. screw for mudguard stay ... ..	2
	R116	$\frac{1}{4}$ " x $\frac{3}{4}$ " H.H. screw for mudguard stay ... ..	1
	R536	$\frac{1}{4}$ " x $\frac{1}{2}$ " H.H. screw for mudguard stay ... ..	2
	R117	$\frac{1}{4}$ " Nut ... ..	7
	R436	$\frac{1}{4}$ " Spring washer ... ..	7
	R609	$\frac{3}{16}$ " x $\frac{1}{2}$ " H.H. screw for front number plate ... ..	2
	R610	$\frac{3}{16}$ " Nuts ... ..	2
	R611	$\frac{3}{16}$ " Spring washers ... ..	2



MUDGUARDS & FITTINGS

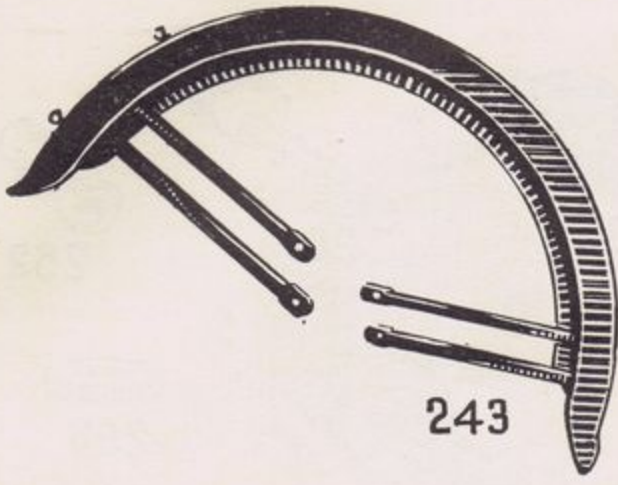

243



244

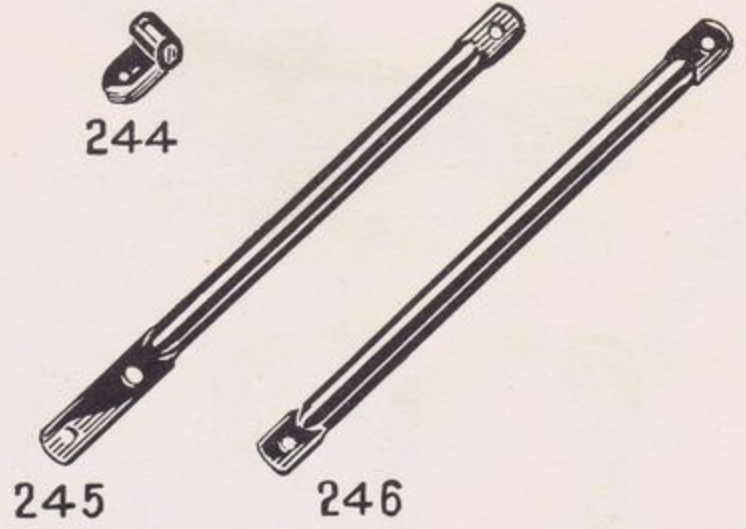

245

246

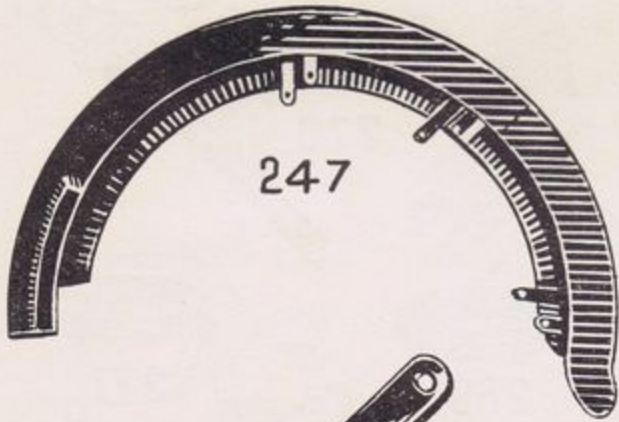

247



250

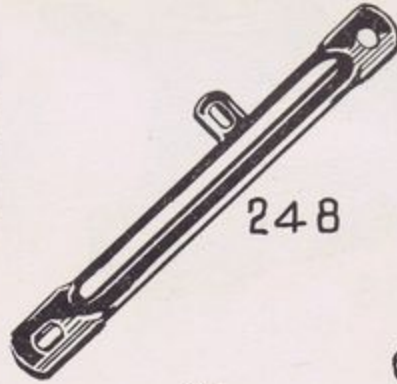

248

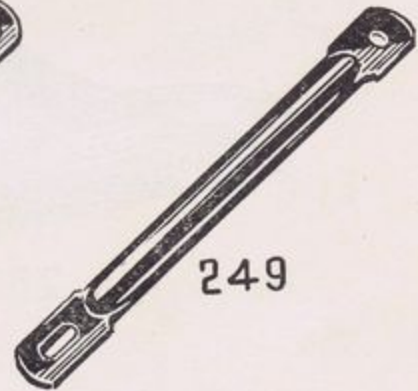

249



251

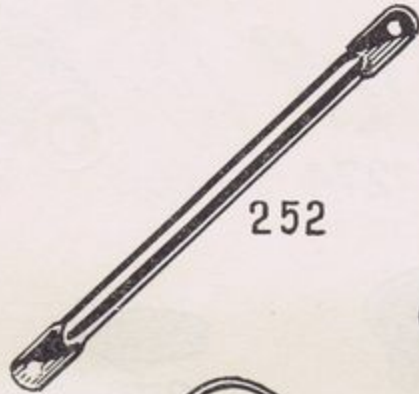

252

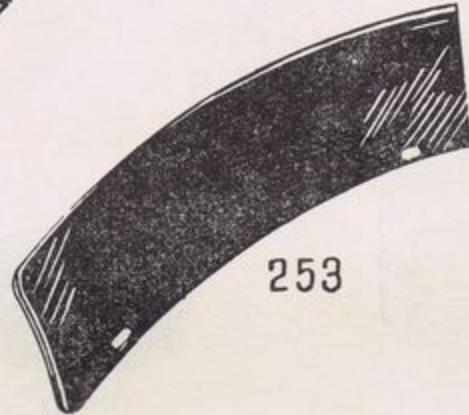

253



254



255



256



257



258

NOT TO SCALE



Order  
on this  
number

DESCRIPTION

Illus. No.	Part No.	DESCRIPTION	No. Per Mach
<b>REAR MUDGUARD</b>			
247	R621	Rear mudguard with tail piece mod. 65	1
247	R622	Rear mudguard with tail piece mod. 75	1
254	R623	Rear mudguard lifting loop mod. 75	1
249	R624	Rear mudguard short stay R.H.	1
248	R625	Rear mudguard short stay L.H. with lug	1
252	R626	Rear mudguard tail piece stay	2
250	R627	Rear mudguard bracket	1
	R536	$\frac{1}{4}$ " x $\frac{1}{2}$ " H.H. Screws	3
	R263	$\frac{1}{4}$ " x $\frac{5}{8}$ " H.H. Screws	9
	R574	$\frac{1}{4}$ " x $\frac{7}{8}$ " H.H. Screws	2
	R145	$\frac{1}{4}$ " Flat washer	15
	R436	$\frac{1}{4}$ " Spring washer	15
	R117	$\frac{1}{4}$ " Nut	14
	R628	$\frac{3}{4}$ " x $\frac{3}{8}$ " Collar	2
	R629	$\frac{5}{16}$ " x $1\frac{5}{8}$ " H.H. screws	2
	R247	$\frac{5}{16}$ " Spring washers	2
	R16	$\frac{5}{16}$ " Nuts	2
	R630	$\frac{3}{4}$ " x $\frac{3}{16}$ " Lifting loop collars	2
251	R631	Rear number plate	1
255	R632	Rear mudguard lifting loop mod. 65	1

**DOWTY OLEOMATIC FORK**

	R651	Fork complete	1
286	R652	Axle fitting and inner tube	2
283	R653	Outer tube complete	2
270	R654	Balance pipe and top fittings	1
284	R655	Shroud	2
268	R656	Fork crown fitting and steering tube	1
259	R657	Handlebar clip lug complete	1
275	R658	Piston	2
265	R659	Filler plug	2
277	R660	Spacer	1
272	R661	Inflation valve body	1
274	R662	Inflation valve core	1
	R663	Inflation valve cap	1
289	R664	Packing seal	2
280	R665	Lower buffer	2
279	R666	Static seal (piston)	2
266	R667	Static seal (filler plug)	2
271	R668	Static seal (top fitting)	2
288	R669	Scraper ring	2
278	R670	Sealing ring	2
273	R671	Bonded seal for inflation valve	1
276	R672	Seager circlip	2
281	R673	$\frac{7}{16}$ " Flat washer for lower buffer	2
282	R674	$\frac{7}{16}$ " B.S.F. Simmonds nut for lower buffer	2



# FRONT FORKS

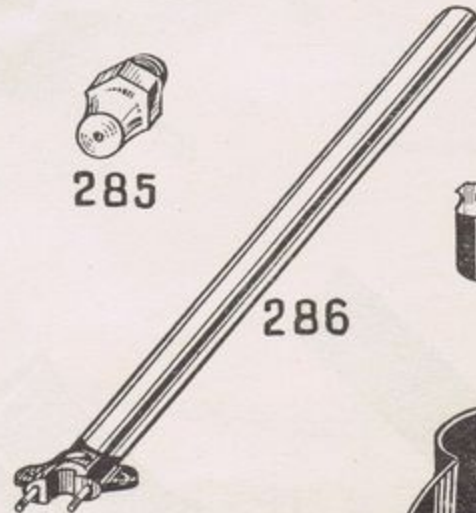
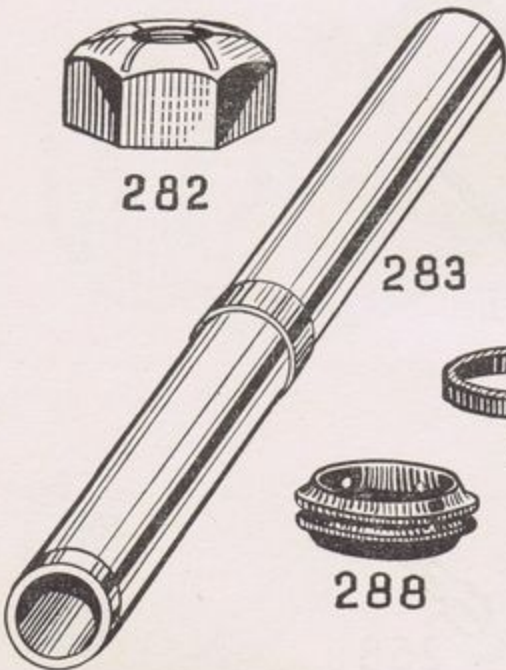
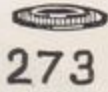
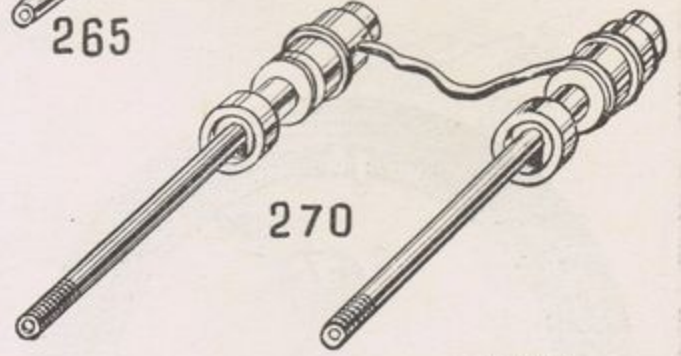
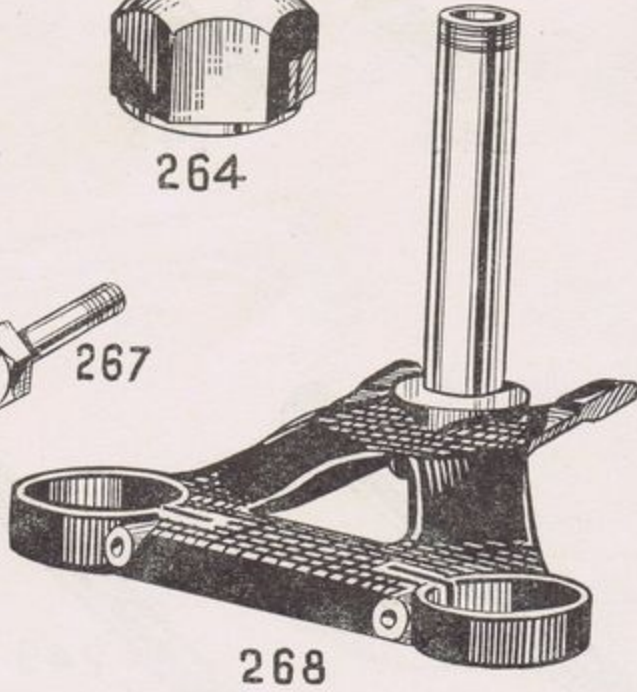
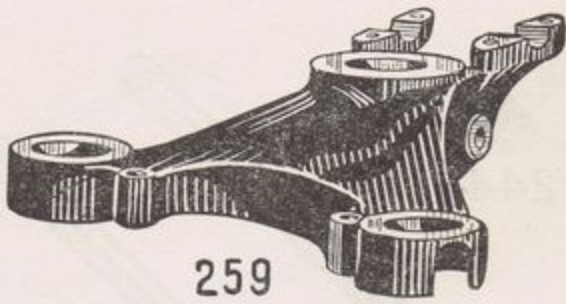

NOT TO SCALE



Order  
on this  
number

DESCRIPTION

Illus. No.	Part No.	DESCRIPTION	No. Per Mach
264	R675	Steering stem nut ... ..	1
261	R676	Handlebar clinch cotter bolt ... ..	1
262	R677	Handlebar clinch cotter ... ..	1
	R678	$\frac{3}{8}$ " Nut for cotter bolt ... ..	1
260	R679	Handlebar clip ... ..	2
263	R680	Handlebar clip bolt ... ..	4
285	R681	Tecalemit greaser ... ..	2
290	R682	Shroud screws ... ..	4
267	R683	$\frac{5}{16}$ " x $1\frac{3}{8}$ " H.H. pinch bolts ... ..	2
	R684	$\frac{5}{16}$ " Spring washer ... ..	2
100	R685	$\frac{1}{4}$ " Stud for axle fitting ... ..	4
	R686	$\frac{1}{4}$ " Nut ... ..	4
	R687	$\frac{1}{4}$ " Spring washer ... ..	4
269	R688	Fork stem ball race (plated) ... ..	1
171	R689	Head clip ball race ... ..	1
287	R620	Axle clip ... ..	2

**M65 GEAR BOX 3 SPEED**

MODEL 65

	R700	Gearbox complete with clutch and footchange ... ..	1
292	R701	Gearbox shell (bare) ... ..	1
293	R702	Kickstarter case (bare) ... ..	1
	R703	Kickstarter case locating piece ... ..	1
298	R704	Kickstarter case cover ... ..	1
	R705	Gearbox dowell stud $2\frac{9}{16}$ " x $\frac{1}{4}$ " ... ..	1
346	R706	Gearbox stud $1\frac{1}{32}$ " x $\frac{1}{4}$ " ... ..	1
348	R707	K.S. case stud $1\frac{1}{16}$ " x $\frac{1}{4}$ " ... ..	1
346	R708	K.S. case stud $1\frac{5}{32}$ " x $\frac{1}{4}$ " ... ..	3
	R709	Gearbox and K.S. case stud nuts $\frac{1}{4}$ " ... ..	3
311	R710	K.S. case cover screw $1\frac{3}{16}$ " x $\frac{1}{4}$ " ... ..	1
411	R711	Mainshaft ... ..	1
412	R712	Driving gear and bush 26T ... ..	1
319	R713	Mainshaft sliding gear 21T ... ..	1
320	R714	3rd Driving gear 16T ... ..	1
313	R715	Layshaft spindle ... ..	1
	R716	3rd Driving gear oil retaining washer ... ..	1
318	R717	Layshaft small gear 16T ... ..	1
314	R718	Layshaft sliding gear 21T ... ..	1
	R719	Layshaft large gear 26T ... ..	1
316	R720	Driving gear bush (two halves) ... ..	2
	R721	Layshaft bush fitted in K.S. Case ... ..	1
	R722	Layshaft bush fitted in gearbox shell ... ..	1
	R723	Layshaft bearing glut ... ..	1
	R724	Layshaft cover washer ... ..	1
343	R725	Driving gear bearing 30mm. x $2\frac{1}{4}$ " x $\frac{7}{16}$ " ... ..	1
317	R726	Driving gear washer ... ..	1

Barnstormers.co.nz



# GEAR BOX

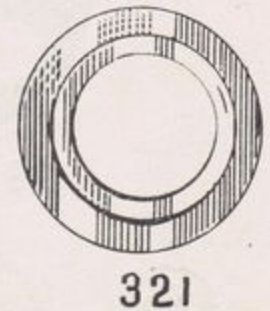
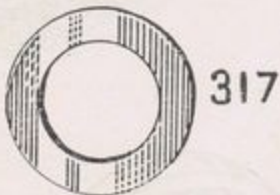
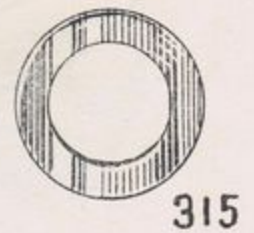
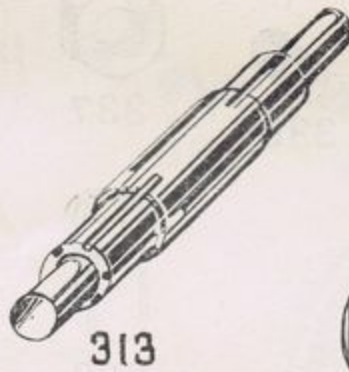
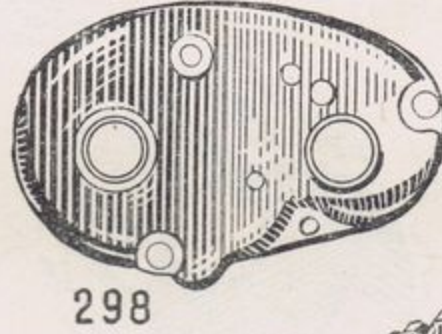
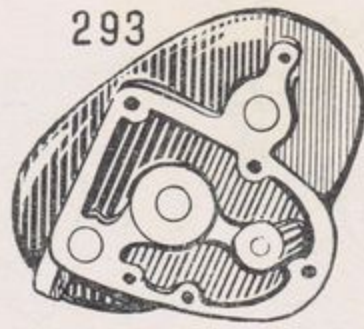
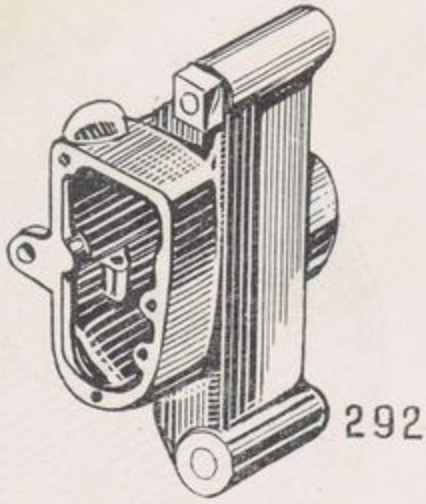

NOT TO SCALE



Order  
on this  
number

DESCRIPTION

**M65 GEAR BOX 3 SPEED**—Continued

Illus. No.	Part No.	DESCRIPTION	No. Per Mach
321	R727	Driving gear bearing dust cover ...	1
391	R728	Driving gear bearing retaining ring ...	1
342	R729	Mainshaft bearing 15mm. x 35mm. x 11mm. ...	1
315	R730	Mainshaft bearing washer ...	1
312	R731	Mainshaft bearing distance piece ...	1
303	R732	Bell crank inner lever ...	1
310	R733	Bell crank spindle ...	1
302	R734	Bell crank spindle washer ...	1
	R735	Bell crank spindle nut ...	1
309	R736	Operating block ...	1
363	R737	Gearbox pawl ...	1
368	R738	Gearbox pawl spring ...	1
351	R739	Gearbox pawl spring plug ...	1
305	R740	Gearbox inner lever ...	1
307	R741	Gearbox inner lever Trunnion ball ...	1
306	R742	Gearbox inner lever bolt ...	1
302	R743	Gearbox inner lever washer ...	1
308	R744	Pawl bearing screw ...	1
	R745	Pawl bearing nut $\frac{3}{16}$ " ...	1
	R746	Pawl bearing washer ...	1
299	R747	Pawl bearing cap ...	1
395	R748	Gearbox drain plug ...	1
396	R749	Gearbox drain plug washer ...	1
296	R750	Gearbox filler plug ...	1
285	R751	Gearbox grease nipple ...	1
322	R752	Gearbox driving sprocket 18T ...	1
316	R753	Driving sprocket spacing collar ...	1
323	R754	Driving gear nut ...	1
424	R755	K.S. ratchet pinion ...	1
423	R756	K.S. ratchet pinion bush ...	1
415	R757	K.S. ratchet pinion spring ...	1
419	R758	K.S. driving ratchet ...	1
364	R759	K.S. quadrant ...	1
363	R760	K.S. spindle ...	1
	R761	K.S. spindle bush (outer) ...	1
	R762	K.S. spindle bush (inner) ...	1
	R763	K.S. stop peg ...	1
358	R764	K.S. lever ...	1
359	R765	K.S. lever pedal ...	1
360	R766	K.S. lever pinch bolt ...	1
	R767	K.S. lever pinch bolt nut ...	1
385	R768	K.S. spring ...	1
	R769	K.S. spring pin ...	1
354	R770	K.S. stop peg rubber with band ...	1
418	R771	Mainshaft nut K.S. end ...	1
295	R772	Clutch lever ...	1
294	R773	Clutch lever pin ...	1
	R774	Clutch lever pin nut $\frac{1}{4}$ " ...	1
86	R775	Clutch lever ball $\frac{1}{4}$ " ...	1
430	R776	Clutch operating rod $10\frac{7}{8}$ " ...	1
325	R777	Chainwheel 37T $\frac{1}{2}$ " x $\frac{5}{16}$ " ...	1
394	R778	Roller race ...	1



Order  
on this  
number

DESCRIPTION

**M65 GEAR BOX 3 SPEED**—Continued

Illus. No.	Part No.							No. Per Mach
398	R779	Roller race washer	...	...	...	...	...	2
326	R780	Clutch rollers 35X (17 set)	...	...	...	...	...	17
324	R781	Clutch case (3 plate)	...	...	...	...	...	1
329	R782	Clutch centre (3 plate)	...	...	...	...	...	1
340	R783	Clutch plate (cork)	...	...	...	...	...	3
334	R784	Clutch plate (plain)	...	...	...	...	...	4
338	R785	Clutch spring plate	...	...	...	...	...	1
339	R786	Clutch spring cup ...	...	...	...	...	...	4
344	R787	Clutch springs	...	...	...	...	...	4
341	R788	Clutch spring adj. nut	...	...	...	...	...	4
335	R789	Clutch spring studs	...	...	...	...	...	4
328	R790	Buffer cover plate ...	...	...	...	...	...	4
327	R791	Buffer rubbers	...	...	...	...	...	4
332	R792	Chainwheel bolt and nut	...	...	...	...	...	4
336	R793	Spring plate adj. screw	...	...	...	...	...	1
337	R794	Spring plate adj. nut	...	...	...	...	...	1
331	R795	Mainshaft nut (clutch end)	...	...	...	...	...	1
330	R796	Mainshaft washer (clutch end)	...	...	...	...	...	1
304	R797	Footchange ratchet	...	...	...	...	...	1
301	R798	Footchange pawl ...	...	...	...	...	...	1
383	R799	Footchange pawl peg	...	...	...	...	...	1
297	R800	Control quadrant	...	...	...	...	...	1
	R801	Pawl spindle fitted in above	...	...	...	...	...	1
	R802	Control bush	...	...	...	...	...	1
	R803	Cover bush	...	...	...	...	...	1
300	R804	F.C. pawl spring	...	...	...	...	...	1
300	R805	F.C. main spring	...	...	...	...	...	1
	R806	F.C. main spring pin	...	...	...	...	...	1
421	R807	F.C. lever ...	...	...	...	...	...	1
420	R808	F.C. lever rubber	...	...	...	...	...	1
	R809	F.C. lever rubber peg	...	...	...	...	...	1
	R810	F.C. lever bolt	...	...	...	...	...	1
	R811	F.C. lever bolt nut	...	...	...	...	...	1
387	R812	F.C. indicator	...	...	...	...	...	1
	R813	F.C. indicator nut	...	...	...	...	...	1

MODEL 65/75

	R814	Gearbox fixing bolt $\frac{7}{16}$ " x $4\frac{1}{2}$ "	...	...	...	...	...	2
	R815	Gearbox adjuster nut $\frac{7}{16}$ "	...	...	...	...	...	1
	R816	$\frac{7}{16}$ " Nut	...	...	...	...	...	3
	R817	$\frac{7}{16}$ " Flat washer	...	...	...	...	...	2
	R818	$\frac{7}{16}$ " Spring washer	...	...	...	...	...	2
204	R819	Gearbox adjusting screw $\frac{5}{16}$ " x 2" S.H.H.	...	...	...	...	...	2
	R16	$\frac{5}{16}$ " nut	...	...	...	...	...	2

MODEL 75 ONLY

	R820	Gear box distance piece 1" x $\frac{1}{2}$ " x $\frac{1}{2}$ "	...	...	...	...	...	2
	R821	Gear box distance piece 1" x $\frac{1}{2}$ " x $\frac{1}{4}$ "	...	...	...	...	...	2



# GEAR BOX

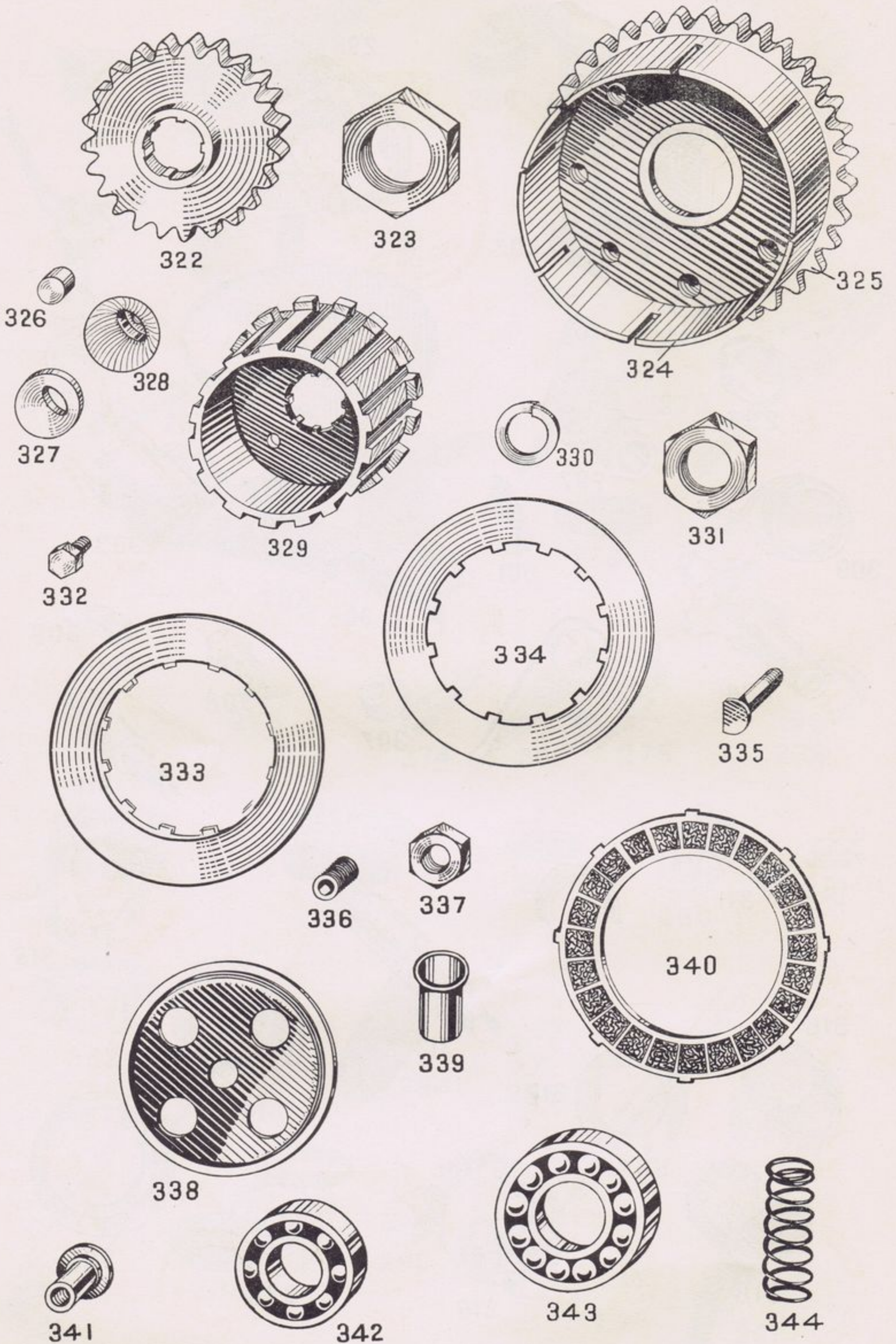

NOT TO SCALE



Order  
on this  
number

DESCRIPTION

No.  
Per  
Mach

**M75 GEARBOX 4 SPEED**

Illus. No.	Part No.	DESCRIPTION	No. Per Mach
	R850	Gearbox complete with clutch and footchange	1
345	R851	Gearbox shell (bare)	1
	R852	Gearbox joint washer	1
350	R853	Kickstarter case	1
355	R854	Kickstarter case cover	1
356	R855	Kickstarter case cover joint washer	1
409	R856	Gearbox drain plug	1
410	R857	Gearbox drain plug washer	1
347	R858	Gearbox stud $\frac{1}{4}'' \times 1''$	2
346	R859	Gearbox stud $\frac{5}{16}'' \times 1\frac{1}{16}''$	2
348	R860	Gearbox stud $\frac{5}{16}'' \times 3\frac{3}{16}''$	2
353	R861	Kickstarter case stud $\frac{1}{4}'' \times 2\frac{1}{4}''$	3
	R862	Kickstarter case stud nut $\frac{1}{4}''$ Whit.	5
	R863	Kickstarter case stud nut $\frac{5}{16}''$ Whit.	4
352	R864	Kickstarter case cover filler cap	1
331	R865	Mainshaft nut (clutch end)	1
418	R866	Mainshaft nut (k/s end)	1
330	R867	Mainshaft nut lock washer (clutch end)	1
	R868	Mainshaft nut plain washer (clutch end)	1
395	R869	Mainshaft bearing washer (k/s end)	1
390	R870	Mainshaft bearing retaining ring (k/s end)	1
342	R871	Mainshaft bearing (17 x 40 x 12mm.)	1
425	R872	Mainshaft (standard gearbox)	1
425	R873	Mainshaft (trials low ratio only)	1
322	R874	Driving sprocket 20T $\frac{1}{2}'' \times 305$ std. GB only	1
322	R875	Driving sprocket 16T $\frac{5}{8}'' \times \frac{3}{8}''$ trials and low ratio	1
393	R876	Driving sprocket spacing collar	1
391	R877	Bearing retaining ring	1
397	R878	Bearing gland washer	1
392	R879	Bearing locating split ring	1
405	R880	Bearing rubber gland	1
	R881	Packing washer (driving sprocket)	1
323	R882	Driving gear nut	1
396	R883	Driving gear nut lock washer	1
426	R884	Driving gear bush	1
343	R885	Driving gear bearing 1 $\frac{9}{32}'' \times 62\text{mm.} \times 16\text{mm.}$	1
427	R886	Driving gear with bush 30T Std.	1
427	R887	Driving gear with bush 32T (trials and low ratio)	1
428	R888	Mainshaft sliding gear 23-18 std. and low ratio	1
429	R889	3rd gear mainshaft with bush 27T std.	1
429	R890	3rd gear mainshaft with bush 29T trials and low ratio	1
412	R891	Layshaft small gear 20T std.	1
412	R892	Layshaft small gear 18T trials and low ratio	1
416	R893	2nd gear layshaft 27T std. and low ratio	1
414	R894	Layshaft clutch dog std. and low ratio	1
422	R895	1st gear layshaft 32T std. and low ratio	1
413	R896	3rd gear layshaft 23T std.	1
413	R897	3rd gear layshaft 21T trials and low ratio	1
411	R898	Layshaft spindle with bushes std. and low	1
	R899	Layshaft spindle bush with collar	1



# GEAR BOX

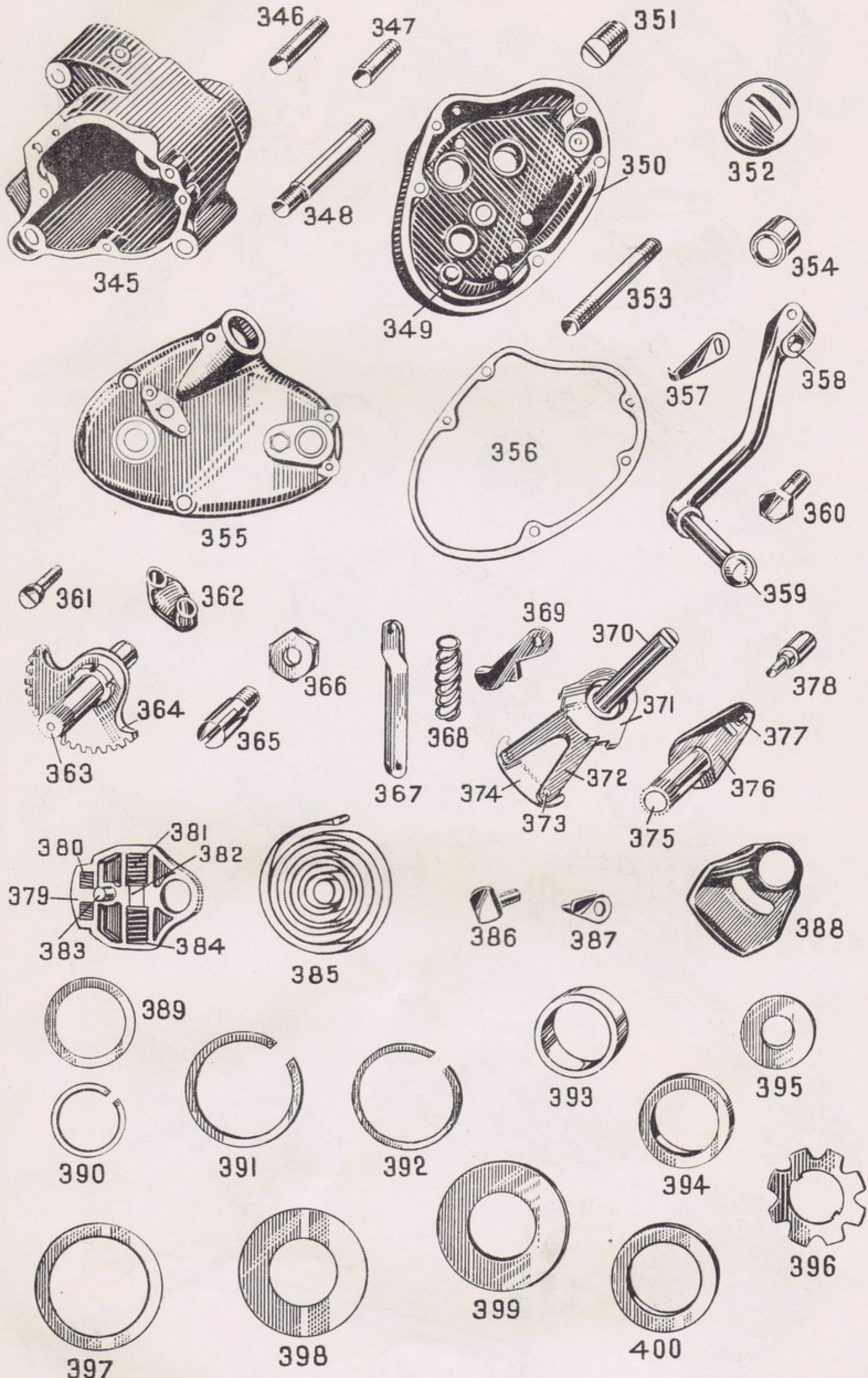

NOT TO SCALE



Order  
on this  
number

DESCRIPTION

**M75 GEARBOX 4 SPEED**—Continued

Illus. No.	Part No.	DESCRIPTION	No. Per Mach
	R900	Layshaft cover washer ... ..	1
	R901	Layshaft bush glut ... ..	1
	R902	3rd gear mainshaft bush ... ..	1
358	R903	Kickstarter lever (fixed pedal type) ... ..	1
359	R904	Kickstarter lever pedal (fixed type) ... ..	1
360	R905	Kickstarter lever pinch bolt ... ..	1
	R906	Kickstarter lever pinch bolt nut ... ..	1
	R907	Kickstarter lever pinch bolt nut washer spring ... ..	1
	R908	Kickstarter lever (folding pedal type) ... ..	1
	R909	Kickstarter lever pedal (folding type) ... ..	1
	R910	Kickstarter lever folding pedal washer ... ..	1
	R911	Kickstarter lever folding pedal washer (spring) ... ..	1
	R912	Kickstarter lever folding pedal nut ... ..	1
424	R913	Kickstarter ratchet pinion ... ..	1
423	R914	Kickstarter ratchet pinion bush ... ..	1
415	R915	Kickstarter ratchet pinion spring ... ..	1
419	R916	Kickstarter driving ratchet ... ..	1
364	R917	Kickstarter quadrant ... ..	1
363	R918	Kickstarter spindle ... ..	1
	R919	Kickstarter spindle bush (inner) ... ..	1
	R920	Kickstarter spindle bush (outer) ... ..	1
385	R921	Kickstarter spring ... ..	1
	R922	Kickstarter spring pin (fitted in K.S. case cover) ... ..	1
354	R923	Kickstarter stop peg rubber ... ..	1
349	R924	Kickstarter stop peg ... ..	1
400	R925	Felt oil seal fitted against K.S. bush ... ..	1
	R926	Oil seal retaining washer for above seal ... ..	1
402	R927	Camshaft ... ..	1
401	R928	Camshaft rollers (set of 12) ... ..	12
	R929	Camshaft bush (gearbox shell) ... ..	1
	R930	Camshaft cover washer for above ... ..	1
	R931	Camshaft bush (K.S. case) ... ..	1
406	R932	Operating fork (layshaft) ... ..	1
403	R933	Operating fork (mainshaft) ... ..	1
407	R934	Operating fork peg ... ..	2
	R935	Operating fork peg cotter pin ... ..	2
369	R936	Gearbox pawl ... ..	1
378	R937	Gearbox pawl bearing ... ..	1
	R938	Gearbox pawl bearing screw nut ... ..	1
368	R939	Gearbox pawl spring ... ..	1
351	R940	Pawl spring plug ... ..	1
372	R941	Footchange gear sector ... ..	1
374	R942	Footchange gear sector quadrant ... ..	1
373	R943	Footchange gear sector rivet $\frac{3}{16}$ " ... ..	2
	R944	Footchange ratchet rivet $\frac{1}{4}$ " ... ..	1
370	R945	Sector spindle ... ..	1
375	R946	Sector spindle bush ... ..	1
	R947	Sector spindle nut $\frac{3}{8}$ " ... ..	1
371	R948	Footchange ratchet ... ..	1
	R949	Footchange ratchet sleeve ... ..	1
376	R950	Footchange control quadrant ... ..	1
404	R951	Footchange pawl ... ..	1



GEAR BOX

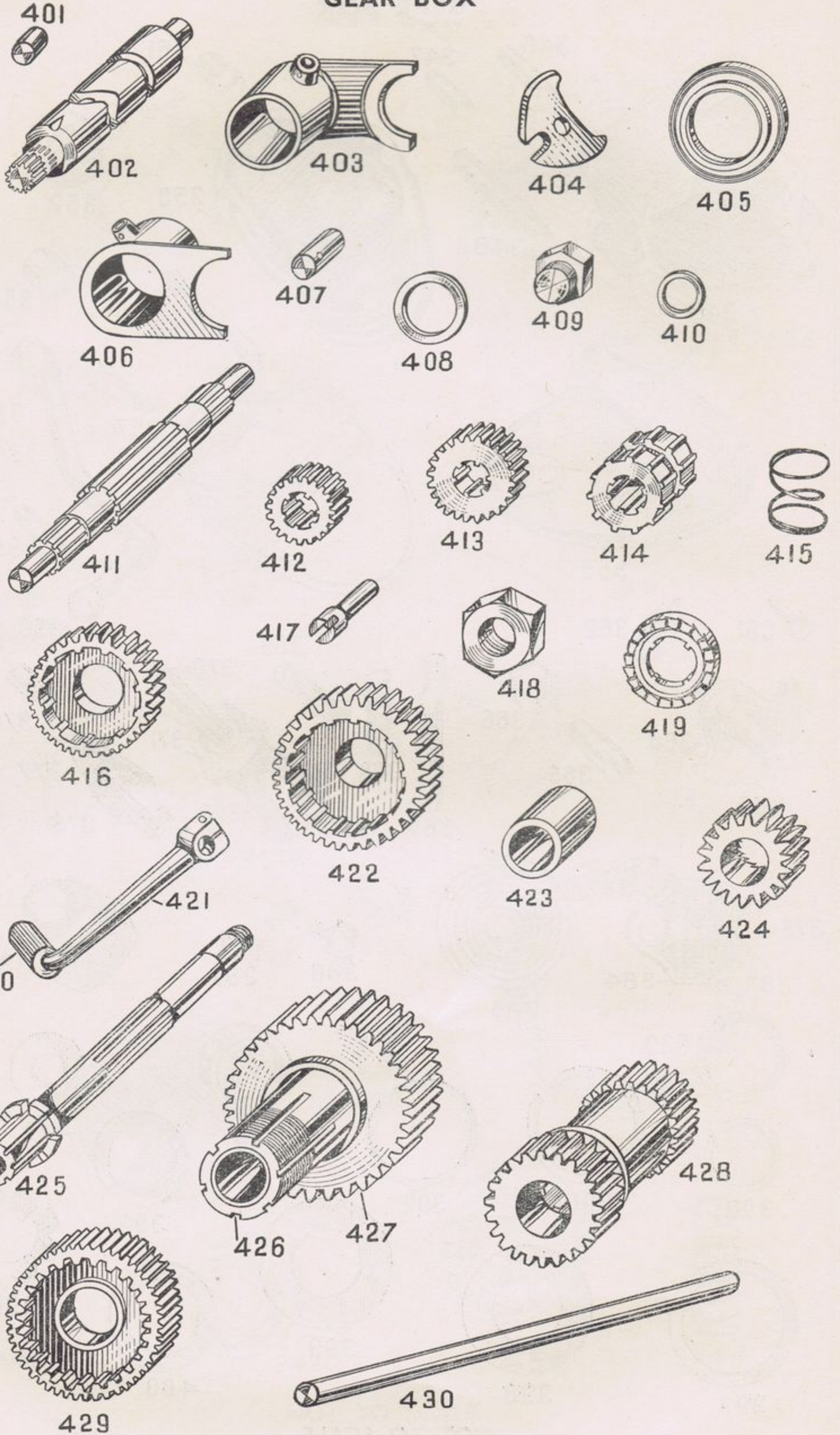

NOT TO SCALE

BARNSTORMERS.CO.NZ



Order  
on this  
number

DESCRIPTION

No.  
Per  
Mach

Illus. No.	Part No.	DESCRIPTION	No. Per Mach
		<b>M75 GEAR BOX 4 SPEED—Continued</b>	
377	R952	Footchange pawl operating peg ... ..	1
384	R953	Footchange spring box ... ..	1
388	R954	Footchange spring box cover ... ..	1
381	R955	Footchange main spring ... ..	2
382	R956	Footchange main spring plate ... ..	2
380	R957	Footchange pawl spring ... ..	2
379	R958	Footchange pawl spring plate ... ..	2
	R959	Footchange control bush ... ..	1
	R960	Footchange control bush bolt ... ..	1
421	R961	Footchange lever (bare) ... ..	1
360	R962	Footchange lever bolt ... ..	1
	R963	Footchange lever bolt nut ... ..	1
	R964	Footchange lever bolt washer ... ..	1
357	R965	Neutral indicator (moveable) ... ..	1
387	R966	Neutral indicator (fixed) ... ..	1
386	R967	Sector spindle screw ... ..	1
420	R968	Footchange lever rubber ... ..	1
	R969	Footchange lever rubber friction pin ... ..	1
	R970	Sector spindle cover washer ... ..	1
408	R971	Oil seal felt fitted in ratchet sleeve ... ..	1
408	R972	Oil seal felt fitted against F.C. bush ... ..	1
324	R973	Clutch case (4 plate) ... ..	1
338	R974	Clutch spring plate ... ..	1
336	R975	Clutch spring plate thrust cup ... ..	1
344	R976	Clutch spring ... ..	4
339	R977	Clutch spring cup ... ..	4
341	R978	Clutch spring adjusting nut ... ..	4
335	R979	Clutch spring stud ... ..	4
329	R980	Clutch centre (4 plate) ... ..	1
334	R981	Clutch plain steel plate ... ..	4
333	R982	Clutch plain steel back plate $\frac{1}{8}$ " thick ... ..	1
340	R983	Clutch friction plate lined with neoprene ... ..	4
325	R984	Chainwheel 40 tooth $\frac{1}{2}$ " x 305 ... ..	1
	R985	Chainwheel rivet ... ..	8
394	R986	Roller race ... ..	1
326	R987	Clutch rollers (per set of 24) ... ..	24
398	R988	Roller race washer (thin) ... ..	1
399	R989	Roller race washer (thick) ... ..	1
430	R990	Clutch operating rod $9\frac{7}{8}$ " ... ..	1
417	R991	Clutch operating plunger ... ..	1
367	R992	Clutch operating lever ... ..	1
	R993	Clutch operating lever pin ... ..	1
365	R994	Clutch operating lever fork ... ..	1
366	R995	Clutch operating lever adj. sleeve ... ..	1
362	R996	Clutch operating lever adj. sleeve cap ... ..	1
361	R997	Clutch operating lever adj. sleeve screw ... ..	1
86	R998	Clutch lever ball $\frac{1}{4}$ " ... ..	1

**FRONT WHEEL & BRAKE PARTS**

R1051	Front wheel complete M.75 ... ..	1
R1052	Front wheel complete M.65 ... ..	1

BARNSTORMERS.CO.NZ



Order  
on this  
number

DESCRIPTION

Illus. No.	Part No.	DESCRIPTION	No. Per Mach
		<b>FRONT WHEEL &amp; BRAKE PARTS—Continued</b>	
	RI053	Front hub complete	1
431	RI054	Front rim (chromium) 19" x 2½" Mod. 75	1
431	RI055	Front rim (black) 19" x 2½" Mod. 65	1
433	RI056	Spoke 10 gauge 6⅛" long	10
433	RI057	Spoke 10 gauge 6⅝" long	10
433	RI058	Spoke 10 gauge 8⅞" long	20
432	RI059	Nipple 10 gauge	40
434	RI060	Hub shell with brake drum	1
452	RI061	Brake shoes complete with liners	1 pr
451	RI062	Brake liners drilled complete with rivets	1 pr
435	RI063	Side plate with cam bush, fulcrum pin and anchor arm	1
454	RI064	Brake cam with nut and washer	1
438	RI065	Brake cam lever	1
436	RI066	Brake cam lever yoke	1
437	RI067	Brake cam lever yoke pin	1
453	RI068	Brake shoe spring	2
	RI069	Oil hole cover for cam bearing	1
	RI070	Hub lubricator	1
442	RI071	Wheel spindle	1
445	RI072	Ball journal	2
447	RI073	Felt washer	2
446	RI074	Distance piece 1⅛" x ¼"	2
448	RI075	Distance washer 1⅛" x ⅛"	2
449	RI076	Large bearing washer 1⅝" dia. x 3/32"	2
450	RI077	Dust cover	2
443	RI078	Lock nut 9/32" wide L.H.	1
444	RI079	Spindle nut long L.H.	1
441	RI080	Lock nut ⅜" wide R.H.	1
440	RI081	Brake plate distance collar ¾" R.H.	1
448	RI082	Brake plate distance washer 1⅛" x 1/32" R.H.	1
439	RI083	Spindle nut short R.H.	2

**REAR WHEEL & BRAKE PARTS**

	RI101	Rear wheel complete M.75	1
	RI102	Rear wheel complete M.65	1
	RI103	Rear hub complete	1
431	RI104	Rear wheel rim (chromium) 19" x 2½" Mod. 75	1
431	RI105	Rear wheel rim (black) 19" x 2½" Mod. 65	1
433	RI106	Spoke 9 gauge 6¾" long	10
433	RI107	Spoke 9 gauge 6⅛" long	10
433	RI108	Spoke 9 gauge 8⅞" long	10
433	RI109	Spoke 9 gauge 8⅛" long	10
432	RI110	Nipple 9 gauge	40
458	RI111	Hub shell with brake drum	1
452	RI112	Brake shoes complete with liners	1 pr
451	RI113	Brake liners complete with rivets	1 pr
460	RI114	Side plate with cam bush, fulcrum pin and anchor arm	1
454	RI115	Brake cam with nut and washer	1
461	RI116	Brake cam lever	1
453	RI117	Brake shoe spring	2



WHEELS, HUBS, BRAKES

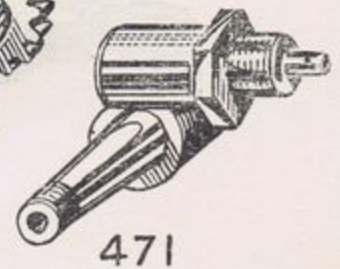
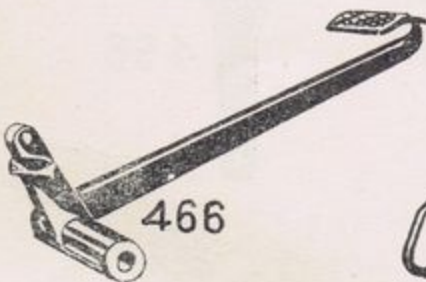
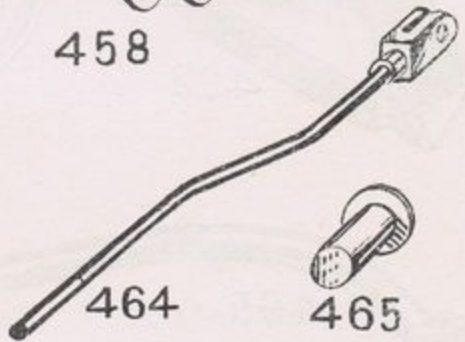
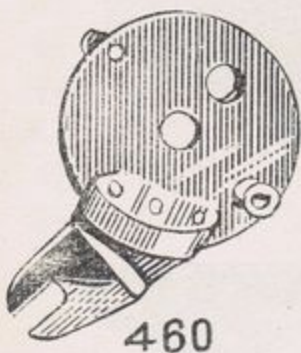
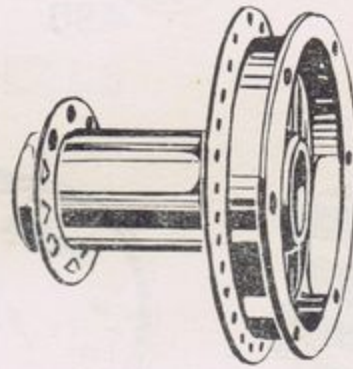
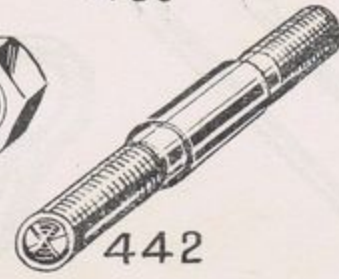
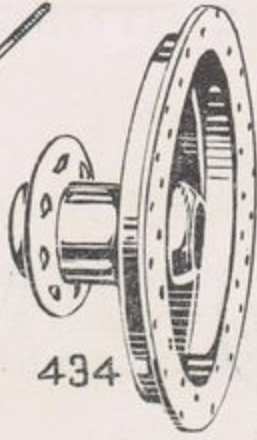
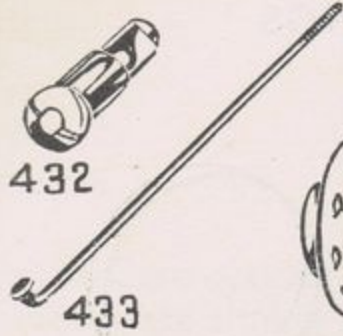

NOT TO SCALE



Order on this number	Part No.	DESCRIPTION	No. Per Mach
		<b>REAR WHEEL &amp; BRAKE PARTS—Continued</b>	
	R1118	Oil hole cover for cam bearing ... ..	1
	R1119	Hub lubricator ... ..	1
456	R1120	Wheel spindle ... ..	1
445	R1121	Ball journal ... ..	2
447	R1122	Felt washer ... ..	2
446	R1123	Distance piece $1\frac{1}{8}'' \times \frac{1}{4}''$ ... ..	2
448	R1124	Distance washer $1\frac{1}{16}'' \times \frac{1}{16}''$ ... ..	2
449	R1125	Large bearing washer $1\frac{5}{8}'' \times 3/32''$ ... ..	2
450	R1126	Dust cover ... ..	2
441	R1127	Lock nut $\frac{1}{2}''$ wide L.H. ... ..	1
440	R1128	Distance collar $\frac{3}{4}''$ wide L.H. ... ..	1
443	R1129	Lock nut $\frac{1}{4}''$ wide R.H. ... ..	1
457	R1130	Chain adjusting cam ... ..	2
455	R1131	Spindle nut ... ..	2
132	R1132	Rear wheel sprocket 50T ... ..	1
	R1133	Rear wheel sprocket bolt ... ..	6
	R1134	Rear wheel sprocket nut ... ..	6
	R1135	Rear wheel sprocket spring washer ... ..	6
466	R1151	Brake pedal ... ..	1
464	R1152	Brake rod with end ... ..	1
467	R1153	Brake pedal spring ... ..	1
465	R1154	Brake pin $\frac{1}{4}''$ ... ..	1
	R1155	$\frac{1}{16}''$ Cotter pin ... ..	1
468	R1156	Brake pedal nut ... ..	1
	R1157	Screw for brake pedal nut ... ..	1
462	R1158	Brake rod roller ... ..	1
463	R1159	Brake rod adjusting nut ... ..	1
	R1160	$\frac{3}{8}''$ Flat washer ... ..	1
	R95	$\frac{3}{8}''$ spring washer ... ..	2
459	R1161	Speedo drive plug ... ..	1
	R1171	Front tyre (ribbed) 19'' x .325 ... ..	1
	R1172	Rear tyre 19'' x .325 ... ..	1
	R1173	Inner tube ... ..	2
274	R1174	Schrader valve core ... ..	2
	R1175	Schrader valve cap ... ..	2
	R1176	Rim band ... ..	2

### SPEEDOMETER & PARTS

	R1181	Speedometer complete ... ..	1
493	R1182	Speedometer head ... ..	1
495	R1183	Speedometer cable complete ... ..	1
471	R1184	Speedometer gear box complete ... ..	1
469	R1185	Speedometer gear ring 34139/1 44T ... ..	1
470	R1186	Speedometer pinion 14T ... ..	1
496	R1187	Speedometer bracket ... ..	1
	R1188	Speedometer light complete ... ..	1
	R1189	Speedometer bulb only ... ..	1
	R1190	Speedometer fixing nuts $\frac{1}{4}''$ ... ..	2



Order  
on this  
number

DESCRIPTION

No.  
Per  
Mach

Illus.  
No.

Part  
No.

**SPEEDOMETER & PARTS**—Continued

	R1191	Speedometer spring washers $\frac{1}{4}$ "	...	...	...	...	2
	R246	Speedometer bracket fixing bolt $\frac{5}{16}$ " x $\frac{7}{8}$ "	...	...	...	...	2
	R486	Speedometer bracket fixing flat washers $\frac{5}{16}$ "	...	...	...	...	2
	R487	Speedometer bracket fixing spring washer $\frac{5}{16}$ "	...	...	...	...	2

**CHAINS**

	R1211	Primary chain $\frac{1}{2}$ " x .305" 64 links Mod. 65	...	...	...	...	1
	R1212	Primary chain $\frac{1}{2}$ " x .305" 68 links Mod. 75	...	...	...	...	1
	R1213	Driving chain $\frac{1}{2}$ " x .305" 108 links	...	...	...	...	1
	R1214	Double cranked link	...	...	...	...	2
	R1215	Spring clip links	...	...	...	...	2
	R1216	Spring clip spring only	...	...	...	...	2

**HANDLEBAR WITH CONTROLS & WIRES**

	R1231	Handlebar comp. with control levers and wires	...	...	...	...	1
209	R1232	Handlebar only	...	...	...	...	1
	R1233	Twist grip complete	...	...	...	...	1
212	R1234	Twist grip sleeve and rotor	...	...	...	...	1
213	R1235	Twist grip half clip with friction spring	...	...	...	...	1
217	R1236	Twist grip half clip plain	...	...	...	...	1
214	R1237	Twist grip friction spring	...	...	...	...	1
215	R1238	Twist grip adjusting screw and nut	...	...	...	...	1
	R1239	Twist grip cable stop	...	...	...	...	1
216	R1240	Twist grip clamp screws	...	...	...	...	2
211	R1241	Twist grip rubber	...	...	...	...	1
210	R1242	Dummy grip rubber	...	...	...	...	1
	R1243	Front brake and air lever complete	...	...	...	...	1
	R1244	Clutch lever complete	...	...	...	...	1
	R1245	Valve lifter lever complete	...	...	...	...	1
232	R1246	Front brake lever only	...	...	...	...	1
231	R1247	Front brake lever body	...	...	...	...	1
227	R1248	Air lever only	...	...	...	...	1
228	R1249	Air lever body	...	...	...	...	1
226	R1250	Air lever friction washer	...	...	...	...	1
225	R1251	Air lever cap	...	...	...	...	1
224	R1252	Air lever cap screw	...	...	...	...	1
229	R1253	Front brake lever screw (shouldered)	...	...	...	...	1
230	R1254	Front brake lever screw (plain)	...	...	...	...	1
223	R1255	Front brake or clutch lever fulcrum screw	...	...	...	...	2
	R1256	Front brake or clutch lever fulcrum screw nut	...	...	...	...	2
221	R1257	Clutch lever...	...	...	...	...	1
222	R1258	Clutch lever body	...	...	...	...	1
219	R1259	Clutch or valve lifter body clip	...	...	...	...	2
	R1260	Clutch or valve lifter body screw	...	...	...	...	4
220	R1261	Valve lifter lever	...	...	...	...	1
218	R1262	Valve lifter lever body	...	...	...	...	1
	R1263	Valve lifter lever fulcrum screw and nut	...	...	...	...	1



# HANDLEBAR, TANK & FITTINGS



NOT TO SCALE

BARNSTORMERS.CO.NZ



Order  
on this  
number

DESCRIPTION

No.  
Per  
Mach

Illus.  
No.

Part  
No.

**CONTROL WIRES**

	R1264	Throttle outer cable with caps	...	...	...	...	...	1
	R1265	Throttle inner wire with nipples	...	...	...	...	...	1
	R1266	Front brake outer cable with caps	...	...	...	...	...	1
	R1267	Front brake inner wire with nipples	...	...	...	...	...	1
	R1268	Front brake adjusting screw and locknut	...	...	...	...	...	1
	R1269	Air outer cable with caps	...	...	...	...	...	1
	R1270	Air inner wire with nipples	...	...	...	...	...	1
	R1271	Clutch outer cable with caps	...	...	...	...	...	1
	R1272	Clutch inner wire with nipples	...	...	...	...	...	1
	R1273	Clutch wire adjusting screw and locknut	...	...	...	...	...	1
	R1274	Valve lifter outer cable	...	...	...	...	...	1
	R1275	Valve lifter inner wire	...	...	...	...	...	1
	R1276	Valve lifter wire adj. screw and locknut	...	...	...	...	...	1
	R1277	Nipple (throttle or air) handlebar end	...	...	...	...	...	2
	R1278	Nipple (throttle or air) carburetter end	...	...	...	...	...	2
	R1279	Nipple (clutch or brake) handlebar end	...	...	...	...	...	2
	R1280	Nipple (clutch) gear box end	...	...	...	...	...	1
	R1281	Nipple (brake) wheel end	...	...	...	...	...	1
	R1282	Nipple (valve lifter) handlebar end	...	...	...	...	...	1
	R1283	Nipple (valve lifter) engine end	...	...	...	...	...	1
244	R1284	Front brake cable clip	...	...	...	...	...	1
167	R1285	Valve lifter stop	...	...	...	...	...	1

**HEADLAMPS AND PARTS**

MODEL 65<sup>7</sup> only

	R1301	Headlamp complete with wires and dipper switch	...	...	...	...	...	1
	R1302	Headlamp complete less wires	...	...	...	...	...	1
	R1303	Panel complete with switch and ammeter	...	...	...	...	...	1
480	R1304	Ammeter	...	...	...	...	...	1
	R1305	Warning bulbholder with insulating disc	...	...	...	...	...	1
	R1306	Warning bulb	...	...	...	...	...	1
	R1307	Switch complete	...	...	...	...	...	1
	R1308	Switch Rubber ring	...	...	...	...	...	1
	R1309	„ Rotor	...	...	...	...	...	1
	R1310	„ contact spring	...	...	...	...	...	1
	R1311	„ „ „ guide	...	...	...	...	...	1
	R1312	„ „ roller	...	...	...	...	...	1
479	R1313	„ lever	...	...	...	...	...	1
	R1314	„ „ rubber washer	...	...	...	...	...	1
	R1315	„ terminal screws	...	...	...	...	...	1
	R1316	„ fixing bridge	...	...	...	...	...	1
	R1317	„ „ „ screw	...	...	...	...	...	2
	R1318	Ignition key	...	...	...	...	...	1
	R1319	Bulb holder clip	...	...	...	...	...	1
	R1320	„ „ „ screw	...	...	...	...	...	1
	R1321	Lighting cables complete	...	...	...	...	...	1 set

BARNSTORMERS.CO.NZ



Order  
on this  
number

DESCRIPTION

Illus. No.	Part No.	DESCRIPTION	No. Per Mach	
<b>HEADLAMPS &amp; PARTS—Continued</b>				
MODEL 75 only				
480	RI322	Headlamp complete with wires and dipper switch ... ..	1	
	RI323	Headlamp complete, less wires ... ..	1	
	RI324	Panel complete with ammeter and switch ... ..	1	
	RI325	Ammeter ... ..	1	
	RI326	„ terminal pillar ... ..	2	
	RI327	„ „ grub screw ... ..	2	
	RI328	„ „ fibre bridge, top ... ..	1	
	RI329	„ „ „ „ bottom ... ..	1	
	RI330	Switch complete ... ..	1	
	RI331	„ rotor ... ..	1	
RI332	„ „ contact spring ... ..	1		
MODEL 75 only				
479	RI333	Switch contact spring guide ... ..	1	
	RI334	„ „ roller ... ..	1	
	RI335	„ lever ... ..	1	
	RI336	„ „ screw ... ..	1	
	RI337	„ fixing spring wire ... ..	1	
	RI338	Lighting cables complete ... ..	1 set	
MODELS 65 and 75				
475	RI339	Rim assembly with glass ... ..	1	
	RI340	„ only ... ..	1	
473	RI341	„ fixing hook ... ..	1	
	RI342	„ „ „ wire spring ... ..	1	
	RI343	Headlamp glass ... ..	1	
474	RI344	Fixing wire for glass ... ..	3	
474	RI345	Rubber bead ... ..	1	
476	RI346	Panel only ... ..	1	
478	RI347	„ fixing screws ... ..	3	
472	RI348	Ammeter rubber ring ... ..	1	
	RI349	„ terminal nut ... ..	2	
	RI350	„ small fibre washer ... ..	2	
	RI351	Reflector ... ..	1	
477	RI352	Bulb holder, double contact ... ..	1	
	RI353	Interior bulb holder, pilot ... ..	1	
	RI354	Headlamp fixing screw ... ..	2	
	RI355	„ „ „ washer ... ..	2	
	482	RI356	„ bracket, R.H. top ... ..	1
	481	RI357	„ „ L.H. top ... ..	1
484	RI358	„ „ R.H. bottom ... ..	1	
483	RI359	„ „ L.H. bottom ... ..	1	
489	RI360	Dipper switch complete with wire ... ..	1	
	RI361	„ „ less wire ... ..	1	
	RI362	„ „ wire ... ..	1	
	RI363	„ „ cap ... ..	1	
	RI364	„ „ clip with bolt and collars ... ..	1	
	RI365	Rubber sheath for cables ... ..	4	



# ELECTRIC FITTINGS



472



473



474



475

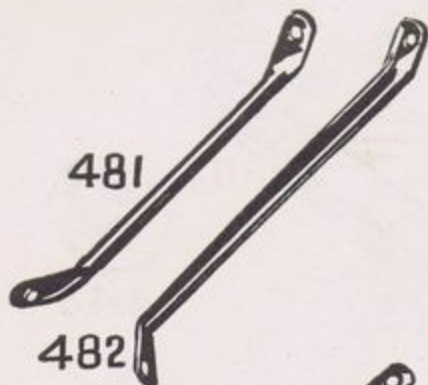

481

482



477



478



476



479



480

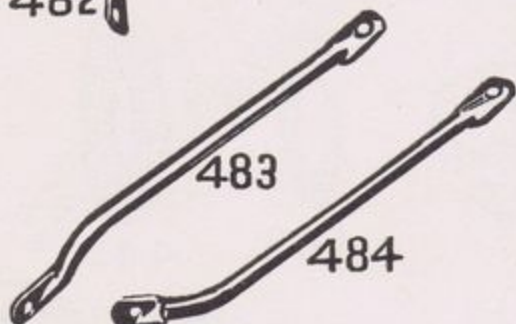

483

484



485

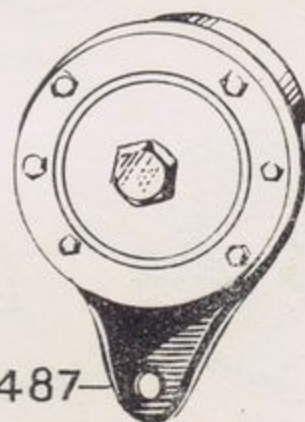

488



489



490



491

487



492



493

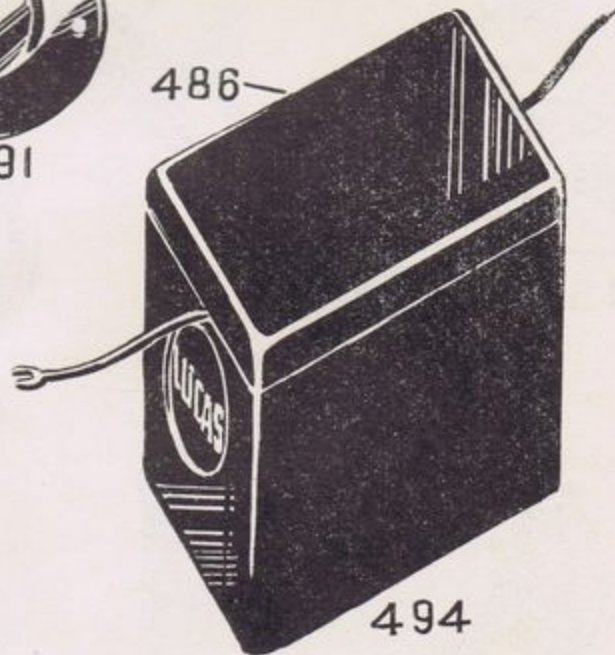

486

494



495



498

497



496



Order  
on this  
number

DESCRIPTION

Illus.  
No.

Part  
No.

**HEADLAMPS AND PARTS**—Continued

No.  
Per  
Mach

MODELS 65 and 75

	R1366	Terminals, large ring	...	...	...	...	...	...	1
	R1367	„ small ring	...	...	...	...	...	...	3
	R1368	„ tubular	...	...	...	...	...	...	3
	R1369	„ flat	...	...	...	...	...	...	2
	R1370	$\frac{5}{16}$ " x $\frac{3}{4}$ " H.H. screw, lamp bracket	...	...	...	...	...	...	2
	R247	$\frac{5}{16}$ " spring washer	...	...	...	...	...	...	2
	R486	$\frac{5}{16}$ " flat washer	...	...	...	...	...	...	2
	R1371	Headlamp bulb, main	...	...	...	...	...	...	1
	R1372	„ „ pilot	...	...	...	...	...	...	1
	R1373	Tail lamp complete	...	...	...	...	...	...	1
491	R1374	„ „ flange assembly	...	...	...	...	...	...	1
490	R1375	„ „ cover	...	...	...	...	...	...	1
	R1376	„ „ spring	...	...	...	...	...	...	1
	R1377	„ „ insulating washer	...	...	...	...	...	...	2
	R1378	„ „ celluloid panel	...	...	...	...	...	...	1
	R1379	„ „ glass	...	...	...	...	...	...	1
	R1380	„ „ „ mount	...	...	...	...	...	...	1
	R1381a	„ „ fixing screw and nut	...	...	...	...	...	...	3
	R1382a	Wire connection, complete with rubber sleeve	...	...	...	...	...	...	1
	R1372	Tail lamp bulb	...	...	...	...	...	...	1

**IGNITION COIL**

MODEL 65 only

497	R1381	Coil complete	...	...	...	...	...	...	1
173	R1382	„ fixing clip	...	...	...	...	...	...	1
172	R1383	„ „ „ distance plate	...	...	...	...	...	...	1
	R1384	$\frac{1}{4}$ " x $1\frac{1}{4}$ " H.H. Screw	...	...	...	...	...	...	2
	R436	$\frac{1}{4}$ " Spring washer	...	...	...	...	...	...	2
	R117	$\frac{1}{4}$ " Nut	...	...	...	...	...	...	2
	R1385	Coil terminal nut	...	...	...	...	...	...	2
	R1386	„ „ „ washer	...	...	...	...	...	...	2
	R1387	H.T. wire with terminal	...	...	...	...	...	...	1
	R1388	H.T. terminal (plug end)	...	...	...	...	...	...	1
	R1389	H.T. „ (coil end)	...	...	...	...	...	...	1
498	R1390	Bakelite connector screw	...	...	...	...	...	...	1

**DISTRIBUTOR**

MODEL 65 only

	R1391	Distributor	...	...	...	...	...	...	1
	R1392	„ plate assembly	...	...	...	...	...	...	1
	R1393	Cover	...	...	...	...	...	...	1
	R1394	Contact set	...	...	...	...	...	...	1
	R1395	Condenser	...	...	...	...	...	...	1
	R1396	Cam	...	...	...	...	...	...	1



Order on this number	Part No.	DESCRIPTION	No. Per Mach
		<b>DISTRIBUTOR—Continued</b>	
	R1397	Springs, auto, advance	2
	R1398	Weights, auto. advance	2
	R1399	Shaft and action plate	1
	R1400	Bearing bush top	1
	R1401	"    "    bottom	1
	R1402	Cover clip	2
	R1403	"    "    pivot pin	2
	R1404	Plate assembly screw, $\frac{1}{4}$ " x $1\frac{3}{8}$ " H.H.	1
	R117	"    "    nut $\frac{1}{4}$ "	1
	R436	"    "    spring washer $\frac{1}{4}$ "	1
	R1405	"    "    fixing screw	1
106	R1406	Distributor adapter	1

## DISTRIBUTOR

MODEL 65 only

	R263	Distributor fixing screws, $\frac{1}{4}$ " x $\frac{5}{8}$ " H.H.	3
102	R1407	"    grub screw	1
108	R1408	"    gear wheel	1
	R1409	"    "    split pin $3/32$ " x $1\frac{1}{4}$ "	1

## DYNAMO

MODEL 65 and 75

	R1421	Dynamo complete	1
	R1422	"    brush set	1
	R1423	"    bracket C.E.	1
	R1424	"    bearing bush C.E.	1
	R1425	"    spring set, brush tension	1
	R1426	"    cover C.E.	1
	R1427	"    bearing, D.E.	1
	R1428	"    bracket, D.E.	1
	R1429	"    insulated plate, with brush holders	1
	R1430	"    armature	1
	R1431	"    field coil	1
	R1432	"    cover band	1
100	R1433	"    fixing stud 2B.A. x $2\frac{3}{8}$ "	1
	R1434	"    "    "    nut	1
101	R1435	"    gasket, D.E.	1
7	R1436	"    strap	1
9	R1437	"    "    plate	1
8	R1438	"    "    fixing screws $\frac{3}{4}$ " x $\frac{9}{16}$ " (front)	1
5	R1439	"    "    "    "    "    (rear)	1
6	R1439A	"    "    bobbin	1



Illus. No.	Part No.	DESCRIPTION	No. Per Mach
<b>BATTERY</b>			
494	RI440	Battery 6-volt	1
486	RI441	„ lid	1
207	RI442	„ platform	1
208	RI443	„ top plate	1
205	RI444	„ bolt with knurled nut	2
206	RI445	„ stud	2

## MAGNETO

### MODEL 75 only

	RI451	Magneto complete with auto advance	1
	RI452	Magneto complete less auto advance	1
	RI453	Magneto pick-up assembly	1
	RI454	Magneto contact breaker cover	1
	RI455	Magneto contact breaker assembly	1
	RI456	Magneto contact set	1
	RI457	Magneto contact spring set	1
	RI468	Magneto brush and spring assembly	1
	RI469	Magneto cam	1
	RI470	Magneto plate assembly, C.E. end	1
	RI471	Magneto spindle nut	1
	RI472	Magneto armature assembly	1
	RI473	Magneto slip ring	1
	RI474	Magneto bearing complete	1
	RI475	Magneto brush spring and holder	1
109	RI476	Magneto auto advance unit complete	1
	R574	Magneto fixing screws $\frac{3}{4}$ " x $\frac{7}{8}$ " H.H.	3
	RI45	Magneto fixing screw flat washers	3
	RI477	High tension wire with plug terminal	1

## VOLTAGE CONTROL UNIT

### MODELS 65 and 75

492	RI478	Control box complete	1
174	RI479	Control box clip	1
	R607	Control box screw $\frac{1}{4}$ " x $1\frac{1}{8}$ " H.H.	2
	RI17	Control box nut $\frac{1}{4}$ "	2
	RI480	Control box distance piece	2

## HORN

### MODELS 65 and 75

488	RI481	Horn complete	1
485	RI482	Horn switch, complete	1
487	RI483	Horn bracket	1
	RI484	Horn bracket screw	2



Order  
on this  
number

DESCRIPTION

Illus.  
No.

Part  
No.

No.  
Per  
Mach

**TOOLS & ACCESSORIES**

R1491	Toolroll with tools	...	...	...	...	...	...	1
R1492	Toolroll only	...	...	...	...	...	...	1
R1493	Grease gun	...	...	...	...	...	...	1
R1494	Pliers	...	...	...	...	...	...	1
R1495	Screwdriver	...	...	...	...	...	...	1
R1496	$\frac{1}{4}$ " x $\frac{5}{16}$ " Whitworth spanner	...	...	...	...	...	...	1
R1497	$\frac{1}{8}$ " x $\frac{3}{16}$ " Whitworth spanner	...	...	...	...	...	...	1
R1498	$\frac{3}{8}$ " single ended spanner	...	...	...	...	...	...	1
R1499	Tappet spanner	...	...	...	...	...	...	1
R1500	Double ended box key	...	...	...	...	...	...	1
R1501	Large single ended box key	...	...	...	...	...	...	1
R1502	Small single ended box key	...	...	...	...	...	...	1
R1503	Inflator	...	...	...	...	...	...	1
R1504	Inflator connection	...	...	...	...	...	...	1
R1505	Panther valve remover	...	...	...	...	...	...	1
R1506	Exhaust nut spanner	...	...	...	...	...	...	1
R1507	Valve grinding tool	...	...	...	...	...	...	1
R1508	Chain rivet extractor	...	...	...	...	...	...	1
R1509	Licence holder complete	...	...	...	...	...	...	1
R1510	Pillion cushion	...	...	...	...	...	...	1
R1511	Panther button hole badge	...	...	...	...	...	...	1
R1512	Frame head transfer (top)	...	...	...	...	...	...	1
R1513	Frame head transfer (bottom)	...	...	...	...	...	...	1
R1514	Letter transfers for number plates	...	...	...	...	...	...	9
R1515	Number transfers for number plates	...	...	...	...	...	...	9



E. T. Heron & Co., Ltd.



London and Essex.