

**RUNNING INSTRUCTIONS**  
**FOR THE**  
**LUCAS "MDB" "MAGDYNO"**  
**LIGHTING AND IGNITION SET**  
**FOR MOTOR-CYCLES**  
**1929 EQUIPMENT**



**LUCAS**

**DESIGNED AND MANUFACTURED BY**  
**JOSEPH LUCAS LIMITED, BIRMINGHAM, ENGLAND**

*Instruction Booklet No. 88.*

**RUNNING INSTRUCTIONS**  
FOR THE  
**LUCAS "MDB" "MAGDYNO"**  
**LIGHTING AND IGNITION SET**  
FOR MOTOR-CYCLES (SOLO AND SIDE-CAR)  
(1929 EQUIPMENT)

---

DESIGNED AND MANUFACTURED THROUGHOUT BY  
**JOSEPH LUCAS LIMITED,**

HEAD OFFICES AND WORKS:  
**BIRMINGHAM, ENGLAND.**

TELEGRAMS: "LUCAS, BIRMINGHAM."

TELEPHONE: NORTHERN 2201 (10 LINES)

CODES USED—ABC (5TH & 6TH EDITIONS) AND BENTLEYS.

# Running Instructions for the Lucas "Magdyno" Set

## (1929 EQUIPMENT)

THE "Magdyno," as the name suggests, consists of two units: the magneto for ignition, and the dynamo for charging the battery. For the sake of simplicity and compactness, both units are housed together, the stationary parts, the dynamo yoke, and the magneto pole laminations being cast in a common aluminium frame. Power is transmitted to the dynamo (the upper unit) by gears driven from the magneto spindle. The electro-magnetic cut-out is mounted directly on the commutator end bracket of the dynamo, thus, with the exception of the controlling switches and the battery, the "Magdyno" contains the whole of the charging and ignition system.

### THE DYNAMO.

The dynamo begins to charge the 6 volt battery at low road speed, rapidly increasing to its maximum output of 4 to 5 amperes. The regulation of the dynamo is effected by means of the well-known three-brush method. The two main brushes lie across a horizontal diameter, the positive insulated and the negative earthed to the frame of the machine, and the control brush is on the underside of the commutator bracket.

The dynamo does not require a great deal of attention, but there are a few components which should be inspected occasionally to ensure satisfactory running.

Before removing the cover for any reason, *it is necessary* to disconnect the positive lead of the battery to avoid the danger of reversing the polarity of the dynamo, or short circuiting the battery, either of which might cause serious damage.

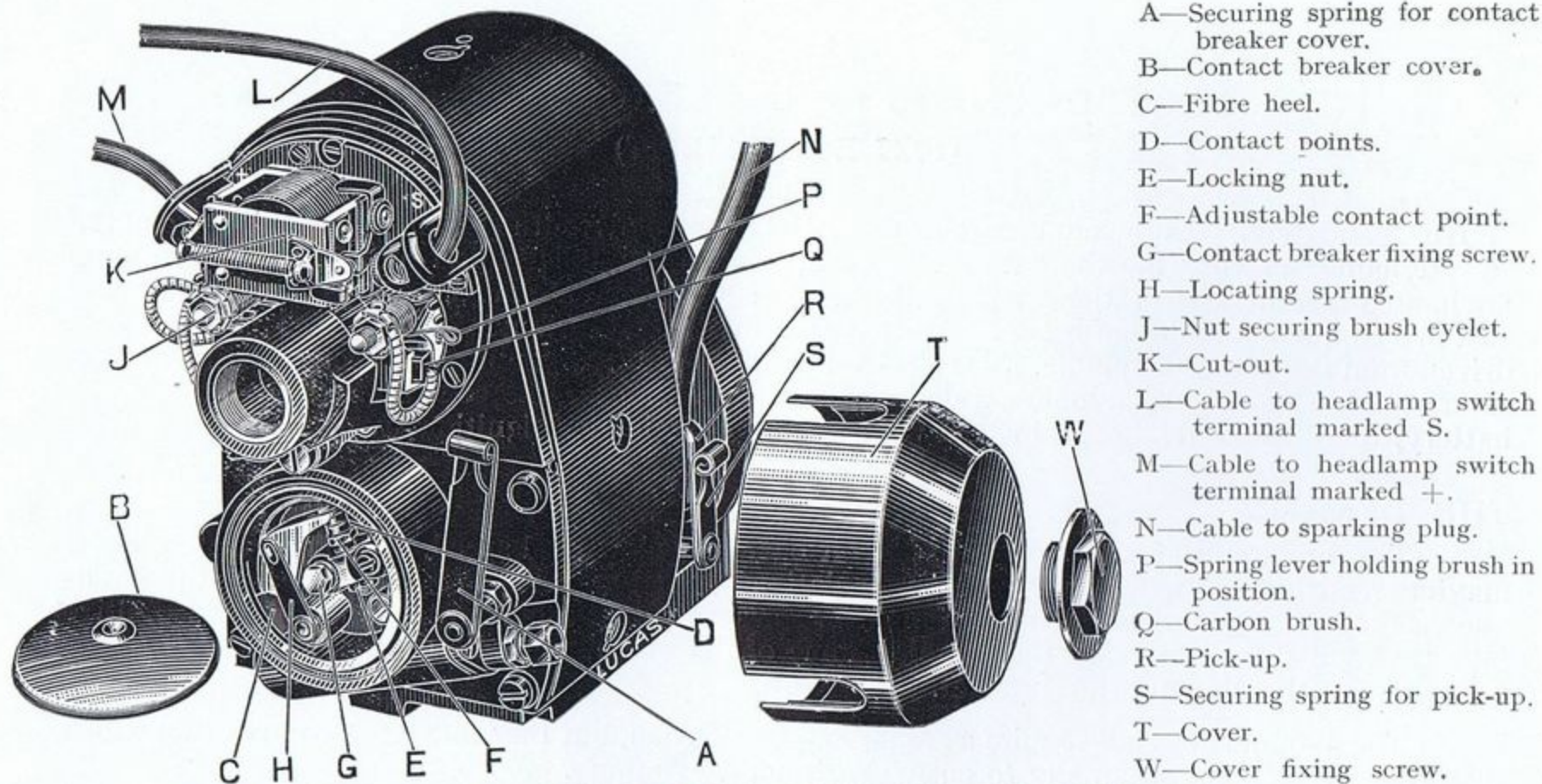

- A—Securing spring for contact breaker cover.
- B—Contact breaker cover.
- C—Fibre heel.
- D—Contact points.
- E—Locking nut.
- F—Adjustable contact point.
- G—Contact breaker fixing screw.
- H—Locating spring.
- J—Nut securing brush eyelet.
- K—Cut-out.
- L—Cable to headlamp switch terminal marked S.
- M—Cable to headlamp switch terminal marked +.
- N—Cable to sparking plug.
- P—Spring lever holding brush in position.
- Q—Carbon brush.
- R—Pick-up.
- S—Securing spring for pick-up.
- T—Cover.
- W—Cover fixing screw.

**FIG. 1. VIEW SHOWS "MAGDYNO" ARRANGED FOR DRIVING IN ANTI-CLOCKWISE DIRECTION.**

With a clockwise machine the positions of the terminals marked + and S are interchanged, and the control brush box is situated on the opposite side of the contact breaker housing.

## Brushes.

It is very important to make sure that the brushes work freely in their holders. This can be easily ascertained by holding back the spring lever and gently pulling each flexible lead, when the brush should move without the slightest suggestion of sluggishness. It should also return to its original position directly the lead is let go. When testing the brush in this way, release it gently, otherwise it may get chipped. The brushes should be clean and "bed" over the whole surface; that is, the face in contact with the commutator should appear uniformly polished. Dirty brushes may be cleaned with a cloth moistened with petrol.

If the brushes become so badly worn that it is necessary to replace them, this can easily be done as follows:—

Release the eyelet on the brush lead by unscrewing the hexagonal nut "J" (Fig. 1) on the terminal; then, holding back the spring lever "P" out of the way, withdraw the brush from its holder.

The brush springs should be inspected occasionally to see that they have sufficient tension to keep the brushes firmly pressed against the commutator when the machine is running. It is particularly necessary to keep this in mind when the brushes have been in use a long time and are very much worn down.

Owners are cautioned that it is unwise to insert brushes of a grade other than that supplied with the machine, or to change the tension springs. The arrangement provided has been made only after many years' experience, and will be found to give the best results and the longest life.

If at any time the motor cycle must be ridden with the batteries disconnected, or in any way out of service, it is essential to run with the switch in the "OFF" position.

## **Commutator.**

The surface of the commutator should be kept clean and free from oil or brush dust, etc. Should any grease or oil work its way on to the commutator through over-lubrication, it will not only cause sparking but in addition, carbon and copper dust will be collected in the grooves between the commutator segments. The best way to clean the commutator is, without disconnecting any leads, to remove from its box one of the main brushes, and, inserting a fine duster in the box, hold it, by means of a suitably shaped piece of wood, against the commutator surface, causing the armature to be rotated at the same time. If the commutator has been neglected for long periods, it may need cleaning with fine glass paper, but this is more difficult to do and should not be necessary if it has received regular attention.

## **Terminals.**

The positive dynamo terminal, marked +, and the shunt field terminal, marked S, are situated on either side of the automatic cut-out. To connect up, the cables merely have to be bared and clamped in their terminals by means of grub screws. (For wiring, see page 14).

## **Electro Magnetic Cut-out.**

The cut-out automatically closes the charging circuit, as soon as the dynamo voltage rises above that of the battery. When the dynamo voltage falls below that of the battery, the reverse action takes place, the cut-out opens and thereby prevents the battery from discharging itself through the dynamo.

The cut-out is accurately set before leaving the works, and should not be tampered with or adjusted. Should the cut-out fail to close the circuit on accelerating the engine, the cause of the damage is likely to be found elsewhere on the system ; the tables of possible faults, on pages 28 and 29, should therefore be referred to.

The question is sometimes asked, whether the operation of the cut-out in any way depends upon the state of charge of the battery. There is no such relation between the two ; the sole function of the cut-out is to switch on the dynamo with rising engine speed, and to disconnect it when the engine slows down and stops.

### **Absence of Fuses.**

In order to simplify the system as far as possible, no fuse is provided. If all the connections are kept clean and tight, there is no possibility of any excess current causing damage to the apparatus.

### **Lubrication.**

As all the bearings and the gear wheels are packed with grease before leaving the works, lubricators are not provided. After the motor cycle has run, say, 10,000 miles, the " Mag-dyno " should be dismantled for cleaning, adjustment and repacking with grease. This is carried out preferably at the nearest Lucas Service Depot.

### **HEAD LAMP.**

The head lamp can be mounted in a low position, as the controlling switch is fitted in the top of the lamp and can be easily operated even when riding at speed. Another feature of the lamp is that an ammeter is incorporated in the back of the lamp so that it is readily visible to the rider. When the lamp is switched on, the ammeter is illuminated by indirect lighting. This

is arranged by means of a small aperture "D" (Fig. 2) in the reflector, from which light is reflected across the dial through slots in the ammeter case. A special mask is placed across the ammeter dial to prevent any glare that would tend to distract the rider's attention from the road.

The ammeter gives the driver an indication of the amount of current in amperes by which the battery is being charged or discharged under the various conditions governed by the particular position of the switch.

The head lamp is fitted with two bulbs, a high power gas-filled one for normal driving, and a small pilot bulb for use when the machine is standing or when driving in towns.

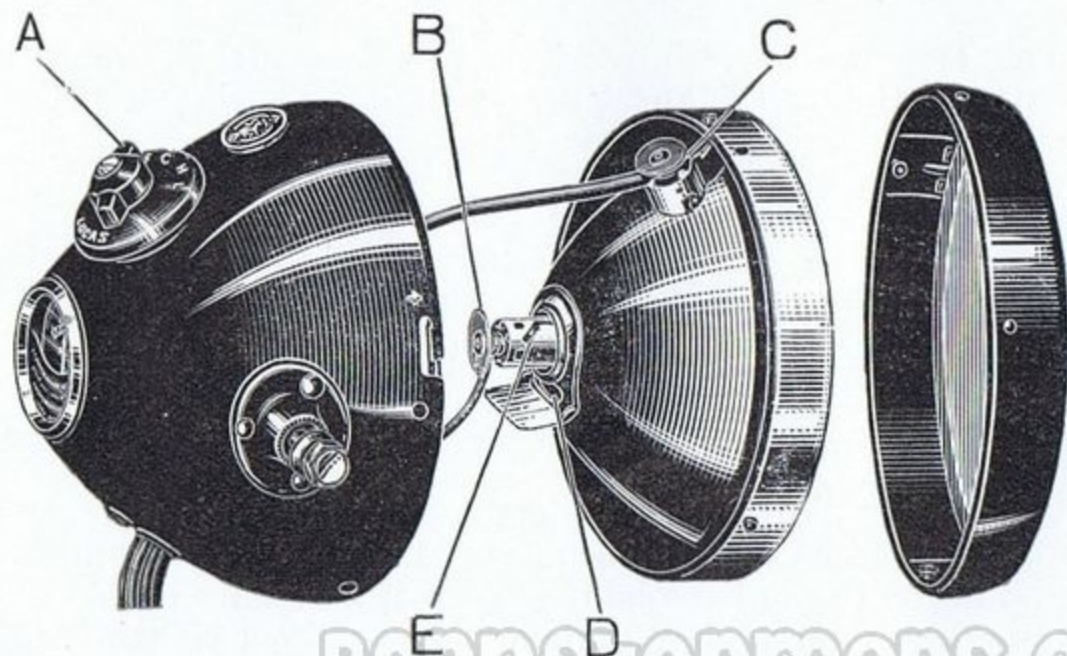

A—Switch.

B—Spring terminal for driving light bulb.

C—Spring terminal for pilot light bulb.

D—Aperture through which light passes to illuminate ammeter.

E—Focussing notches.

FIG. 2. HEADLAMP TYPE SS49, DISMANTLED.



## **Removing the Lamp Front and Reflector.**

The front and reflector of this lamp are locked in their bayonet slots by a patented arrangement of locking springs. To remove the lamp front, hold the sides of the lamp with the fingers, press the front rim evenly with the thumbs and palms of the hands, and then rotate to the left (looking at the front of the lamp) as far as possible, when the front may easily be withdrawn. The reflector is next removed by evenly pressing the rim and turning to the left, when the studs will disengage themselves from the slots in the body.

When replacing the reflector, see that the studs pass through their respective slots in the lamp body ; then turn to the right until the stop is reached. The word " TOP," which is stamped on the reflector, should then be at the top of the lamp, and opposite the indication mark or medallion.

## **Focussing the Head Lamp.**

The very accurate formation and particularly high finish of the surface of the reflector is the result of many years of research work, manufacturing experience, and prolonged night driving observations on the road. If, however, the bulb is not correctly focussed, the advantages of this scientific design are lost ; it is, therefore, essential that the filament should be approximately at the focus of the reflector. In order to arrange this, the lamp holder is provided with three notches, so that, by trying the bulb in the alternative positions, it can be placed as near as possible to the correct focus.

The best way of focussing and setting the lamp is to take the motor cycle to a straight, level road, try the bulb in each of the three notches, and then move the lamp on its adjustable mounting until the best road position is obtained. The high light should be switched on when focussing is carried out.

## Switch Positions.

The four positions are:—

“**Off.**”—Lamps off, and dynamo not charging.

“**C.**”—Lamps off and dynamo giving half its normal output.

“**L.**”—Head lamp (pilot light), tail lamp and side car lamp (when fitted) on; dynamo giving maximum output.

“**H.**”—With the exception that the driving light is in the place of the pilot light, the conditions are exactly the same as in position “**L.**”

## Side Car Lamp.

The methods for removing the lamp front and reflector and for focussing are exactly the same as for the head lamp. As an “earth return” wiring system is used, the lamp holder is arranged for a single contact bulb.

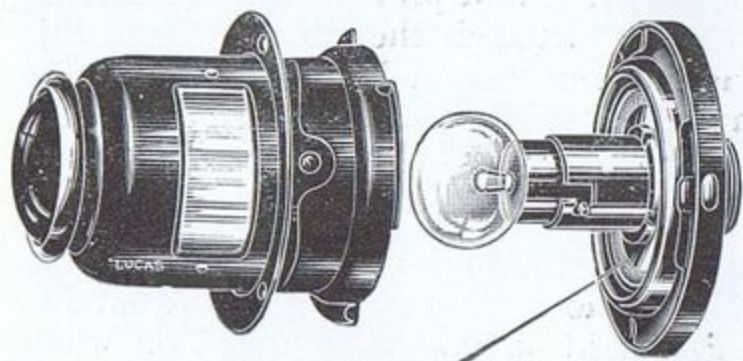

*Rubber Diaphragm.*

FIG. 3. TAIL LAMP.

## Tail Lamp.

This lamp is usually mounted directly on the number plate; it displays a red light to the rear, and through a side window illuminates the number plate.

The bulb holder is mounted on a rubber diaphragm (Fig. 3), which prevents road and engine vibration from being transmitted to the filament, thus greatly prolonging its life.

The rear portion of the lamp is removed for bulb replacements by giving it a half turn to the left, when it becomes detached from its bayonet fixing.

### Care of the Lamps.

As is well known, the efficiency of a lamp depends not only on the shape of the reflector, but on its surface. When the lamp is used under normal conditions, it is not advisable to polish the reflector ; should it, however, become marked or dull, repolish it with a good chamois leather, but on no account use any metal polishes. When replacing a bulb, removing or refitting a reflector, care should be taken not to touch the polished surface with the fingers.

If the ebony black of the outer body becomes dull in service, the original finish can be restored, no matter how neglected it may be, by a good furniture or car polish.

### Replacement of Bulbs.

When the replacement of any bulb is necessary, we strongly recommend that Lucas official bulbs are used. The filaments are arranged to be in focus, and give the best results with our reflectors. Particulars of the bulbs fitted in the lamps are given below.

FOR	NO.	WATTS.	REMARKS.
Head lamp (high light) ..	B.A.S. No. 2S	18	Centre contact, gas filled bulb.
Head lamp (low light), Sidecar and Tail lamp ...	B.A.S. No. 8S	3	Centre contact, vacuum bulb.

## BATTERY.

We would impress upon the owner the importance of the battery in the electrical equipment, and the necessity for careful treatment and regular attention if it is to be kept in good condition.

The chemical nature of the secondary battery must always be kept in mind, when considering how much attention is necessary in order that it will function properly under all conditions of use.

It is the chemical condition of the cell which determines its useful life, and limits the work it can do ; only a much-restricted yield of electrical energy is possible unless the chemical condition of the plates is good. It is for that reason that manufacturers give detailed instructions for the first charge and subsequent care of the battery. The sulphuric acid solution used in filling up the cells must be quite pure and of the correct density (1.285 at 60° F.) and it is important that the level of the electrolyte should be kept above the top of the plates, but well short of the bottom of the vent plugs. Neglect of this simple precaution will seriously impair the efficiency of the battery. Under ordinary conditions, it will be found necessary to adjust the level of the acid solution in the cells by adding distilled water at least once a month. The top of the battery should be kept clean and dry ; care should be taken not to spill water or acid on it when adjusting the level of the electrolyte.

The initial charge should be given in accordance with the printed instruction sheet supplied with every uncharged battery ; all subsequent charging should be at the correct rate and for a sufficient period of time to ensure the normal evolution of gas from all the plates.

Only distilled water should be added, to replace the loss of the electrolyte caused by the action of the charging current. If, however, acid solution is spilled, it should be replaced by topping up the cells with a diluted sulphuric acid solution of specific gravity as indicated on the side or lid of the battery.

The porcelain vent plugs in the top of the battery can be readily removed for inspection of the level of the solution in the cells ; it is important, when examining the cells in this way, that naked lights should not be held near the vents, on account of the possible danger of igniting the gas coming from the plates. When the battery is under examination, it is as well to complete the inspection of the cells by checking the specific gravity of the acid, as the density of the solution gives a very good indication of the condition of the battery. An instrument known as a " hydrometer " is employed for this purpose, and should be of the syphon type, as illustrated (see Fig. 4).

Voltmeter readings of each cell do not provide a reliable indication of the conditions of the battery, unless special precautions are taken which make such tests unsuitable for the average owner ; on that account, we do not recommend this test.

If the equipment is laid by for several months, the battery must be given a small charge from a separate source of electrical energy at least once a fortnight, in order to obviate any permanent sulphation of the plates. In no circumstances must the electrolyte be removed from the battery or the plates allowed to dry, as certain changes take place which result in loss of capacity.

The cables are sweated directly to the battery lugs, which are burnt on to the battery posts. This forms a terminal connection which will not be affected by acid fumes. For wiring the battery, see page 15.

We may summarise the chief precautions that should be taken to maintain the battery in good condition as follows :—

1. Keep the acid level,  $\frac{3}{8}$ " above the top of the plates.
2. Add distilled water only, never tap water.
3. Take frequent readings of the specific gravity, by means of the hydrometer (see page 12).
4. Do not allow the battery to remain discharged ; if run down, whatever the cause, recharge at once.

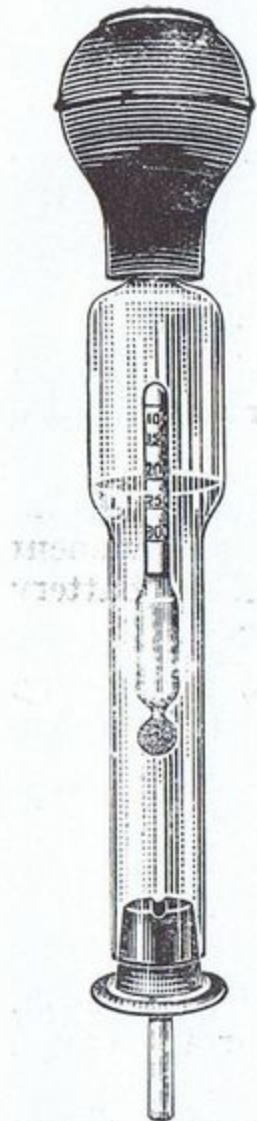

FIG. 4. SYPHON  
HYDROMETER.

## Instructions for using the LUCAS SYPHON HYDROMETER.

Before measuring the specific gravity of the acid solution by means of the hydrometer, see that the acid is at its correct level. Readings should be taken after a run on the motor cycle, when the electrolyte is thoroughly mixed.

To assemble the hydrometer, insert the float, thin end first, into the barrel; then wet the plug carrying the rubber tube and push it into position, and the instrument is ready for use. Holding the instrument vertically, compress the bulb and insert the red rubber tube as far as possible into the electrolyte; then gradually lessen the pressure on the bulb until the acid solution rises in the barrel enough to lift the hydrometer float about  $1\frac{1}{2}$ ". Removing the hydrometer from the cell, note the scale reading at the surface of the electrolyte; this gives the density or specific gravity.

Care must be taken that the stem of the float does not touch any part of the barrel or bulb while the reading is actually being taken.

The specific gravity of the electrolyte in the battery should be as follows: 1.285-1.300 when fully charged, about 1.210 when half discharged and about 1.150 when fully discharged. These figures are given assuming the temperature of the solution is about  $60^{\circ}$  F.

For fuller particulars regarding temperature corrections, see our "First Charge" instructions, a copy of which can be obtained on application.

## Period for which a Battery should be Charged.

It is difficult to lay down rigid instructions on this subject, as the conditions under which motor cycles are used vary very considerably, and obviously, the amount of charging a battery will require is directly dependent on the extent to which the lamps are used. The following suggestions will serve as a rough guide :—

The switch should be left in the “ C ” position for about 1 hour daily. This time should only be increased if the period of night running is considerable, or when the battery is found to be in a low state of charge (if the specific gravity of the acid solution is 1.210 or below).

## WIRING.

The equipment is designed for wiring on the “ earth return ” system ; care should be taken to see that the various cables are not chafed or cut in any way, through being jammed in the frame, as any injury to the insulation is liable to cause a “ short,” which will quickly discharge and seriously damage the battery. It is also very important to see that the head lamp, side car lamp, tail lamp, and negative connections are in good electrical contact with the machine frame ; this is just as essential as tightening up the insulated connections.

Standard 5m/m single ignition cable, obtainable at almost any garage, is employed throughout.

### Wiring the Switch.

To wire the switch, remove the lamp front and reflector, as described on page 7, when the switch terminals are exposed to view (see Figs. 2 and 5). The lamp spring terminals at

the back of the reflector are wired to the terminals in the switch before leaving the works. To prevent the reflector being damaged during the wiring of the switch, it is advisable to disconnect at the lamp holders, so that the reflector can be removed from the lamp.

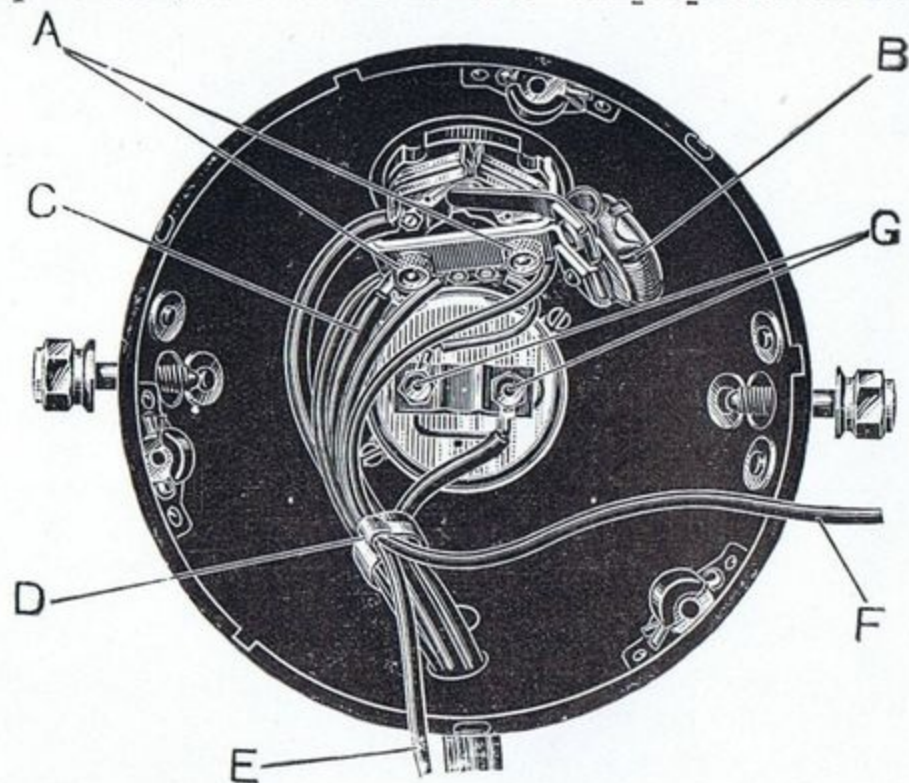

FIG. 5. INSIDE OF LAMP BODY.

A—Screws securing fixing bridge.

B—Half charge resistance.

C—Earthing cable.

D—Cable clip.

E—Cable to driving light bulb holder

F—Cable to pilot light bulb holder.

G—Ammeter terminals.

All the cables to the switch, that is, two from the "Magdyno," one from the tail lamp, one from the battery, and one earthing cable (connected to some part of the machine frame), should be pulled through the stem of the lamp. The end of the cable from the battery terminal should be bared and fitted with a 5 m/m metal eyelet, and then secured by means of the nut to the right-hand ammeter terminal as shown in the wiring diagram at the end of the booklet.



To render the switch terminals more accessible for wiring, remove the resistance " B " (Fig. 5), and the fixing bridge, after unscrewing the two nuts " A." The ends of the remaining cables should be bared and clamped into their respective terminals, by means of the grub screws (see wiring diagram). Now replace the fixing bridge and resistance, and then fit the end of the earthing cable " C " with an eyelet and secure it under one of the nuts " A."

Before replacing the reflector, the cable clip " D " (Fig. 5) should be bent round the cables, to secure them and so prevent any strain on the terminals.

### **Wiring the Head Lamp.**

To connect up the lamp terminals, compress the spring on the terminal until the hole on the stud is seen into which the bared cable should be threaded. The terminal on the small bulb holder should be connected to switch terminal " L " and the terminal on the large bulb holder to the terminal " H."

### **Wiring the Battery.**

The cable from the positive battery terminal is connected to the cable from the right hand ammeter terminal in the switch by means of a special brass connector provided. Care must be taken that the rubber shield is pulled over the connection after it has been tightened up.

The cable from the negative terminal must be secured in good electrical contact with the frame of the machine. For instance, it may be soldered to an eyelet which in turn must be secured by a bolt ; care must be taken to remove the enamel where the eyelet makes contact with the frame.

## HINTS FOR THE DETECTION OF LIGHTING FAULTS.

Although every precaution is taken to eliminate all possible causes of trouble, failure may occasionally develop through lack of attention to the equipment or damage to the wiring. The most probable faults are tabulated, according to the symptoms which are displayed, in the fault-finding tables at the end of the booklet.

We give a few hints on the best way to make use of these tables, as the sources of many troubles are by no means obvious.

Much evidence can be gained from observation of the ammeter. If, for instance, no reading is indicated, when the engine is running at, say, 20 miles per hour with the switch in the " C " position, the dynamo is failing to charge. To ensure that the ammeter is not at fault, the engine should be stopped and the switch turned to the " H " position, when a reading on the discharge side of the scale should be observed. Again, if the needle fluctuates, when the engine is running steadily, an intermittent dynamo output can be suspected. The dynamo may have been neglected, and the trouble could be caused by, say, worn brushes or a dirty commutator.

Should the intensity of the lights vary, or should they fail entirely, it is probably due to the battery terminals being allowed to corrode, and the consequent breaking of a connection, or to a defective earth connection. If the cause of the trouble is not located at the battery, the switch should next be examined to see that all the terminals are tight. If one particular lamp does not light, look for a broken filament, a broken cable from the lamp to the switch, or a defective electrical contact between the lamp body and the machine frame. When the engine is not running and the lamps light when switched on, but gradually go out, the battery is probably exhausted, due to excessive use of lights when stationary, or to the dynamo failing to charge. If it is found that the battery is the cause of the trouble, have it removed from the machine and examined. If the battery is merely exhausted, have it charged up from an independent electrical supply.

## THE MAGNETO.

During the last twenty years, an immense amount of research has been carried out, and experience gained, in the construction of ignition apparatus, and, as a result, the magneto of to-day has reached a very high level, both as regards its performance and its reliability. The best service and longest life, however, will never be obtained if the magneto is neglected, allowed to get dirty, or is run when out of adjustment. On this account the owner is urged to make an occasional inspection of his magneto, carefully following up each detail referred to below. Such attention as is usually required need take no more than a few minutes, and is an important factor in maintaining the ignition system in first-class condition.

### Cleaning.

Remove the pickups occasionally. This is accomplished by swinging aside the flat holding-on spring. The pickup is then easily removed by gently pulling it away ; it should be wiped clean and polished with a fine dry cloth. See that each brush works freely in its holder, and clean the brush, if necessary, with a cloth moistened with a few drops of petrol. With the pickups still removed, carefully clean the slip ring track and flanges by holding a soft cloth on the ring by means of a suitably shaped piece of wood, while the engine is slowly turned round.

The contact breaker should then be examined. Swing aside the spring " S " (Fig. 1) and remove the cover " T," when the contact breaker will be exposed to view. It is essential that the latter is kept spotlessly clean ; above all, the contact-points themselves must be free from all traces of oil. Want of attention to this precaution may not only be the cause of misfiring, but may result in the destruction of the contacts. Instructions for removing the contact breaker, should this be necessary, are given on page 19.

The foregoing hints can be summarised in a few words : neglect is sure to lead to trouble in the end. Dirt, carbon or metal dust, and water in any form are the enemies of good insulation, therefore keep the magneto clean and dry.

## Adjustment of Sparking Plugs and Contact Breaker.

The plug electrodes are bound to burn away slightly, and thus, in time, the gap length increases; it is a good plan to examine and clean them at intervals, adjusting them if necessary to the right setting: this should be about 20 thousandths of an inch. This gap is about twice that to which the contact breaker points should be adjusted, for setting which a gauge of about 12 thousandths thickness is provided on the side of the magneto spanner supplied with the magneto.

Providing the contact breaker points are kept clean, and above all *free from oil*, they will probably need adjustment only at long intervals. The reader is warned that it is not desirable to alter the setting unless the gap varies considerably from that of the gauge.

If adjustment is necessary, turn the engine round slowly until the points are seen to be fully opened, then using the magneto spanner, slacken the locking nut "E" (Fig. 6), and rotate the fixed contact screw by the hexagon head "F" until the gap at "D" is set to the thickness of the gauge; then screw up the nut "E" again until it is firmly locked.

Care should be taken that the gap is not appreciably greater than the standard amount, as an unduly wide opening would not only be a possible cause of misfiring, but would also be apt to cause undue wear.

If, when the contact points are examined, it is found that they have been burned or blackened (owing, probably, to the presence at some time or other of oil or dirt), they may be cleaned with very fine emery cloth and afterwards with a cloth moistened with petrol. Care must be taken that all particles of dirt and metal dust are wiped away.

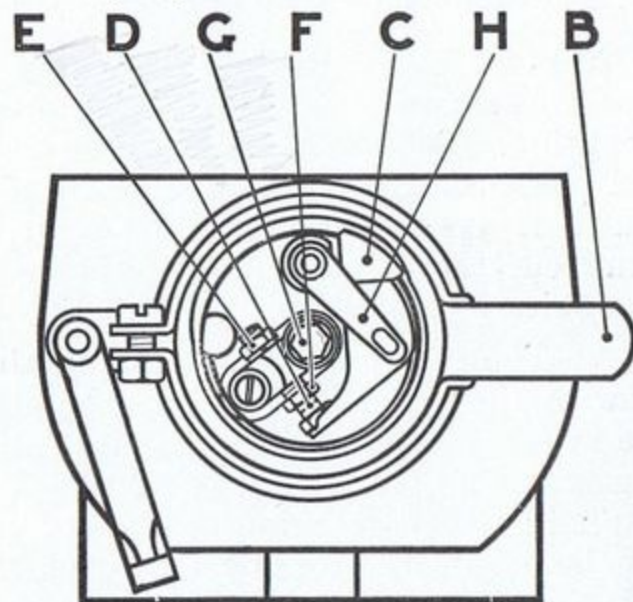

FIG. 6.

- |                   |                       |
|-------------------|-----------------------|
| B—Timing lever.   | E—Locking nut.        |
| C—Fibre heel.     | F—Contact screw head. |
| D—Contact points. | G—Fixing screw.       |
|                   | H—Locating spring.    |

To render the points accessible for cleaning, etc., it is necessary to withdraw the contact breaker from its housing by unscrewing the hexagon headed screw " G " by means of the magneto spanner. The whole contact breaker can then be pulled off the tapered shaft on which it fits. Now push aside the locating spring " H " and prise the rocker arm off its bearings, when it will be possible to begin cleaning the points.

When replacing the contact breaker, care should be taken to ensure that the projecting key on the tapered portion of the contact breaker base engages with the key-way cut in the armature spindle, or the whole timing of the magneto will be upset. The hexagon-headed screw should be tightened up with care ; it must not be too slack, nor must undue force be used.

### **Retarded Ignition.**

A driver is commonly advised to keep his timing lever advanced, retarding it only when necessary, e.g., for starting and for hill climbing. This is sound advice, for it not only enables more power to be developed and petrol economised, but the magneto is helped.

### **Lubrication.**

The bearings are packed with grease before leaving the works, and do not require oiling.

### **HINTS FOR THE DETECTION AND REMEDY OF IGNITION FAULTS.**

If a failure of the ignition is suspected, unless the cause is at once apparent, the reader is strongly recommended to proceed in accordance with the following routine, which should quickly enable him to locate the trouble.

See, first, if the plug lead or the plug are causing the fault. An examination of the high-tension cables may reveal the trouble ; the rubber may show signs of perishing or cracking ; it will not last for ever. If a spare plug is at hand, it may be substituted for the suspected one, or if it is

merely the gap that is too large, it may be adjusted (see page 18). Missing with full throttle is sometimes due to the plug gap being too wide. Bad plug insulation is sometimes caused through sooting, and may occasionally be remedied by washing the plug out with petrol. It is sometimes recommended to remove the plug, and, allowing the body to rest on the cylinder head, to observe whether a spark occurs at the points when the engine is slowly turned. It should, however, be noted that this is only a rough test, since it is possible that a spark may not take place when the plug is under compression. If it is suspected that the ignition has failed completely, this may be checked by removing from the plug terminals the high-tension cable and observing whether a spark takes place on turning the engine round with the terminal lead held about  $\frac{1}{8}$ " from some metal part of the engine. If no spark occurs, examine the contact breaker ; slowly turn the engine over, and observe the action of the contact breaker rocker arm ; it is possible that the arm is not answering to its control spring, and is remaining permanently open as it is rotated. If this appears to be so, remove the contact breaker and applying pressure with the finger on the fibre heel " C " (Fig. 6), observe whether the points readily open and close. If they are at all sluggish, push aside the locating spring " H " (Fig. 6), and prising the rocker arm off its bearing, examine the steel pin on which it works, cleaning this, if required, with fine emery cloth, wiping away all grit, and moistening the pin with oil before replacing the lever. We need hardly warn the reader that no trace of oil should be left anywhere near the contact points after this has been done.

If the " Magdyno " has recently been replaced on the motor cycle, it is possible that it may have been timed incorrectly. Instructions for timing are given below, but unless the reader is used to it, retiming the magneto is by no means a simple matter, and he would be well advised to have this done for him at his nearest garage.

If, after exhausting the above scheme of examination, the reader is still in doubt or difficulty about his ignition system, it is little use continuing the examination, and he is strongly advised to consult the nearest Lucas Service Depot, the addresses of which are given on page 25.

## INSTRUCTIONS FOR TIMING.

### For Two and " V " Cylinder Engines.

1. Slacken the magneto coupling securing nuts on the armature spindle, or the magneto chain sprocket to enable the " Magdyno " to be turned independently of the engine.

2. The order of firing having been ascertained, rotate the engine till No. 1 Piston is at the top of its compression stroke (that is, on top dead centre). On " V " twin cycle engines, the rear cylinder is usually No. 1.

3. Remove No. 1 pickup and turn the " Magdyno " spindle forward, i.e., in the normal direction of rotation, until the brass segment of the slip-ring can be seen.

4. With the " Magdynos " provided with variable ignition, the ignition control or the timing lever " B " (Fig. 8) should be moved to the fully retarded position, that is, to the limit of its travel in the forward direction.

5. Remove the contact breaker cover and turn the magneto spindle in its normal direction of rotation until the fibre heel " C " begins to rise on the inclined plane of the cam ring just sufficiently to separate the points " D." This position is the firing point, and the magneto drive should be permanently fixed in this position.

NOTE.—The above setting is standard for most types of engines ; that is, the magneto is fully retarded when the piston is on top dead centre. In all cases, however, the engine-maker's instructions should be consulted when retiming any magneto.

6. It is always advisable to check the timing after tightening up, to ensure that no movement has taken place.

## For Single Cylinder Engines.

The timing may be proceeded with exactly as for two cylinder engines, except for the obvious fact that there is no firing order to be ascertained.

## Engines with Fixed Ignition.

The magneto is usually timed to fire at an angle of from  $15^{\circ}$  to  $20^{\circ}$  before top dead centre, or about two inches measured on the flywheel rim. It is impossible to give more definite instructions, the engine-maker's recommendations should be followed.

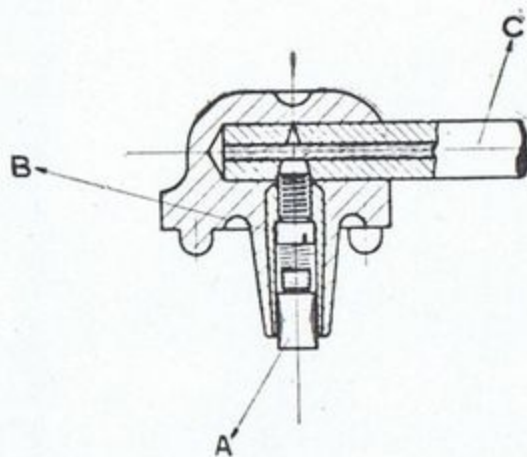

### Fitting of High Tension Cable.

The pickups are provided with concealed terminals. To wire up, the cable *must not be bared*, but should be cut off flush to the required length. Then remove the brush and spring "A" (Fig. 7), and screw "B" from the pickup and push the cable "C" hard home.

Replace and tighten up the screw, which will pierce the insulation and make contact with the cable core. The brush and spring should then be replaced in the pickup and the pickup fitted to the machine.

FIG. 7.  
SECTION OF PICK-UP.

- A—Carbon brush.
- B—Screw.
- C—Cable.

NOTE.—Use only 7 m/m diameter cable. Do not attempt to use a thicker cable pared down to fit.



## INSTRUCTIONS FOR FITTING BOWDEN CABLE TO THE SPRING CONTROL.

Remove the screw "A" (Fig. 8), and then, without dismantling any part of the control, thread the Bowden cable through the cable stop "B." Pass it through the control until it emerges at the hole left by the screw "A." Now solder the brass nipple "C" to the end of the cable, and then pull it from the other end until it is felt that the nipple fits into the end of the plunger "D," when the screw "A" should be replaced.

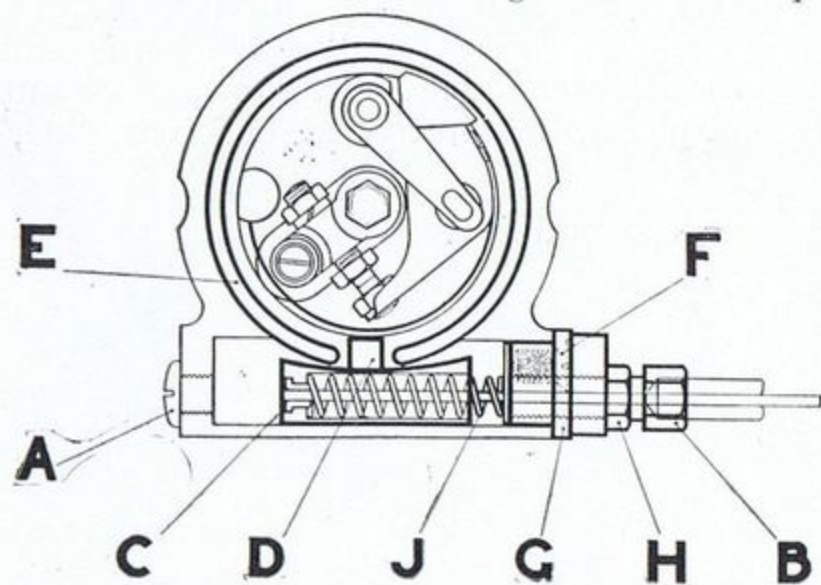

FIG. 8. SECTION OF SPRING CONTROL.

- |                 |                           |
|-----------------|---------------------------|
| A—Screw.        | B—Cable stop.             |
| C—Brass nipple. | D—Plunger.                |
| E—Cam ring.     | F—End plate fixing screw. |
| G—End plate.    | H—Lock nut.               |
| J—Spring.       |                           |

By referring to Fig. 8, it will be seen that on applying a tension to the Bowden cable, the plunger "D" will move the cam ring "E" and so alter the timing of the magneto.

Instructions cannot be given for fitting the cable to the ignition control lever, as the types of these vary with different makes of machines. It should be noted, however, that the cable stop "B" can be adjusted if necessary to take up any slight slackness of the cable covering between the magneto and the lever control.

Should it become necessary at any time to dismantle the spring control and Bowden cable, proceed as follows :—

First remove the metal cover of the contact breaker, which is held in position by a spring arm, and then withdraw the cam ring " E." Next, unscrew the fixing screw " F," which is sunk flush with the surface of the end plate " G." Then pull the Bowden cable and this will come out, together with cable stop " B " (which screws into the end plate), lock nut " H," end plate " G," and plunger " D."

These operations should, of course, be reversed when assembling.

# LUCAS SERVICE DEPOTS

*In the event of any difficulty with any part of the equipment, no matter how trivial, we shall be only too pleased to give every assistance possible. The best course to adopt is to call at the nearest Lucas Service Depot (the addresses of which are given below), when the equipment can be examined as a whole. The depots are not only at your disposal for repairs, overhauls and adjustments, but to give free advice. If it is necessary, however, to communicate, or when ordering spare parts, always give the type and number of the unit in question, the make and, if possible, the date of the Motor-Cycle on which it is fitted.*

<b>BELFAST</b> ... ..	... 3/5, Calvin Street, Mountpottinger
Telephone: BELFAST 7017.	Telegrams: "SERVDEP, BELFAST"
<b>BIRMINGHAM</b> ... ..	... Great Hampton Street
Telephone: CENTRAL 8401 (10 lines).	Telegrams: "LUCAS, BIRMINGHAM"
<b>BRISTOL</b> ... ..	... 345, Bath Road
Telephone: BRISTOL 8400 (4 lines)	Telegrams: "KINGLY, BRISTOL"
<b>CARDIFF</b> ... ..	... Penarth Roap
Telephone: CARDIFF 4603 (4 lines)	Telegrams: "LUCAS, CARDIFF"
<b>COVENTRY</b> ... ..	... Prioxy Street
Telephone: COVENTRY 3968 & 3841	Telegrams: "LUCAS, COVENTRY"
<b>DUBLIN</b> ... ..	... 41, Middle Abbey Street
Telephone: DUBLIN 653	Telegrams: "AUTOLITE, DUBLIN"
<b>GLASGOW</b> ... ..	... 227/229, St. George's Road
Telephone: DOUGLAS 3075 (3 lines)	Telegrams: "LUCAS, GLASGOW"
<b>LEEDS</b> ... ..	... 64, Roseville Road
Telephone: LEEDS 28591 (5 lines)	Telegrams: "LUSERDEP, LEEDS"
<b>LONDON</b> ... ..	... Dordrecht Road, Acton Vale, W.3.
Telephone: CHISWICK 3801 (18 lines)	Telegrams: "DYNOMAGNA, ACT, LONDON"
<b>LONDON</b> ... ..	... 759, High Road, Leyton, E.10.
Telephone: WALTHAMSTOW 2161 (3 lines)	Telegrams: "LUSERDEP, WALT, LONDON"
<b>LONDON</b> ... ..	... 155, Merton Road, Wandsworth, S.W.18
Telephone: PUTNEY 5131 (4 lines) & 550!	Telegrams: "LUSERV, WANDS, LONDON"
<b>MANCHESTER</b> ... ..	... Talbot Road, Stretford
Telephone: TRAFFORD PARK 1410 (3 lines)	Telegrams: "LUCAS, STRETFORD"
<b>NEWCASTLE-ON-TYNE</b> ... ..	... 64/66, St. Mary's Place
Telephone: CENTRAL 3571 (3 lines)	Telegrams: "MOTOLITE, NEWCASTLE-ON-TYNE"

# LUCAS OVERSEAS SERVICE STATIONS

## AFRICA.

### EGYPT.

Cairo - - - MORING & Co., 1, Sharia El-Antik-khana El-Masria.

### GOLD COAST.

Accra - - - TRADING ASSOCIATION OF NIGERIA LTD.

### NIGERIA.

Lagos - - - WEST AFRICAN MOTORS LTD., Broad Street.

Jos - - - WEST AFRICAN MOTORS LTD.

### UGANDA.

Kampala - JOHN CALVERT & Co. LTD.

### UNION OF SOUTH AFRICA AND RHODESIA.

Cape Town - STANSFIELD RATCLIFFE & Co. LTD., 8 Waterkant Street.

Durban - STANSFIELD RATCLIFFE & Co. LTD., 467, Smith Street.

Johannesburg - STANSFIELD RATCLIFFE & Co. LTD., 63, Anderson Street.

Sub-Stations in

East London - THE STERLING ENGINEERING Co., Buffalo Street.

Kimberley - AUTO ELECTRICAL SERVICE STATION, 44, De Beers Road.

Port Elizabeth - HALL & Co., Central Garage, Peel Street.

Bulawayo - SYKES (Rhodesia) LTD., Gifford House. (P.O. Box 230).

Salisbury - HUBERT DAVIES & Co., LTD.

## AMERICA.

### BRITISH WEST INDIES.

TRINIDAD - F. J. MILLER & Co., 17, Chacon Street, Port of Spain.

### SOUTH AMERICA.

Lima - - - ALEXANDER ECCLES & Co., Casilla 1939, Lima.

## ASIA.

### INDIA.

Bombay - - - BOMBAY BATTERY & ELEC. Co., 15, New Queen's Road.

Calcutta - - - THORNYCROFT (INDIA) LTD., 6, Lyons Range.  
(Works—Diamond Harbour Road).

Delhi - - - BRITISH MOTOR CAR Co. LTD., Kashmir Gate.

Lahore - - - WALTER LOCKE & Co. LTD., The Mall.

Madras - - - ADDISON & Co. LTD., Mount Road.

### BURMA.

Rangoon - - - WATSON & SON LTD., 59, Phayre Street.

## ASIA (Continued).

### CEYLON.

Colombo - - - EASTERN GARAGE LTD., Galle Face Garage (P.O. Box 260).

### STRAITS SETTLEMENTS & F.M.S.

Singapore - - - MALAYAN MOTORS LTD., 209/212, Orchard Road.

Kuala Lumpur - MALAYAN MOTORS LTD.

Penang - - - MALAYAN MOTORS LTD.

### CHINA.

Shanghai - - - AUTO PALACE Co. LTD., 484, Avenue Joffre.

Shanghai - - - DONG CHONG & SON, P.344-6, Nanking Road.

## AUSTRALIA.

Adelaide - - - HANNAN BROS. LTD., 129, Angus Street.

Sub-Stations in Broken Hill, Crystal Brook and Streaky Bay.

Brisbane - - - ELPHINSTONES LTD., Magneto House, Adelaide Street.

Sub-Stations in Cairns, Charleville, Clermont, Cloncurry, Gordonvale,  
Hughenden, Innisfail, Ipswich, Longreach, Mackay, Toowoomba,  
Townsville and Winton.

Melbourne - - - LUCAS SALES & SERVICE PTY. LTD.,  
183-187, Queensberry Street, Carlton.

Sub-Station in Geelong.

Perth - - - A. C. McCALLUM LTD., 96, Murray Street.

Sydney - - - BENNETT & WOOD LTD., 284-6, Pitt Street.

Sydney - - - MOODY & Co., Magneto House, 15, Goulburn Street.

Sub-Station in Newcastle - GRAY SHEDDON & Co. LTD., 19, Merewether St.

### TASMANIA.

Hobart - - - MEDHURST & SONS, 95, Collins Street.

Launceston - - - MEDHURST & SONS, 59, Brisbane Street.

## NEW ZEALAND.

Auckland - - - CROSER & SONS LTD., Lorne Street.

Wellington - - - L. M. SILVER & Co. LTD., 30, Tory Street.

Sub-Stations in Hawera, Hastings, Napier, Palmerston North  
and Stratford.

Christchurch - - - WOUFF & SALVESEN LTD., 32/34, Lichfield Street.

Sub-Stations in Ashburton, Dunedin, Invercargill and Timaru.

## EUROPE.

Available in most of the principal cities

# "MAGDYNO"

## FAULT FINDING TABLE FOR LIGHTING.

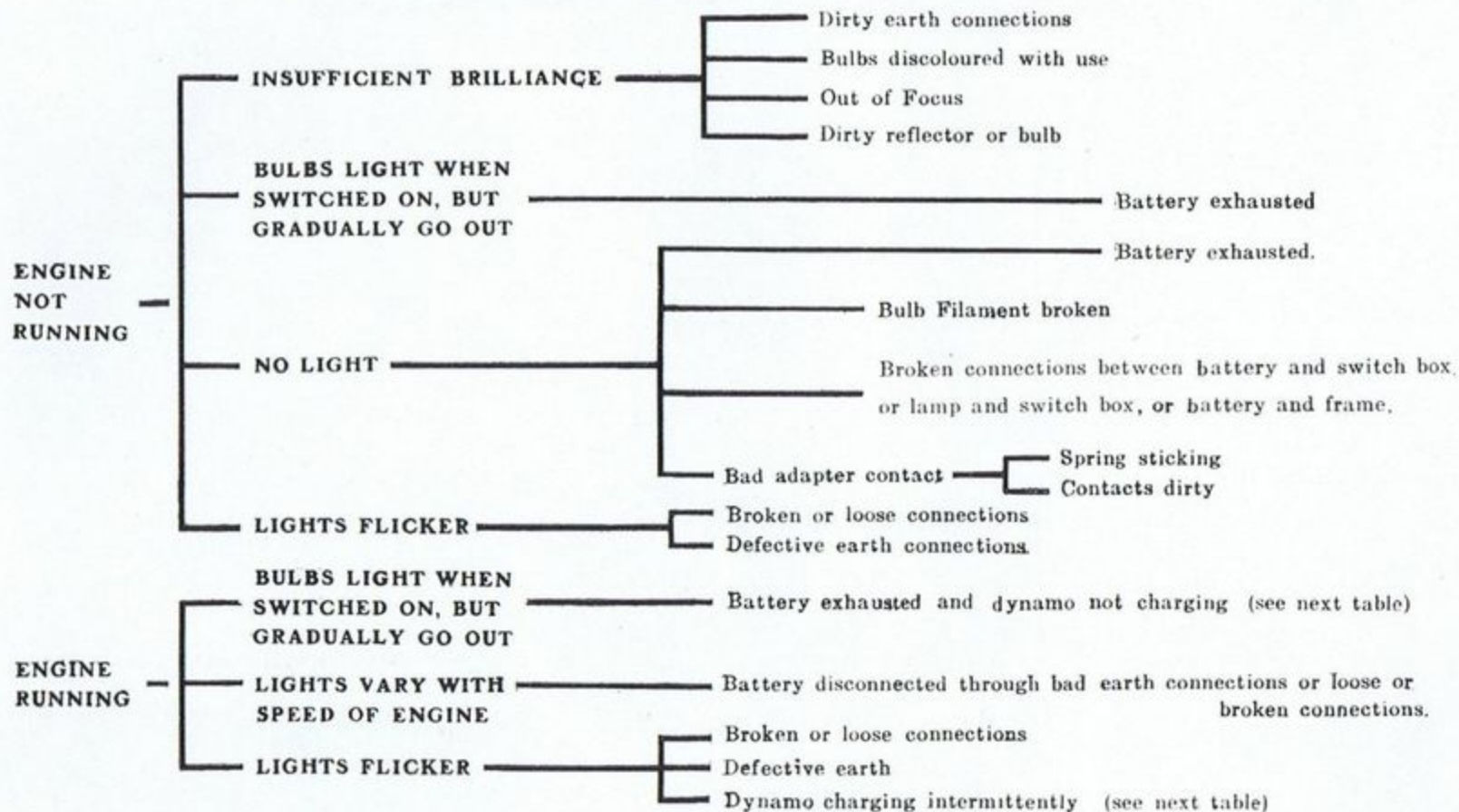

## FAULT FINDING TABLE FOR DYNAMO.

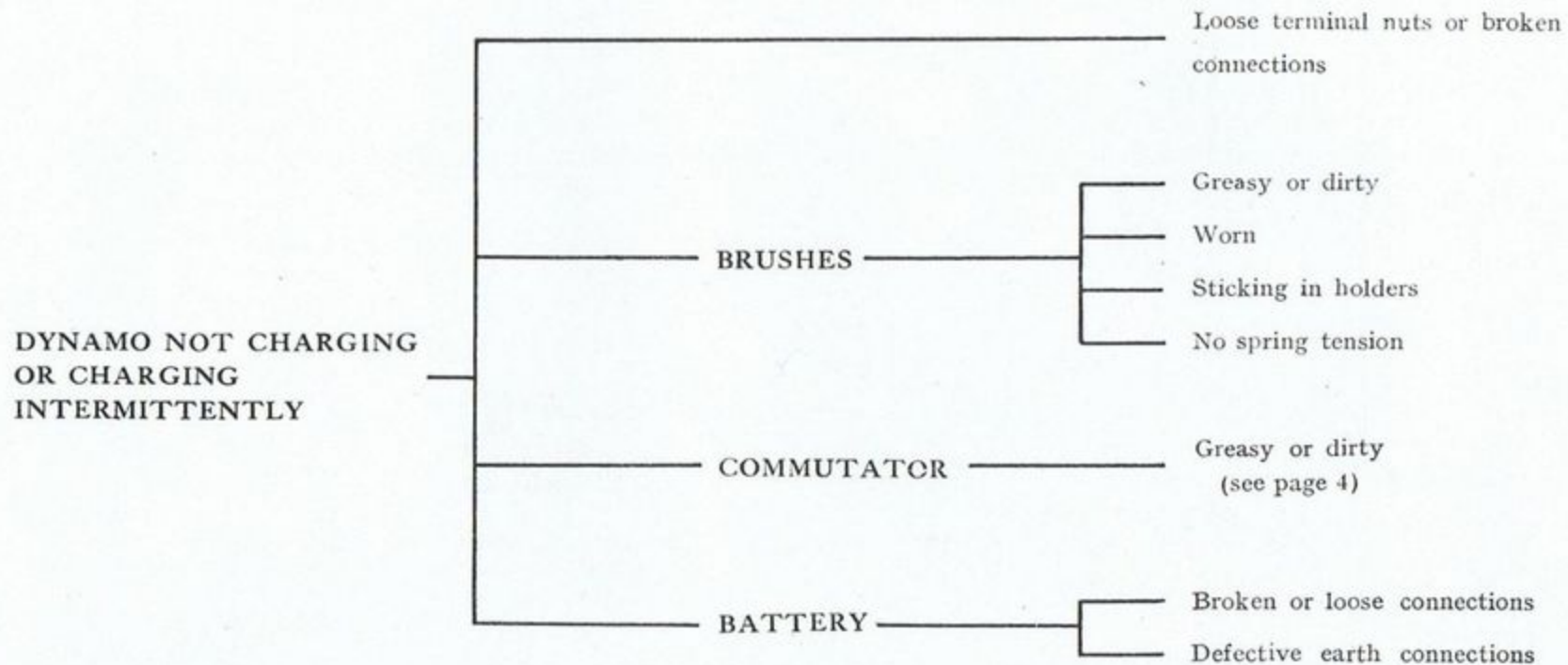

# "MAGDYNO"

## FAULT FINDING TABLE FOR IGNITION

