



INSTRUCTION
BOOK Barnstormers.co.nz **MARK II**

PLEASE NOTE—

Our Service Department is available for Spares, Repairs and advice in connection with your Mini-Motor. All correspondence MUST bear the Engine Number of your Unit (with prefix letter or letters), which will be found stamped on the crankcase just behind the magneto. In the case of claims for replacements under guarantee, the name and address of the supplier and date of purchase should also be given. The faulty parts must be returned before replacements will be supplied.

When writing on two different matters, please use two separate sheets, *i.e.*, do not include an order for spares in a letter asking for technical advice, otherwise delay may occur.

Goods sent to us for repair MUST BE SENT CARRIAGE PAID and be clearly marked with the name and address of sender, and a separate letter should be sent by post giving full details of work required. Otherwise goods will remain here unattended at owner's risk.

Spare Parts are fully illustrated at the back of this booklet and when ordering, it is only necessary to quote the part number shown for each item, and the engine number.

IMPORTANT—We do not carry out any work on, nor accept any responsibility for, the cycle parts of your machine. If complete machines are sent to us, every care is taken to ensure their safety against fire, theft and other damage, but all such machines are stored and driven for test purposes at owner's risk.

INTRODUCTORY

Equipped with this unit, your bicycle will be transformed into the simplest motor vehicle on the road, yet it will retain all the advantages of a bicycle.

The engine itself is constructed of a few sturdy parts and requires little attention. It is, nevertheless important that it be fitted with care, preferably by a mechanic or cycle dealer. Alternatively, by following the instructions given in this book the work may be carried out by anyone with ordinary mechanical aptitude.

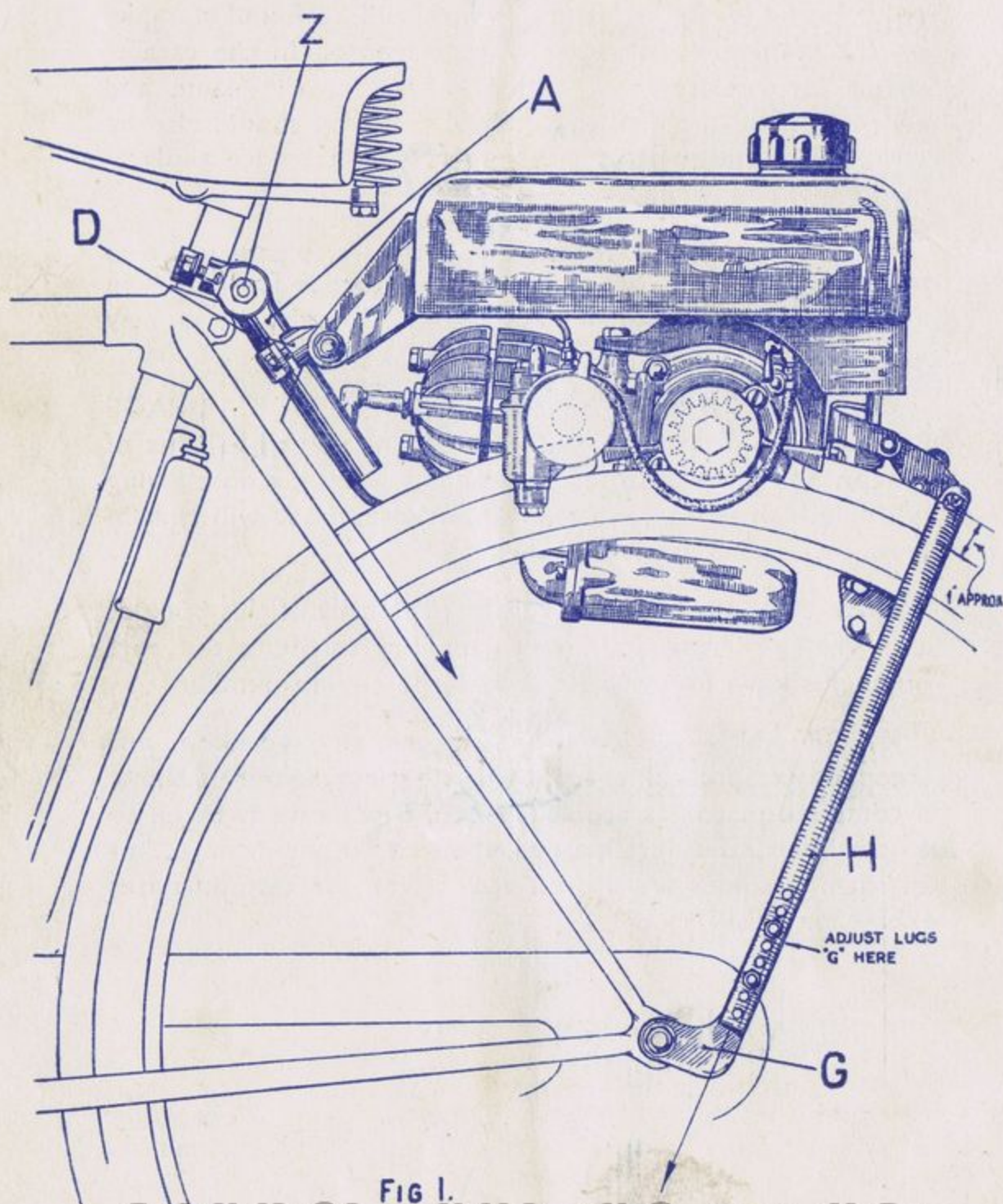

FIG 1.

Fig. 1.—To increase the pressure of the roller on the tyre, move the hinge lug "D" in the direction of the arrow for a small increase, or the U shaped fork "H" for larger increases.

FITTING INSTRUCTIONS

- (1) Rest the unit on the rear mudguard (if there is a carrier or other fitment over the rear wheel this must first be removed). Fasten the elbow lug "A" on to the saddle pillar as low as possible, but do not completely tighten the clamp bolts "B" (Fig. 2.)
- (2) Bring the petrol tank into a horizontal position by adjusting the clamping pieces "Z" on the elbow lug and sliding the hinge "D" up or down the elbow lug as required. (Fig. 1.)
- (3) Make a mark on the mudguard at a distance of about $\frac{1}{4}$ in. forward of the roller mudguard "E" remove the unit and cut the mudguard in two halves at the mark, allowing the rear portion of the cut mudguard to swing backward, leaving a space between the two ends. (Fig. 2.)

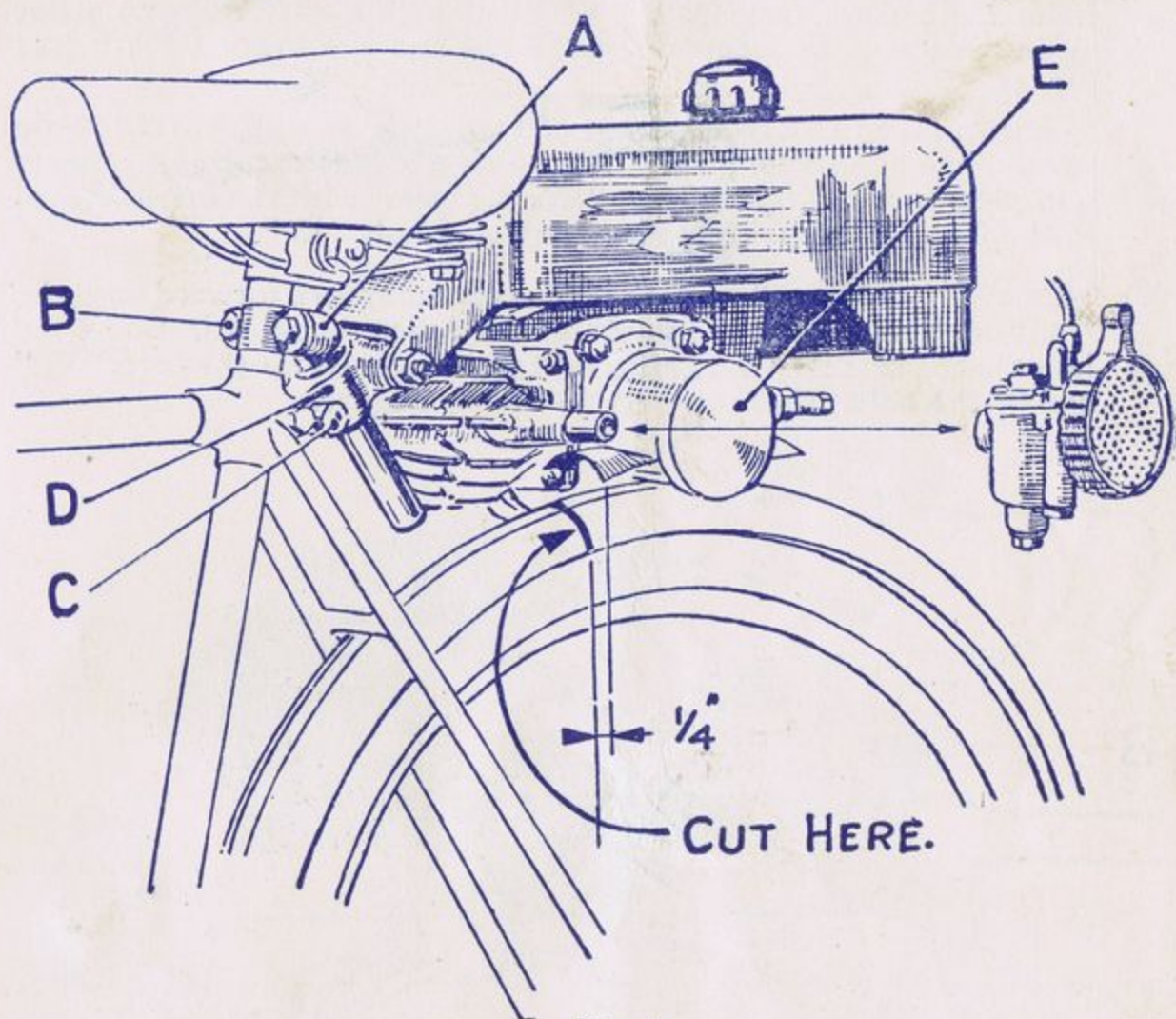

Fig. 2

- (4) Now replace the unit as before and the roller will rest on the tyre. Move again the sliding hinge "D" to bring the tank afresh into a horizontal position. Make sure now that the cylinder fins and the inlet tube are at least $\frac{1}{4}$ in. clear of the mudguard. If the clearance is less, it is necessary to cut away the sections of the mudguard which may endanger the free movement of the engine. (Fig. 3.)
- (5) Now look at the bicycle from the rear. Make sure that the tank top is parallel to the spindle of the rear wheel of the bicycle and that the roller rests well on the middle of the tyre.

- (6) Now tighten the clamp bolts "B" and sliding hinge bolts "C" (Fig. 3).
- (7) Undo the nuts of the wheel spindle and spring the U shaped fork "H" into position. Each branch of the fork carries at its lower end an adjustable lug "G." Fix the position of these lugs so that a space of about 1 in. is allowed between the tyre and the fork. (Fig. 1).

To fit the drive control remove long pivot pin "I" (Fig. 4) and locate drive control mechanism between the arms of bracket "Y." Aline holes in bracket and toggle arms "L." Insert pivot pin "I" and secure with split pin, at this point observing that the control has been assembled with the cable towards the rear. Now slacken clamping bolt "O" and pull guide rod "R" through adjustable pivot block "N" until the holes in the lower end of the guide rod aline with the holes in the quadrant plate "J" making sure that there is about $\frac{1}{16}$ in. clearance between the guide rod and the bracket "Y" (see Fig. 4).

Secure guide rod to quadrant plate and tighten up wheel spindle nuts. Slide adjustable pivot block up or down as required to obtain $\frac{1}{8}$ in. clearance between the tyre and the roller with the drive control in the free position. Tighten up clamping bolt "O".

- (8) Now swing the cut-off portion of the rear mudguard forward until the front edge is beneath the flange of the roller mudguard. Using the holes in the rear stay as a guide, drill the two holes for the bolts "Q" and fit the bolts; thus securing the rear mudguard.

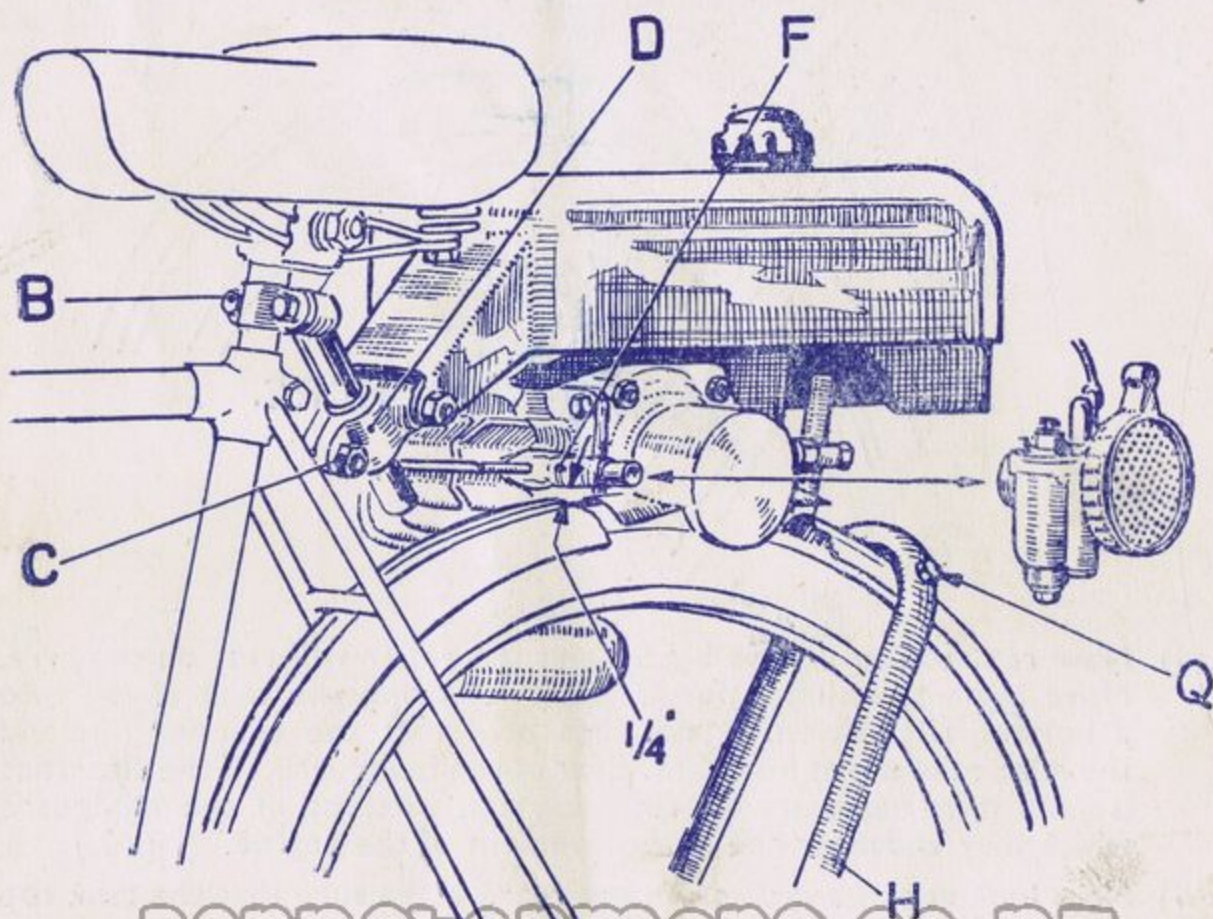

- (9) The controls should now be mounted on to the handlebars of the bicycle, the speed control (THROTTLE and DECOMPRESSOR) on the right-hand side, and the drive control on the left-hand side. Set the position of the control levers to be convenient, but make sure that the cables have easy sweeping bends and are not led round sharp corners or are "kinked"
- (10) The control cables are already coupled up to the appropriate levers, but adjusters are provided at the ends of the cables for the taking up of any slack that may develop in use. After making use of the adjusters always remember to tighten the locknuts.

IMPORTANT

With the cable correctly adjusted, the spring should return the drive control mechanism to the free position. This can be checked by observing that the three pivot points of the drive control mechanism marked "*" are in line (see Fig. 4).

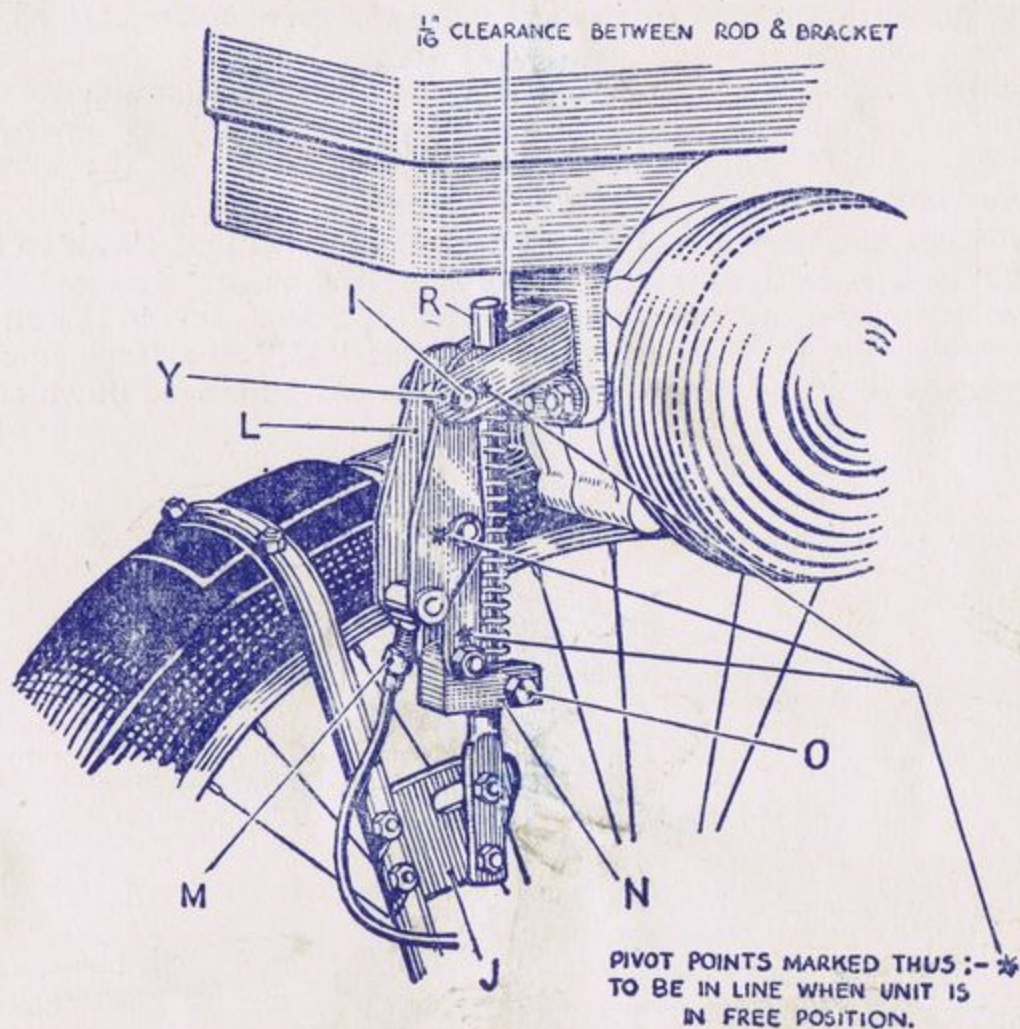
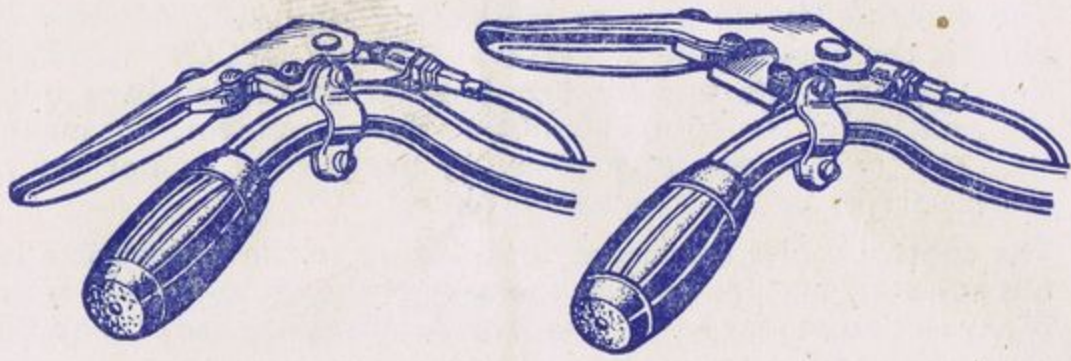

Fig. 4

- (11) Make sure that when the engine is engaged on the tyre (i.e., drive position of the handlebar lever) the roller does not slip if the bicycle is pushed. Also, that when the roller is lifted by means of the drive control lever the tyre must be able to accomplish a complete revolution without touching the roller at any point. If one of these conditions is not fulfilled, adjust the pressure of the roller on the tyre (see following paragraph).
- (12) Check that the float chamber of the carburettor is vertical.



DRIVE POSITION

FREE POSITION

Fig. 5

ADJUSTMENT OF ROLLER PRESSURE

In order to obtain good results from the engine, it is very important that the pressure exerted by the roller on the tyre is adequate to obtain a positive drive.

If the engine tends to race when you open the speed control lever abruptly, then the pressure of the roller on the tyre should be increased, this will avoid slippage of the roller on the tyre with consequential increase in rate of tyre wear.

To increase the pressure of the roller on the tyre, first check to ensure that the tyre is inflated hard. If slippage still occurs, slacken the nut "C" on the elbow lug "D" and slide the lug downwards in the direction of the arrow, Fig. 1. Then retighten the nut "C." If a large amount of adjustment is required, the U-shaped stay should be moved down another notch at "G," Fig. 1.

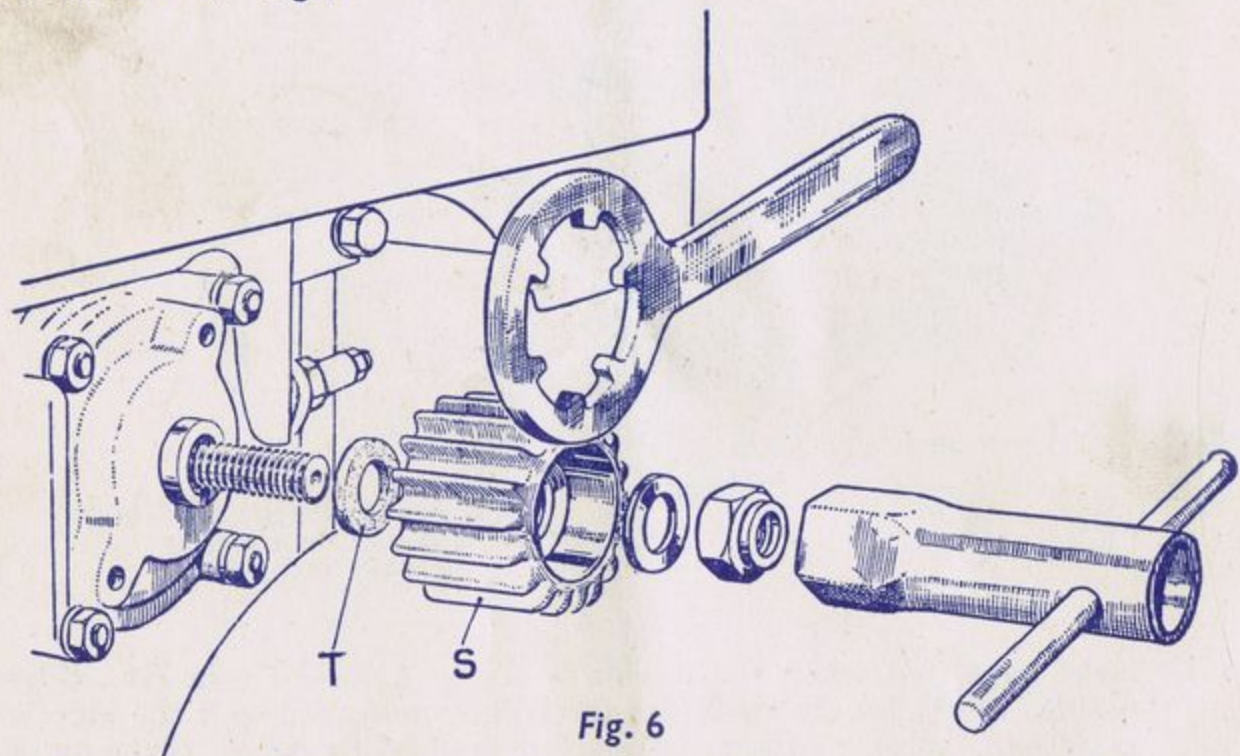

Fig. 6

The roller "S" is subjected to wear and in course of time may become so reduced in diameter as to lose its grip on the tyre. The pressure of the roller on the tyre may be restored by recourse to action outlined above. When, however, the roller is completely worn out it may easily be replaced.

REPLACEMENT OF ROLLER

- (1) First grasp the roller with the special spanner or large pair of pliers and undo the retaining nut Fig. 6. It is important that this instruction be followed carefully, as if an attempt is made to unscrew the nut while holding the magneto, damage to the crankshaft may result.
- (2) Having removed the nut and washers, the roller itself may now be unscrewed. It should come away quite easily and in this case it is permissible to grasp the magneto. If the roller will not unscrew easily it should be soaked in freeing oil and another attempt made after the oil has penetrated into the thread.
- (3) Reverse the operations to fit the new roller, making sure that the washers are replaced in the correct order, *i.e.*, the fibre washer "T" should be fitted between the crankcase and the roller "S," Fig. 6.

ENGINE DATA

Bore 38 mm.

Stroke 44 mm.

Capacity 49.9 cc.

Normal road speed: 20 m.p.h.

Ignition Timing: 29 degrees before top dead centre, or $\frac{1}{8}$ in. measured on the piston stroke.

Magneto { Flywheel Type.
Contact breaker gap: .018 in.

Type of Plug: LODGE C.14.
K.L.G. F.50.
CHAMPION J.8.

Plug Gap: .018"—.020".

Lubrication: Petroil (1 part of oil to 20 parts of petrol). See page 8.

Carburettor { Make: Trojan (made under Dellorto licence).
Choke: 9 mm.
Jet size: 43 ; (for temperate climates) (Smaller or larger jets may be required for hotter or colder climates.)

INSTRUCTIONS FOR THE USE OF THE MINI-MOTOR

FILLING UP

The unit runs on a mixture of petrol or gasoline and oil. First quality engine lubricant is required, some suitable oils are:

Castrolite	Single Shell	Mobiloil Arctic
Essolube 20	Regent/Caltex 20	Energol S.A.E. 20

If available an S.A.E. 10 oil can be used with advantage.

The proportions of the mixture of petrol or gasoline and oil are as follows:

20 parts petrol to 1 part of oil, equal to—

1 tank full petrol to 4 measures (in tank filler cap) of oil.

It is better to mix in petrol with the oil in a separate container before pouring into the fuel tank, but when this cannot be done it is important to operate in the following order:

- (1) Turn off the petrol tap under the tank ;
- (2) pour in the oil ;
- (3) pour in the petrol ;
- (4) shake the bicycle thoroughly before turning on the tap again.

TO START

Having turned on the petrol tap, depress the primer plunger " U " on the carburettor (Fig. 7) four or five times; place the mixture control in the " RICH " position (if this is the first time you have started the unit). Grasp and pull into the ratchet stop the drive control lever (long lever on left-hand side of handlebar) bringing the roller into contact with the tyre. Move the speed control lever (small lever on the right-hand side of handle-bar) to the right, thus opening the decompressor valve; mount the bicycle and pedal away. The engine will now be revolved, but will not commence firing. When speed has been gathered, move the speed control lever smartly towards the left, thereby closing the decompressor valve and opening the throttle half-way. The engine should now commence firing. Continue to pedal briskly until the engine is running smoothly, then your speed may be regulated by operation of the speed control lever.

If you wish to use the machine as an ordinary bicycle, lift the engine from the tyre by operating the drive control lever on the left-hand side of the handlebar.

**BUT REMEMBER TO STOP THE ENGINE BY SHUTTING
DOWN THE SPEED CONTROL LEVER.**

RUNNING IN

During the first four-hundred miles do not put too much strain on the engine. If the engine tends to slow down under effort open decompressor valve, by means of the control lever, and pedal for a short while until the engine has cooled down.

**IF YOU HAVE OBSERVED THESE INSTRUCTIONS DURING
THE RUNNING-IN PERIOD YOU CAN THEN USE YOUR
MINI-MOTOR WITHOUT ANY SPECIAL PRECAUTION
AFTERWARDS.**

BARNSTONERS.CO.NZ

CARBURETTOR

Adjustments to the mixture may be required to suit varying climates. For cold climates a richer setting of the carburettor is obtained by substituting the existing jet "V" (Fig. 7) by a bigger jet. The size of the jet is marked on the outside. If only a minor adjustment is needed, as for instance, when changing from Summer to Winter conditions, it can be obtained by turning the air intake "W" in the direction of the arrow marked "Rich."

A weaker mixture may be needed in a warmer climate and is obtained either by substituting the existing jet by a smaller one, or again for a minor adjustment, by turning the air intake in the direction of the arrow marked "weak."

Too rich a mixture is indicated by a pronounced tendency for the engine to four-stroke at slow speeds, or even with an extremely rich mixture at full throttle. (A two-stroke engine, such as the Mini-motor, is said to "four-stroke" when the exhaust note becomes staccato and uneven.)

Running on too rich a mixture fouls the insulator around the central electrode of the sparking plug which may result in its becoming unservicable.

Too weak a mixture is indicated by a tendency to run erratically at full throttle (the exhaust note undulates) or, by poor pulling and the fact that the highest speed is not obtainable at the full throttle opening, but with a somewhat smaller opening of the speed control lever.

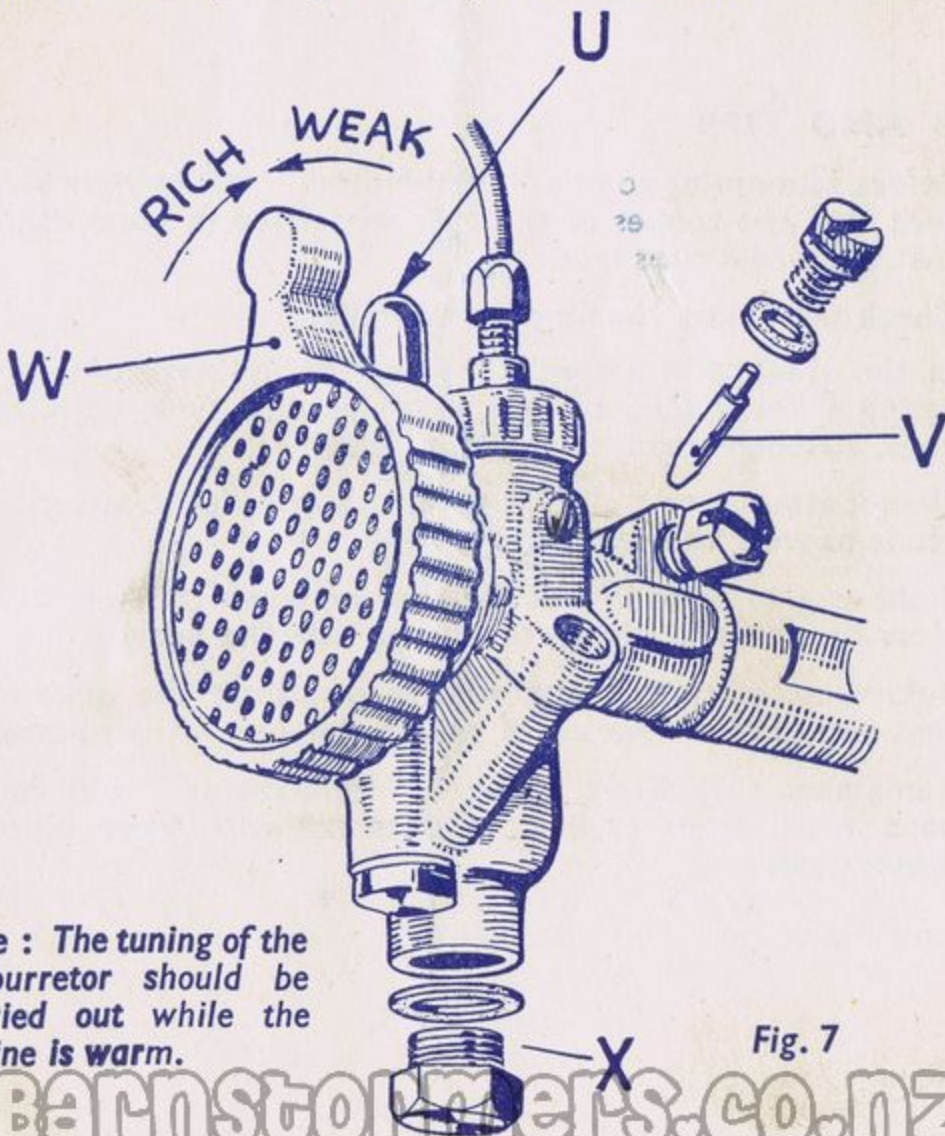

Note : The tuning of the carburettor should be carried out while the engine is warm.

Fig. 7

FLYWHEEL MAGNETO

It is advisable that all adjustments to the magneto be carried out either by a Mini-motor Agent or by a similarly experienced mechanic, and it is to such as these that the following paragraphs are addressed.

- (1) Check, and if necessary, readjust the contact breaker points every 3 months.

The contacts should be cleaned by inserting a dry smooth piece of paper between them and withdrawing same with the contacts in the normally closed position.

Do not allow the engine to run with oil or petrol on the contacts or they will burn and blacken. If this should occur, lightly polish with a magneto file or piece of smooth emery cloth.

- (2) Moisten the cam lubricating pad with a few drops of thin oil every 5,000 miles.
- (3) Occasionally clean the high tension lead and insulator, examine for cracks or other damage, and replace if necessary.
- (4) If the magneto requires any attention beyond replacement of the contact breaker points or condenser it is recommended that the complete instrument should be sent to your local agent or Mini-Motor Ltd. for servicing.

HINTS AND TIPS

- (1) Before attempting to fit a "Mini-Motor" unit to your bicycle make sure that the spokes of the rear wheel are in good condition and that the wheel runs true.
- (2) Check and adjust your brakes carefully.
- (3) In the absence of a special "power drive" type of tyre we advise fitting a heavy (i.e., tandem type) pattern tyre, with, for preference, a ribbed tread, to the rear wheel.
- (4) Do not attempt to "slip" the drive control lever, as such treatment tends to wear the rear tyre.
- (5) If the engine races in wet weather or when climbing a steep hill, close the throttle slightly and assist with the pedals.
- (6) Before attempting in any way to dismantle the unit, make sure that you have a new set of gaskets for use when re-assembling.
- (7) Remember that while fitting a "Mini-Motor" will remove the hard work from cycling, it does *not* turn your bicycle into a motorcycle.

GENERAL MAINTENANCE

EVERY 1,000 MILES

(A) Remove the sparking plug, cylinder head and exhaust silencer. Carefully scrape the carbon deposit from the inside of the cylinder head and from the piston top, using, for example, the blunt side of a penknife or similar article, care being taken not to scratch the surface of the aluminium parts. Also clear the carbon from the two small recesses on the sides of the piston crown.

Remove the decompressor valve, clean and reseat if necessary. Make sure that the decompressor is tightly screwed into the cylinder head, always using a new copper and asbestos washer when refitting the decompressor.

The cylinder will also have a carbon deposit near the cylinder head joint corresponding to the aforementioned recesses in the piston. These carbon deposits should also be carefully removed.

Now, turn the engine until the piston is at its lowest position and, looking into the exhaust port (Fig. 8), you will find that it

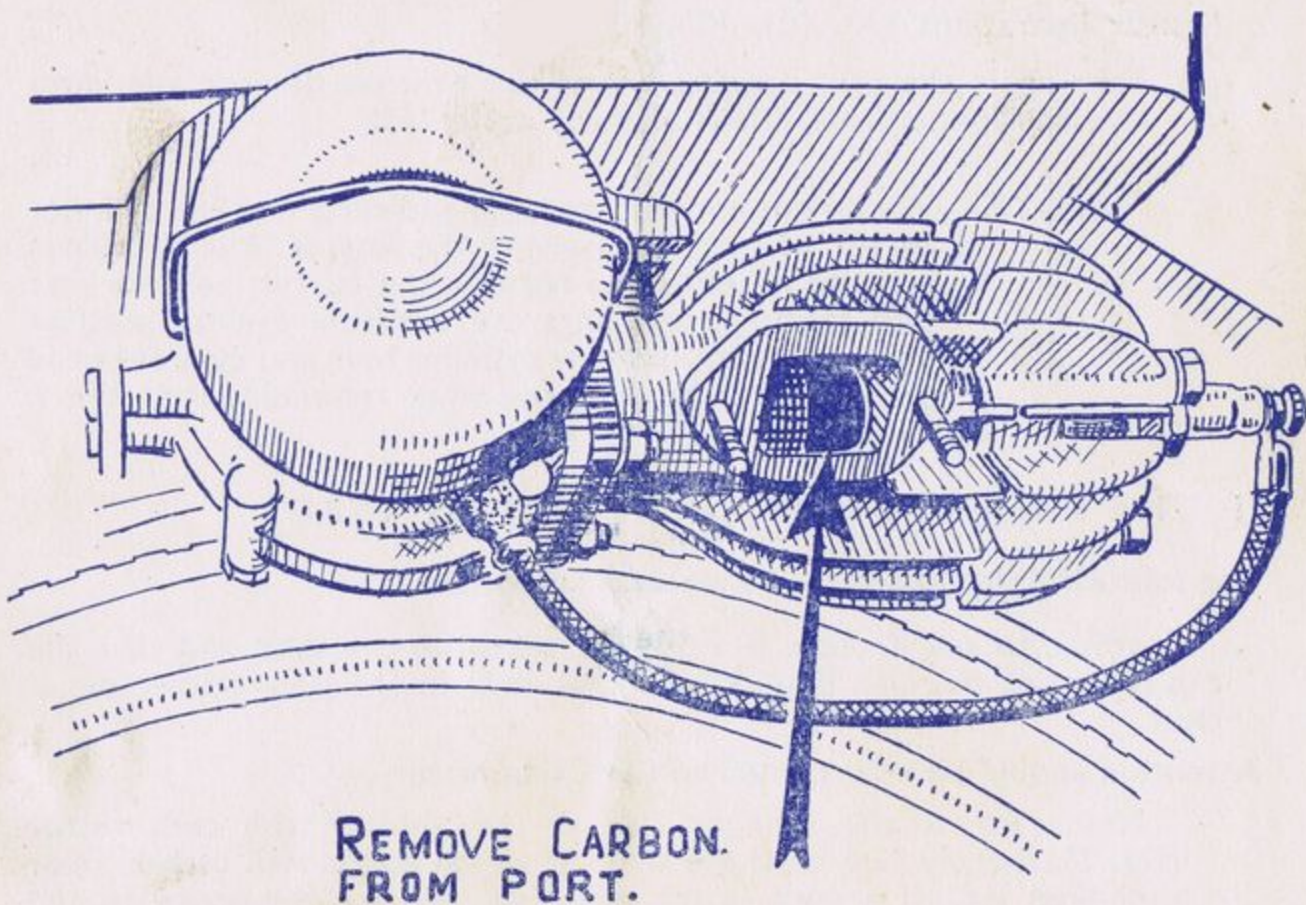

Fig. 8

probably has a carbon deposit around the edges. Scrape away this deposit. Now wipe the inside of the cylinder with a clean rag. To remove any particles of carbon which may have fallen in, blow through the exhaust port with a hand pump. When you are satisfied that the inside of the cylinder is clean, carefully clean the contact surfaces of both cylinder and head and then make a joint with gold-size, shellac or similar compound, and a new gasket.

When replacing the cylinder head tighten the three securing bolts progressively, then check again for tightness when the engine is warm after restarting, when your service work has been completed.

- (B) Oil the Control Cables.
- (C) Looking at the bicycle from the rear, check that the roller rests well on the centre of the tyre. If this is not so, loosen Bolt "C" of the sliding hinge and centralise the Unit. Make sure to retighten the bolt again. Remove all dirt from between the roller fins (if finned type is fitted).
- (D) Turn off petrol tap and remove screwed Plug "X" (Fig. 7) from the bottom of the carburettor float chamber. Turn on the petrol again momentarily to wash dirt out of the float chamber and replace screwed plug.
- (E) Check tightness of all nuts and bolts.

EVERY 2,000 MILES

Repeat operations (A), (B), (C), (D), (E).

- (F) Take apart the two components of the exhaust silencer and clean the interior surfaces, inlet holes and outlet slot.

NOTE.—We do not normally recommend removing the cylinder barrel when decarbonising the engine, but if it does become necessary to remove the barrel, be sure that two spare piston rings are available against possible breakage, also that new cylinder base and cylinder head gaskets are to hand for use when rebuilding the engine.

IF THE ENGINE STOPS OR WILL NOT START

The following checks should be made in succession :

Examine to see if there is sufficient petrol in the tank and that the cap is turned on, also that the air vent hole in the petrol filler cap is clear.

Attention should be now turned to the Carburettor.

First depress the plunger "U" at the side of the carburettor (Fig. 7), sharply two or three times ; which action will usually clear a choked jet. If a cure is not effective, remove the screw in the side of the carburettor which allows the removal of the jet "V" (Fig. 7).

Taking the jet between the thumb and forefinger, look through the hole which runs the whole length of it. This hole must be clear and round. If necessary it may be blown through or cleaned. If the jet is clean, before replacing it check that the petrol comes freely to the carburettor. Give two or three sharp strokes with the primer plunger "U" (Fig. 7) and you should see petrol gush from the well where the jet is inserted.

Then look into this well and you should see the petrol refilling it slowly.

If this is not the case it is shown that no petrol reaches the carburettor jet. Therefore, turn petrol tap off, remove the banjo union of the petrol pipe from the top of the carburettor and turn on the petrol momentarily to see if the pipe is clear. Within this banjo you will find the gauze filter which should be cleaned, and also it should be observed if the hole in the top of the float chamber through which the petrol flows is clear. To do this it will be necessary to remove the carburettor from the machine by loosening the clamp screw and pulling the carburettor off the inlet pipe. Fig. 7.

To clear this hole blow through it with a hand pump or with the mouth. Do not, on any account, endeavour to pass wire through or you may damage the float needle below this hole. If petrol will not flow through the petrol pipe the stoppage is within the tank or pipe, and these parts should be blown through with a hand pump.

When replacing the carburettor, before tightening the clamp screw, make sure that the float chamber is vertical.

If this examination has been completed but your engine yet will not start, the ignition system must be tested. First remove the sparking plug. If it is wet with petrol, this is additional evidence that mixture is reaching the cylinder. Wipe the sparking plug clean and proceed as follows :

To check the sparking plug lift the engine from the tyre by means of the handlebar control (drive control lever). Unscrew the sparking plug but keep it connected to the H.T. lead and place it against the cylinder.

Remove the cover of the flywheel and give the flywheel a series of sharp anti-clockwise turns. A spark should occur between the sparking plug points. (If the spark occurs inside the body of the plug the sparking plug should be changed and a further attempt made.) If there is no spark, try again with a spare plug, and if there now is a spark you have cured the trouble.

If no spare plug is available remove the H.T. lead from the sparking plug and hold the lead by the rubber portion so that the terminal is about $\frac{1}{8}$ in. away from the cylinder. Turn the magneto sharply, as mentioned above, to observe if a spark occurs between the H.T. lead and the cylinder. If a spark is seen, a test should be made with a new plug (see above).

If no spark is obtained then the fault is with the H.T. lead or the magneto.

The H.T. lead should first be examined and if the insulation is cracked or damaged it should be replaced and again a further check for spark made.

Where, however, the trouble appears to be with the magneto you must have recourse to the nearest Mini-Motor Dealer.

SHOULD YOUR ENGINE RUN BADLY

- (a) If it runs erratically or mis-fires it is probable that the carburettor is delivering a weak mixture. Turn the air intake "W" (Fig. 7) in the direction of the arrow "rich" and check for an improvement.
If you are already running with the control in the "rich" position a larger jet is required.
- (b) If the engine loses power and the exhaust becomes very quiet, the cause may be a choked exhaust port (see maintenance A) or a choked silencer (see maintenance F).
- (c) If the engine shows a poor compression when turned, it may be that the cylinder head is leaking, or that the sparking plug is not tight, or that the piston rings need to be replaced, or if you have covered a great mileage the cylinder may need re-boring and a new piston fitted.
- (d) The roller may be slipping on the tyre because the pressure is not adequate or the tyre is not pumped very hard (see "Adjustment of roller pressure," page 6), or because the roller fins are choked with mud.

MINI-MOTOR (Gt. Britain) LIMITED
PURLEY WAY, CROYDON

Telephone No. CRO. 6539

Telegrams: MINI, CROYDON

Cables: MINI, CROYDON, ENGLAND

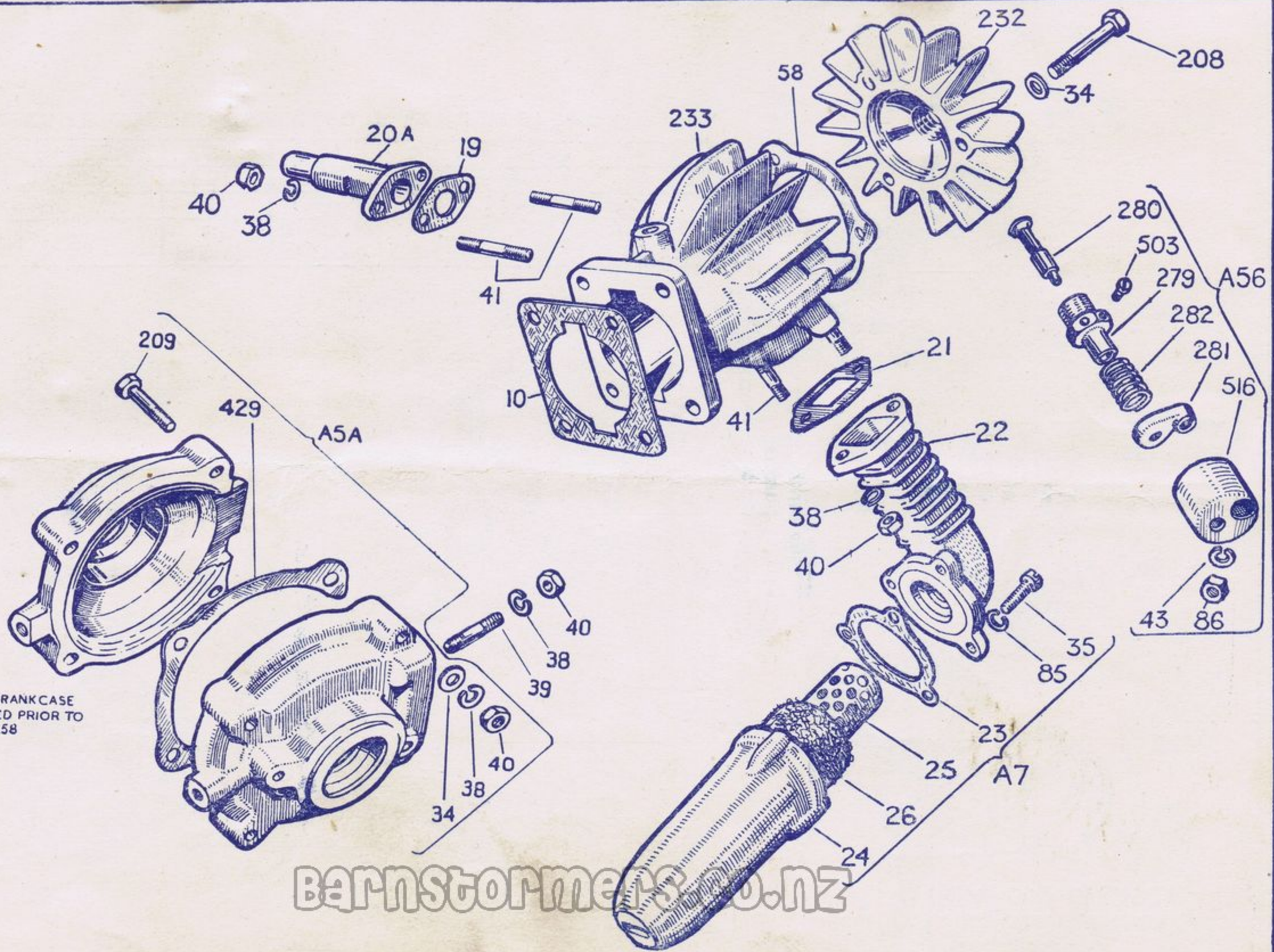

A5 STUDDED CRANKCASE
ASSEMBLY FITTED PRIOR TO
ENGINE N° 15258
{ 237 STUD
{ 236 GASKET

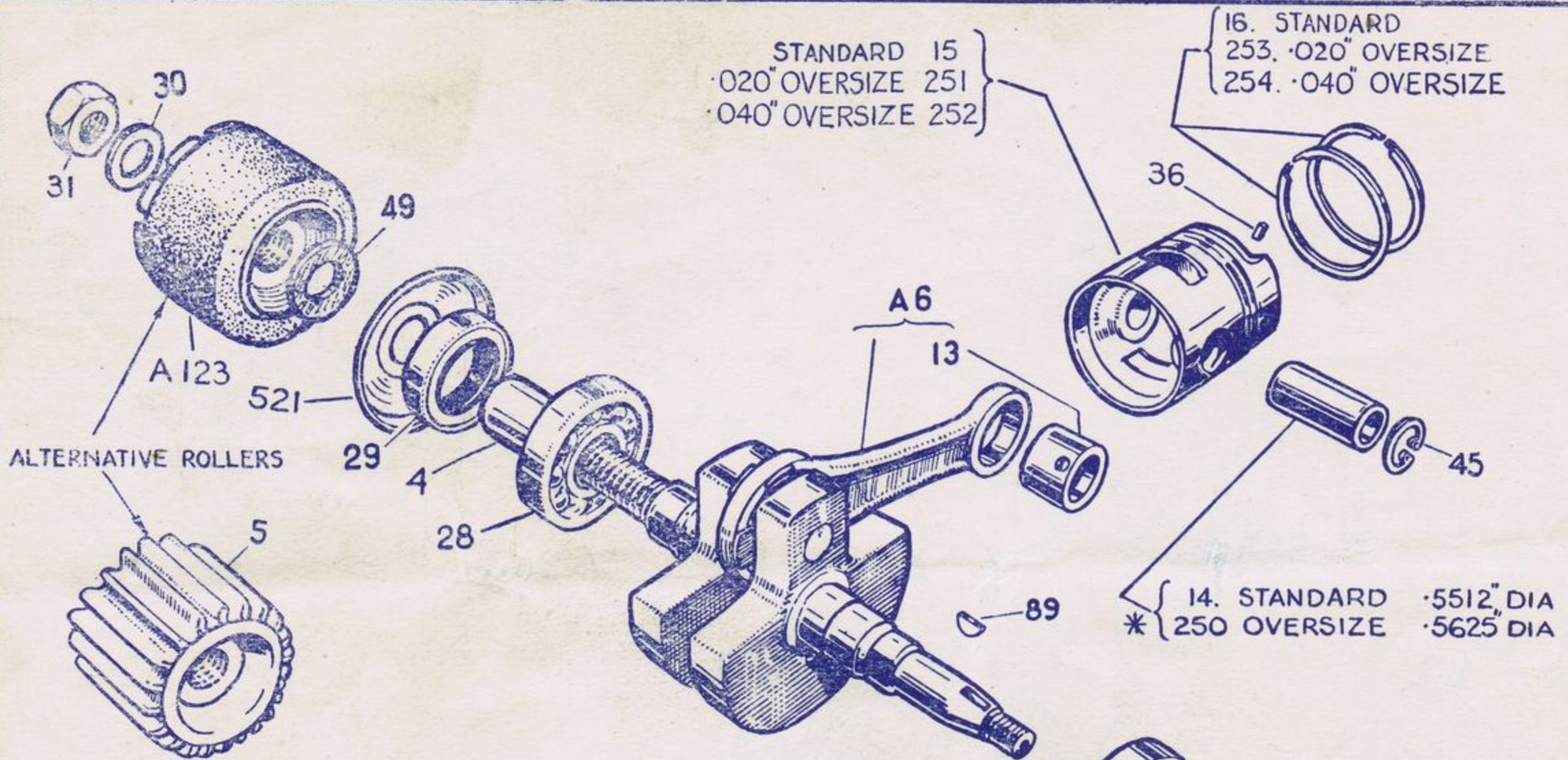

PISTON ASSY	PISTON N ^o	PISTON RING N ^o	CIRCLIP N ^o	PEG N ^o	GUDGEON PIN N ^o
A3 STANDARD	15	16	45	36	14
A74 .020" OVERSIZE	251	253	45	36	14
A75 .040" OVERSIZE	252	254	45	36	14

250 OVERSIZE GUDGEON PIN USED IF REQUIRED. :-*

BARNSTORMERS.CO.NZ

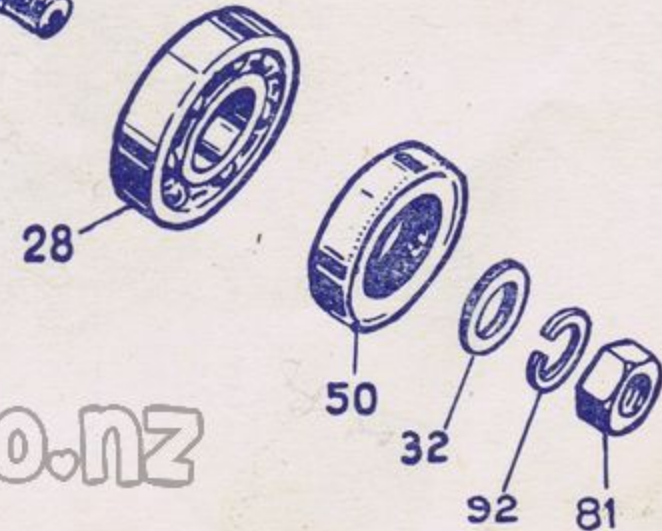

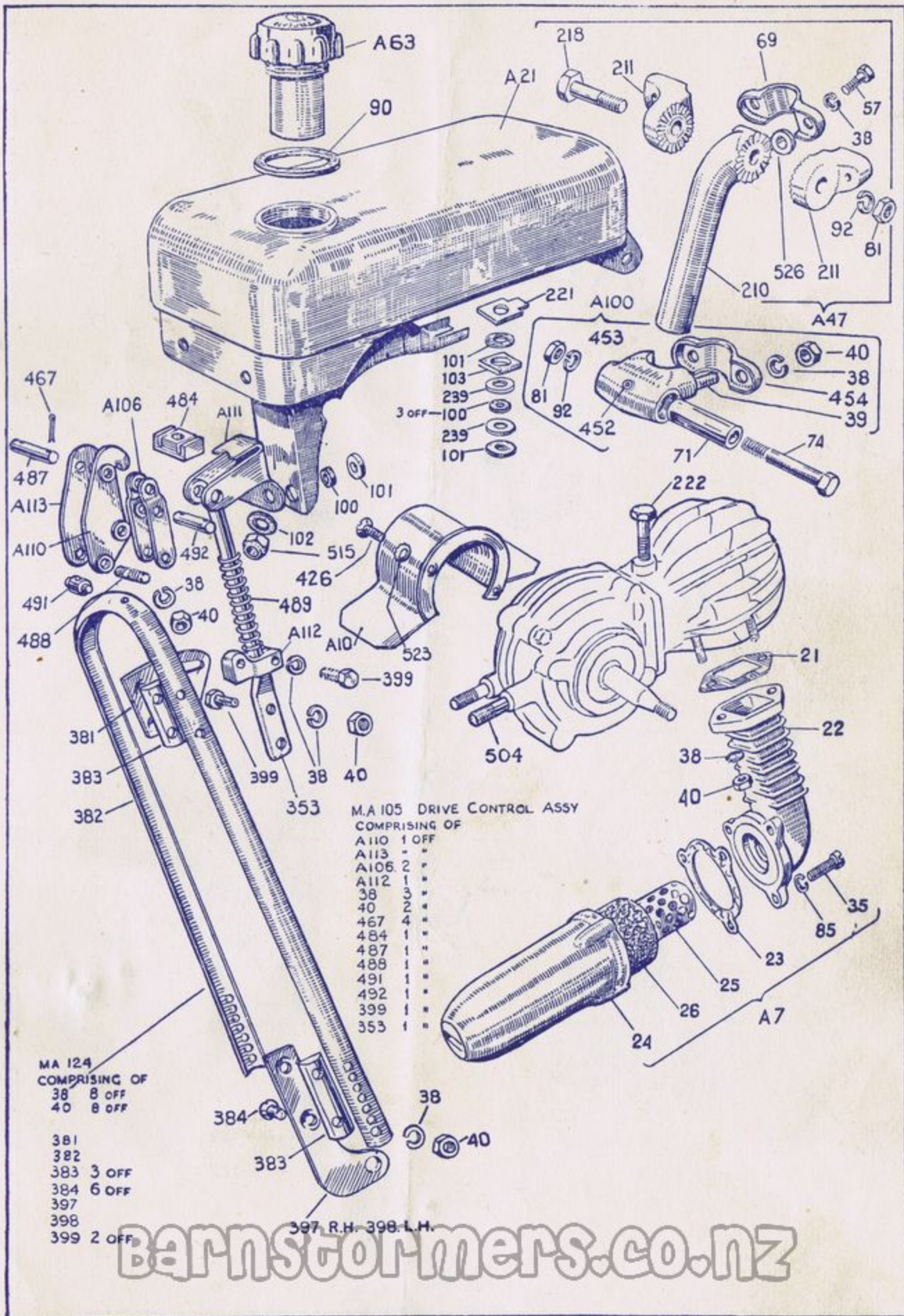

- M.A 105 DRIVE CONTROL ASSY
 COMPRISING OF
- A110 1 OFF
 - A113 -
 - A106 2 "
 - A112 1 "
 - 38 3 "
 - 40 2 "
 - 467 4 "
 - 484 1 "
 - 487 1 "
 - 488 1 "
 - 491 1 "
 - 492 1 "
 - 399 1 "
 - 353 1 "

- MA 124
 COMPRISING OF
- 38 8 OFF
 - 40 8 OFF

- 381
- 382
- 383 3 OFF
- 384 6 OFF
- 397
- 398
- 399 2 OFF

397 R.H. 398 L.H.

BARNSTORMERS.CO.NZ

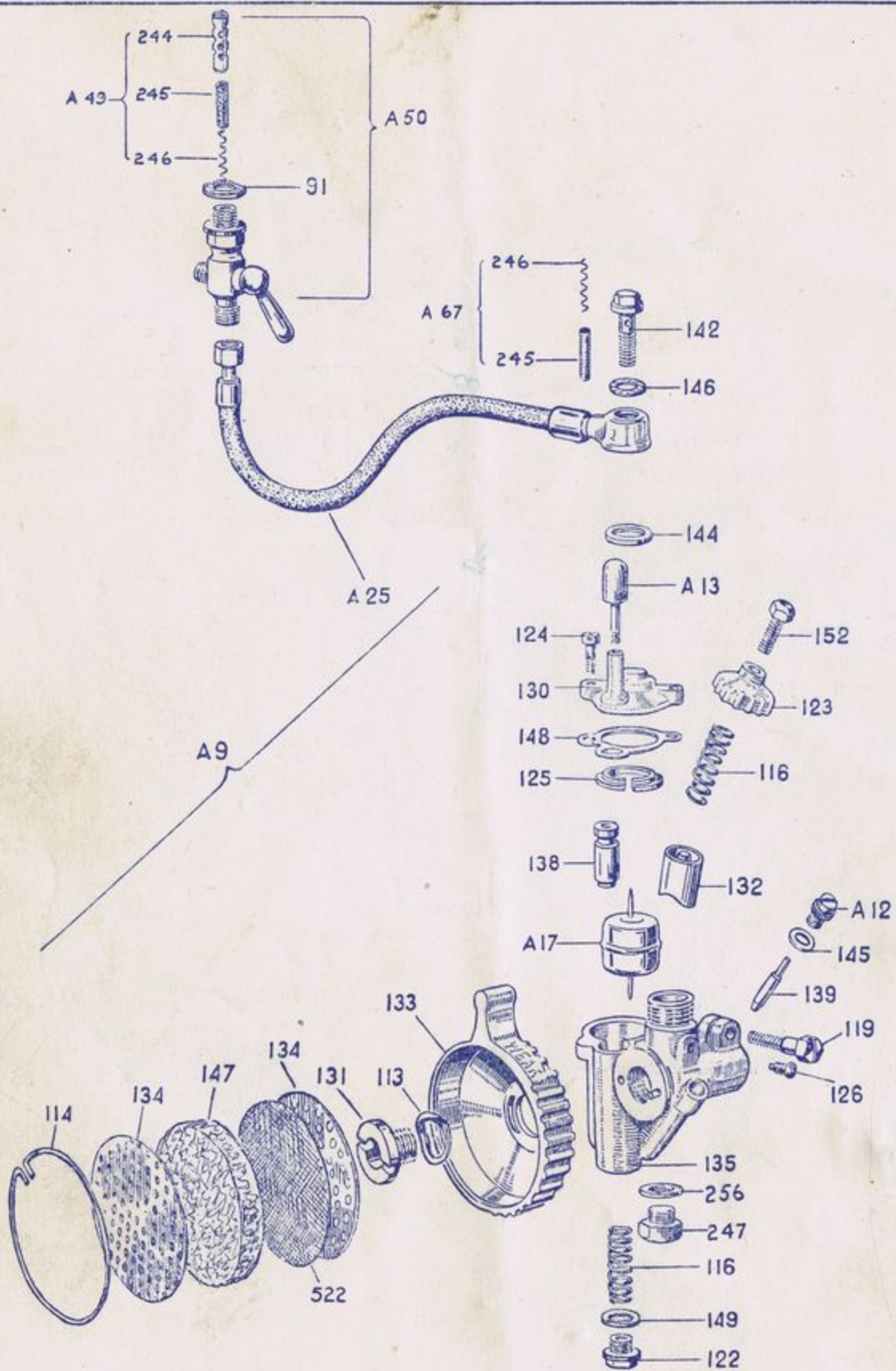

BARNSTORMERS.CO.NZ

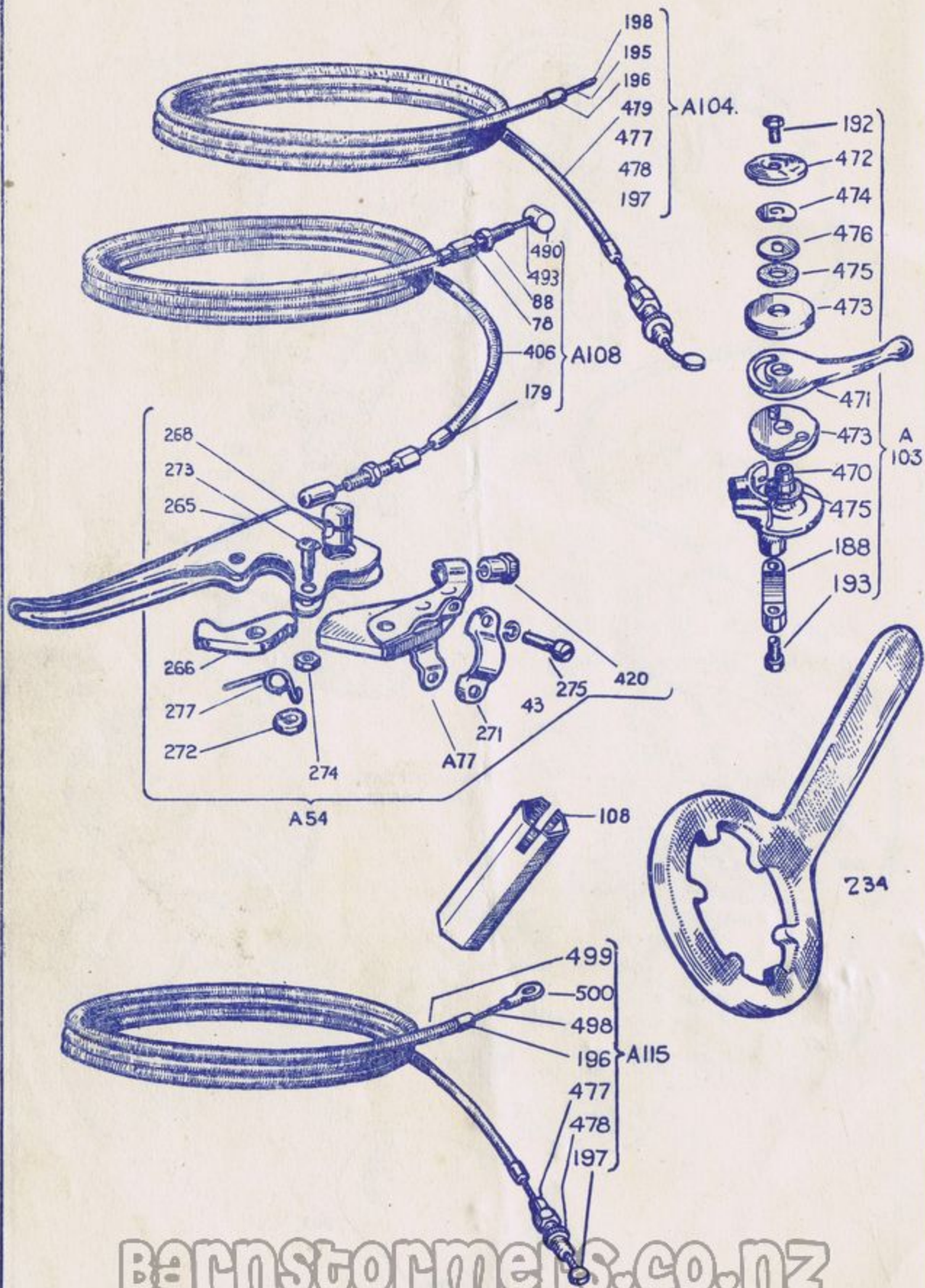

Barnstormers.co.nz