

SERVICE **WIPAC** MANUAL

THE WIPAC GROUP
BUCKINGHAM BUCKS

Barnstormers.co.nz

The logo for WIPAC, featuring the word "WIPAC" in a stylized, outlined font. The letters are bold and blocky, with a horizontal line above the "W" and "I".

Number 2 Manual

dealing with the servicing
and maintenance of

Electrical

with

MOTOR CYCLE & CYCLE MOTOR APPLICATIONS

This manual is designed as a loose leaf
binder to simplify additions or
deletions and will be kept up to date
for you upon receipt of your name
and address











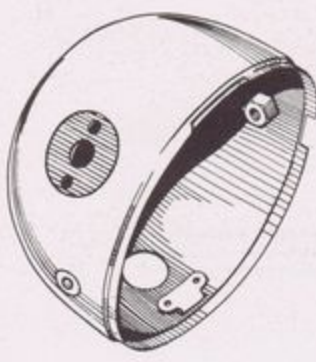
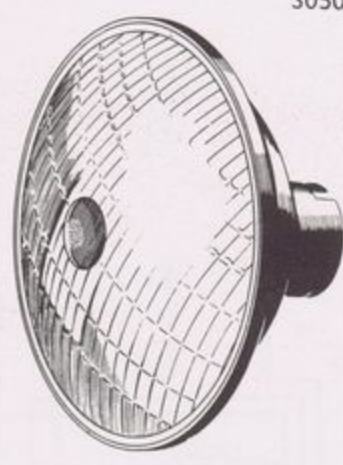
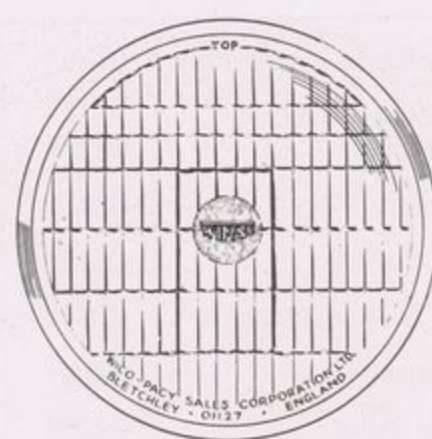

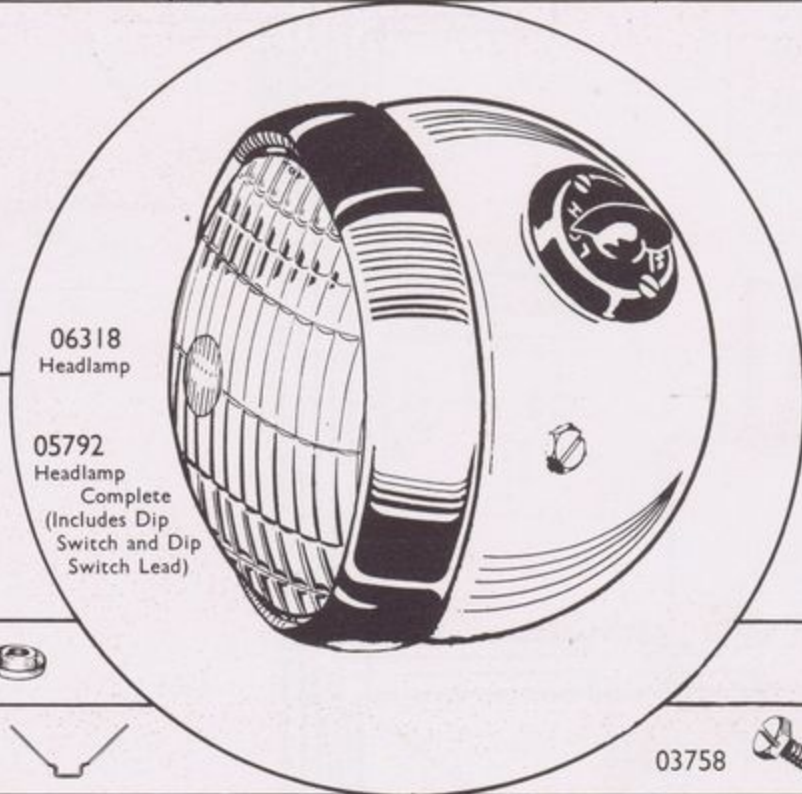
PRICE

TWO SHILLINGS & SIXPENCE

THE **WIPAC** GROUP

BLETCHLEY

ENGLAND

 <p>05740 Lamp Body Unit</p>	<p>S0506</p>  <p>Reflector and Glass Set</p>	<p>01127</p>  <p>Headlamp Glass</p>	
<p>00915</p>  <p>Bulb Holder Unit</p>	 <p>06318 Headlamp</p> <p>05792 Headlamp Complete (Includes Dip Switch and Dip Switch Lead)</p>		 <p>03561 Rim</p>
<p>00608 Connector (Single)</p> 			 <p>06195 Dip Switch</p>
<p>04938 Pilot Bulb Holder</p> 			 <p>03586 Rim Locking Screw</p>
<p>06525 Reflector Clips Box of 3</p> 			<p>03758</p>  <p>Headlamp Fixing Bolts & Washers</p>
 <p>06588 Switch Cover and Knob Group (Lights)</p>			<p>06587 Switch Body Unit (Used on Both)</p> 
<p>S0526 (Blue) Plug Unit</p>			<p>02427 Main Harness 05749 Dip Switch Harness</p>
<p>S0525 (Black) Plug Unit</p>			



WIRING WIPAC DIAGRAM









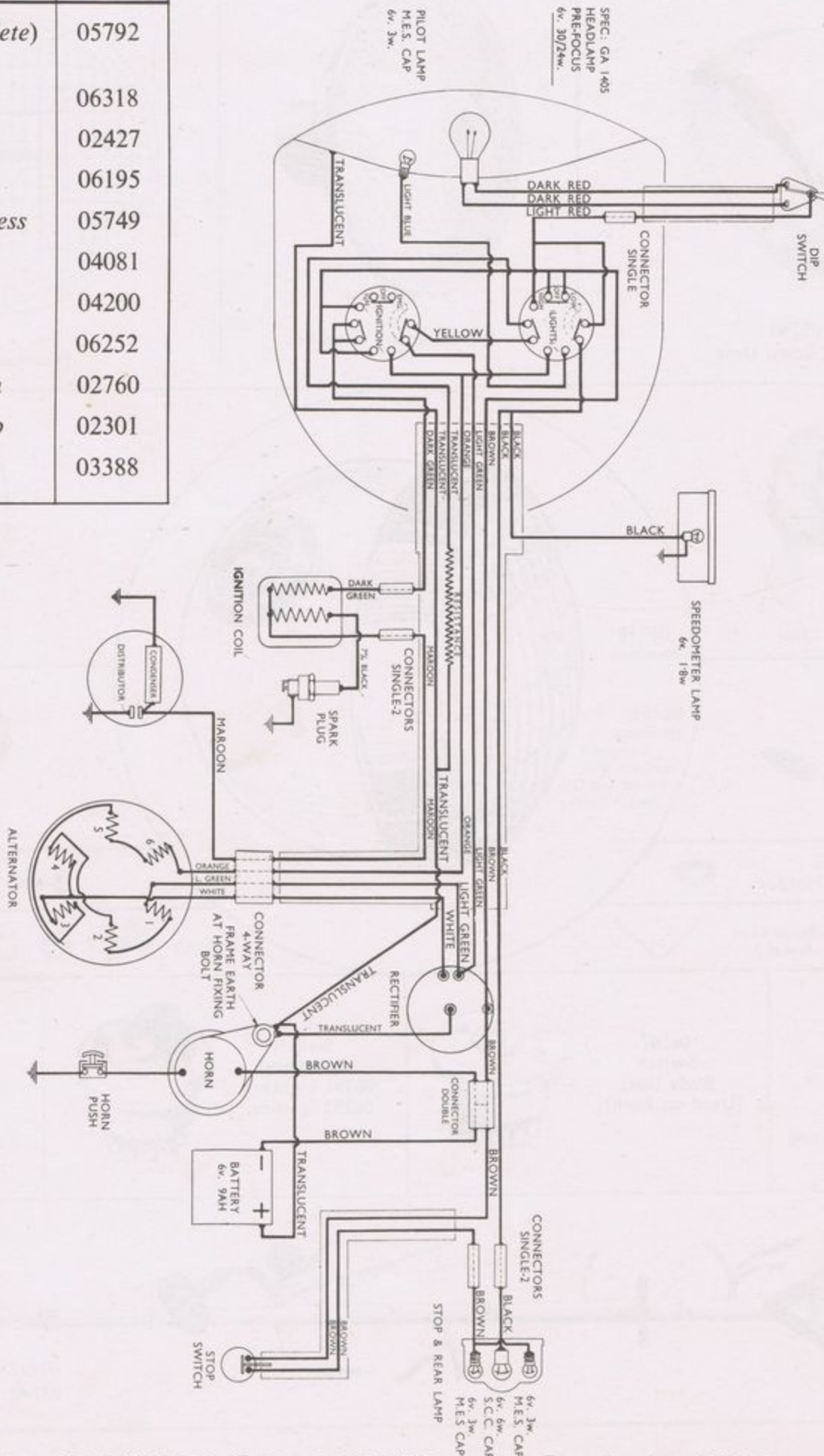

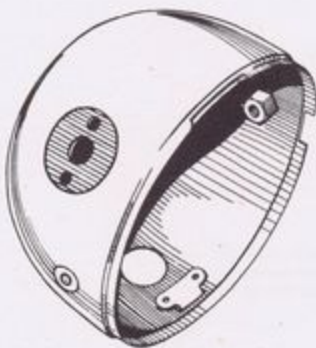
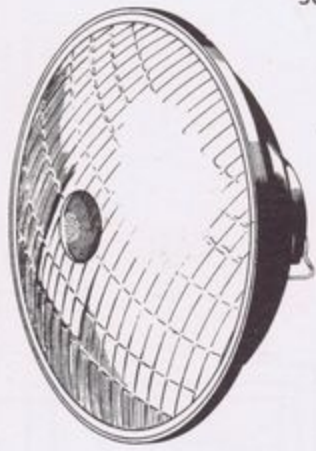
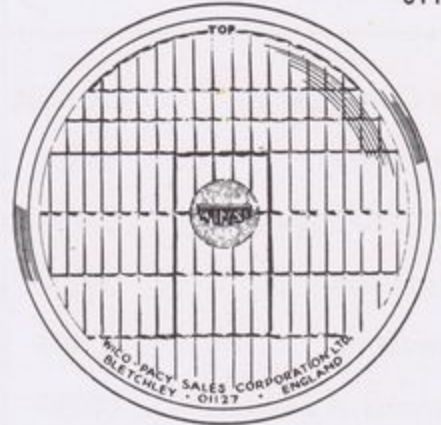

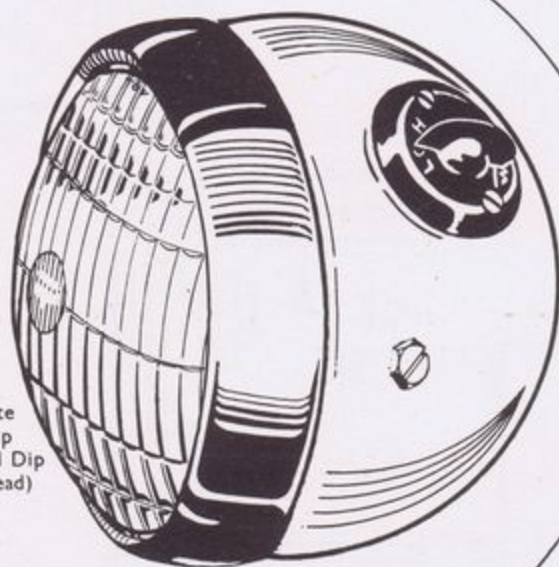
ARIEL model "Colt" L.H.

MODELS PRODUCED FROM AUGUST 1955 TO JULY 1956

THE WIPAC GROUP · BLETCHLEY · ENGLAND

SPARES UNITS	PART No.
Headlamp (complete)	05792
Headlamp (less harness)	06318
Harness	02427
Dip Switch	06195
Dip Switch Harness	05749
Alternator	04081
Distributor	04200
Rectifier	06252
Coil—6v. Ignition	02760
Stop & Tail Lamp	02301
Stop Switch	03388

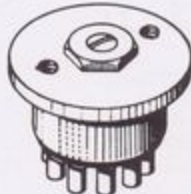

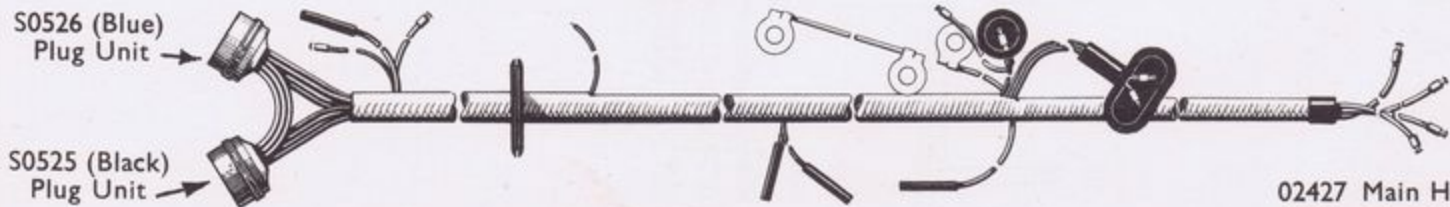
 <p>05740 Lamp Body Unit</p>	 <p>S0505 Reflector and Glass Set</p>	 <p>01127 Headlamp Glass</p>
 <p>06795 Bulb Holder Unit (includes 4 connector plugs)</p>	 <p>06317 Headlamp</p> <p>02404 Headlamp Complete (Includes Dip Switch and Dip Switch Lead)</p>	 <p>03561 Rim</p>
 <p>00608 Connector (Single)</p>		 <p>06195 Dip Switch</p>
 <p>04938 Pilot Bulb Holder</p>		 <p>03586 Rim Locking Screw</p>
 <p>06525 Reflector Clips Box of 3</p>		 <p>03758 Headlamp Fixing Bolts & Washers</p>
 <p>06588 Switch Cover and Knob Group (Lights)</p>		 <p>06587 Switch Body Unit (Used on Both)</p>
 <p>06589 Switch Cover and Knob Group (Ignition)</p>		
 <p>S0526 (Blue) Plug Unit</p> <p>S0525 (Black) Plug Unit</p> <p>02427 Main Harness 05749 Dip Switch Harness</p>		



WIRING WIPAC DIAGRAM

B.S.A. model C.10.L. MODELS PRODUCED FROM AUGUST 1955

THE WIPAC GROUP · BLETCHLEY · ENGLAND

EQUIPMENT	PART No.
Set Complete	G.A.1406
Alternator	04081
Coil—6V. Ignition	02766
Distributor	04200
Headlamp	02404
Harness & Lead Set	06293
Dip Switch	06195
Stop & Rear Lamp	02300
Stop Switch	03400
Rectifier	02798

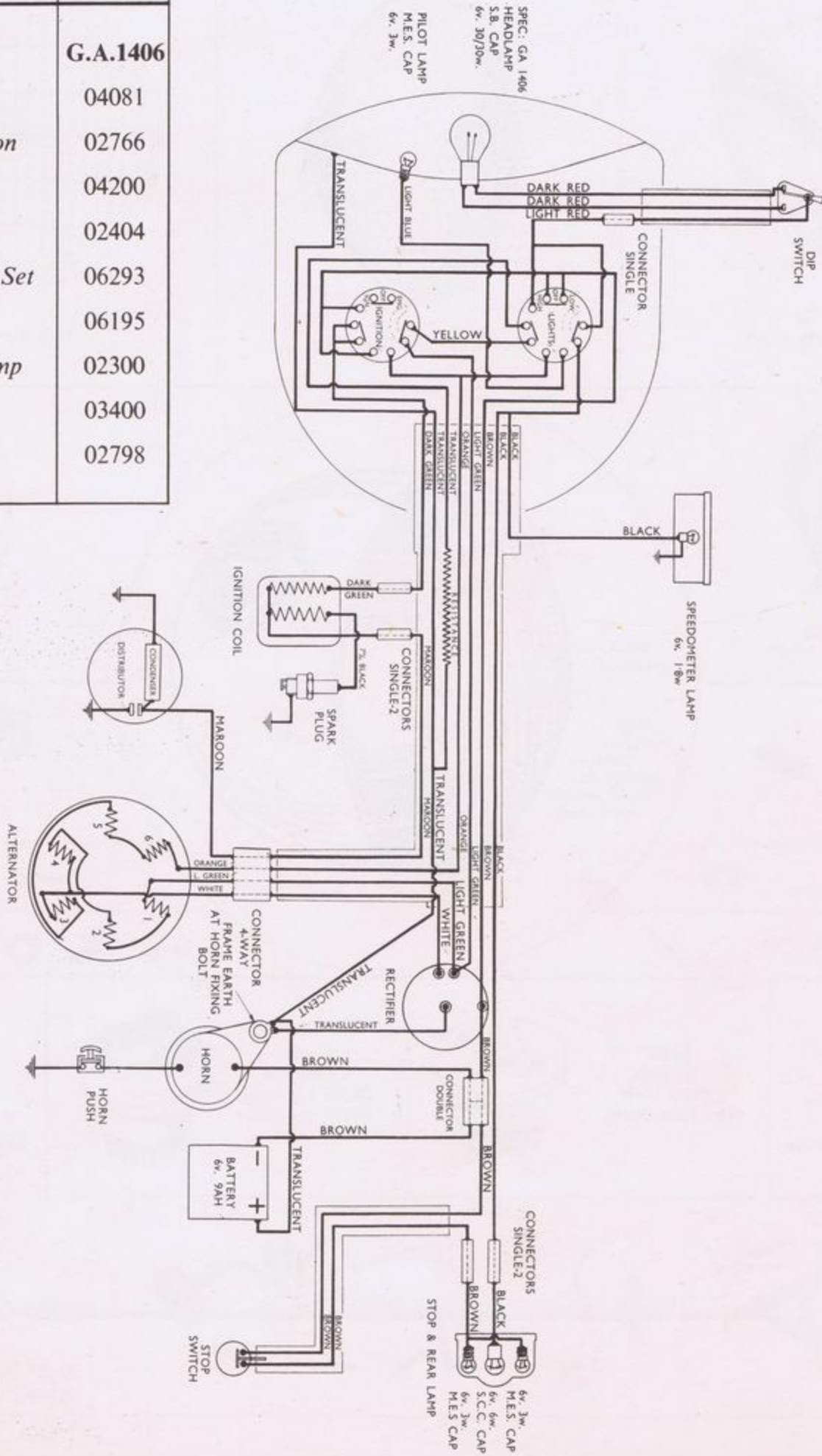

WIPAC

AS FITTED TO THE
B.S.A. BANTAM, 125 c.c.
MOTOR CYCLE, MODEL D.1

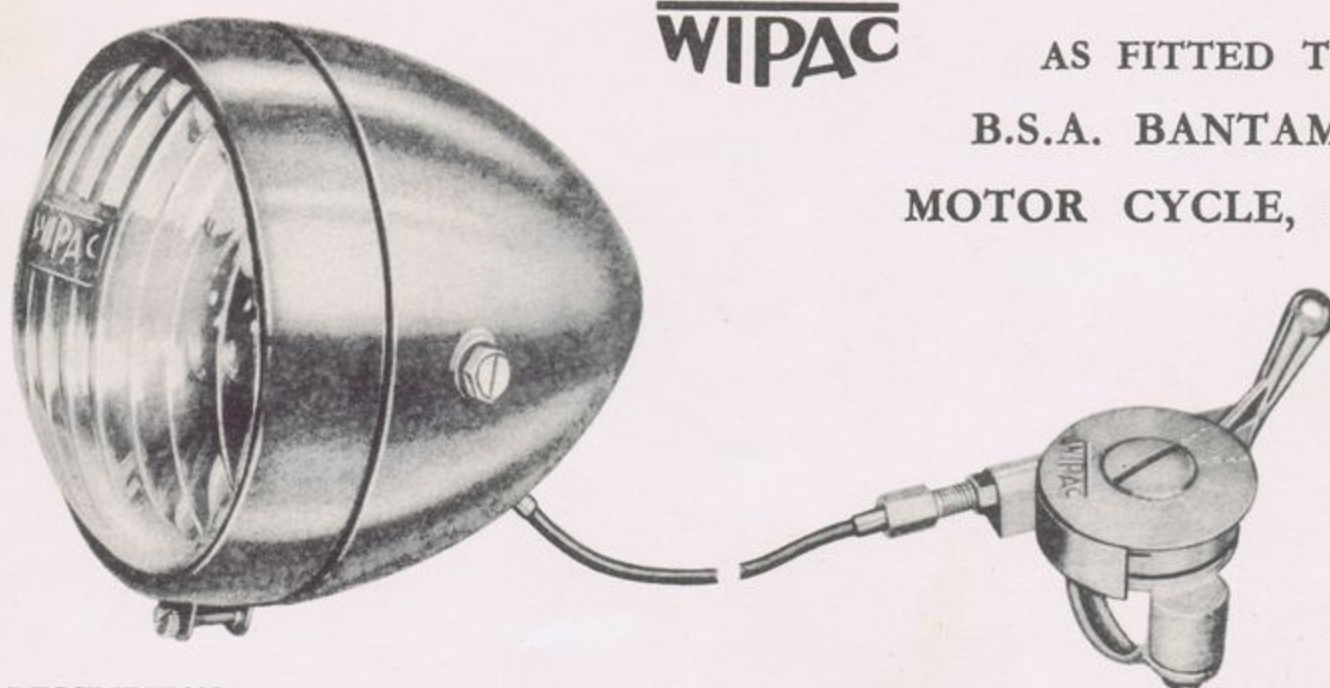

DESCRIPTION

The Wipac Lamp Set is of sturdy design, light in weight and completely weather-proof. The switch is totally enclosed in the body of the lamp, which considerably reduces the possibility of the contacts being affected by the weather, and is controlled by means of a Bowden cable with a lever fitted in a convenient position on the handlebars. In other words "Your Light control is always at your finger-tips." The switch has four movements, providing Parking, Head Dipped, Head Full On and Off.

GENERAL INFORMATION

Head Lamp. The reflector and bulb assembly bracket is housed in the front rim and to obtain access to the head-lamp bulbs loosen the screw situated at the bottom of the rim of the lamp and lift the rim outwards and upwards. Next, to remove the bulb assembly bracket, bend the small tab which projects from the base of the reflector downwards. The bracket can then be removed by turning it anti-clockwise, both the main and parking bulbs are now easily accessible. When replacing the main bulb be sure that the word "top" on the bulb is uppermost.

If the bulb is not marked, assemble as illustrated :—
The correct focus has been incorporated in the design of the head lamp and therefore no provision for adjustment has been necessary.

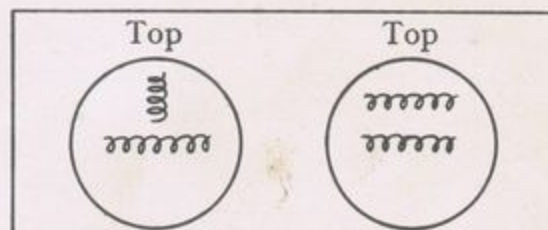

Correct way to fit double-filament bulbs.

Tail Lamp. To remove the rim of the lamp, turn the rim to the left, it can then be easily withdrawn. The bulb holder is of the bayonet pattern and the bulb is removed by the usual push-and-turn method.

Switching. Adjustment will rarely be necessary, but should the switch lever ever require adjustment to synchronise with the switch itself it can easily be carried out by adjusting the screw which connects the Bowden cable to the lever assembly. First of all loosen the adjusting screw locknut and then turn the screw in or out to the required position. It is best to carry out this adjustment with the engine running.

Parking Battery. This is a 3-volt bicycle battery, type 800. To fit a new battery, hold it so that the vertical contact strip faces towards the lamp, the battery should then be positioned in the holding bracket in such a manner so that the vertical contact connects with the metal battery holder at the rear of the lamp, while the horizontal contact fits underneath its corresponding contact.

WIPAC
ELECTRICAL
EQUIPMENT

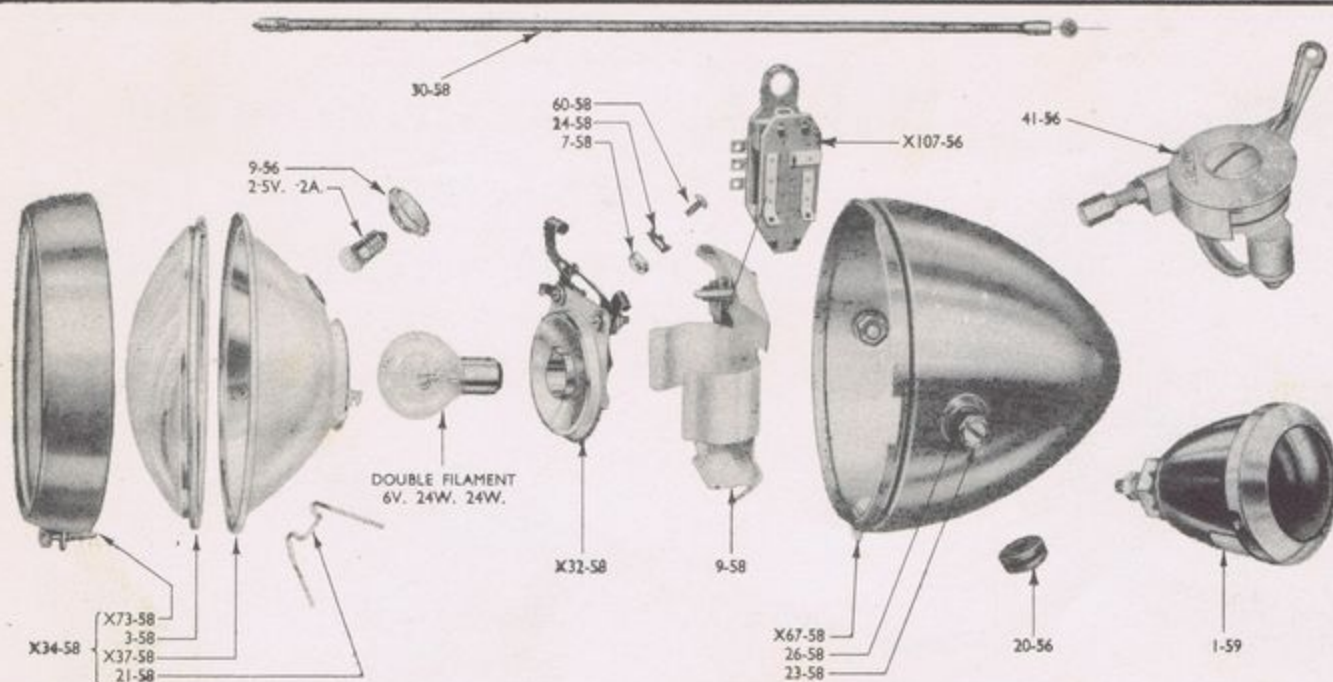

SPARE PARTS LIST

Part No.	Qty.	Description	Price		
			£	s.	d.
9-56	1	Pilot Bulb Holder		2	0
20-56	1	Grommet			6
41-56	1	Control Complete		3	9
X-107-56	1	Switch		10	6
1-58	1	Headlamp, Complete with Control Unit	3	10	0
3-58	1	Headlamp Glass		3	0
7-58	3	Battery Bracket Fixing Nut			2
9-58	1	Battery Bracket		5	0
21-58	3	Headlamp Reflector Retaining Wire			3
23-58	2	Headlamp Fixing Bolt			3
24-58	3	Battery Bracket Fixing Nut Lock Washer			2
26-58	2	Headlamp Fixing Bolt Lock Washer			2
30-58	1	Control Cable Complete		5	0
32-58	1	Headlamp Contact Unit		7	6
X34-58	1	Headlamp Front Unit	1	3	0
X37-58	1	Headlamp Reflector		12	6
60-58	3	Battery Bracket Fixing Screw			2
X67-58	1	Headlamp Body and Pivot Assembly		12	6
X73-58	1	Headlamp Front Rim Unit		7	6
1-59	1	Motor Cycle Rear Lamp Complete		9	6

Replacement Bulbs Headlamp Main Bulb (Double Filament) 6v. 24w. 24w.
Headlamp Pilot Bulb 2.5v., .2a.
Tail Lamp Bulb 6v. 3w.

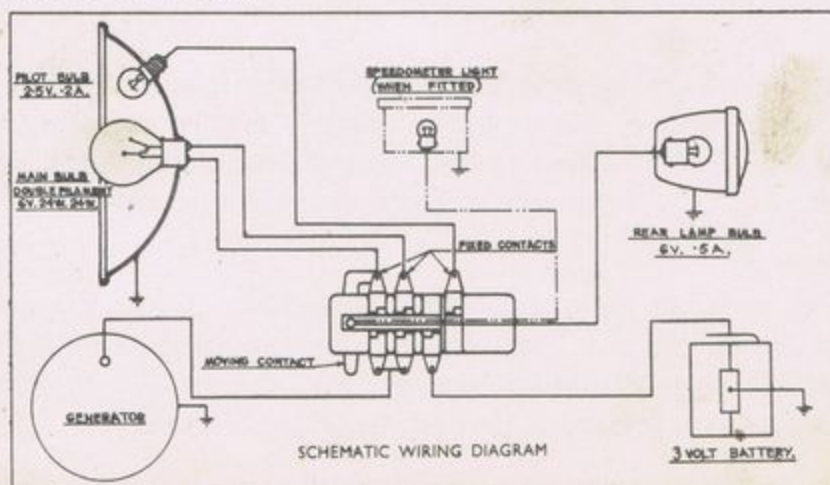

WIPAC

ELECTRICAL EQUIPMENT

HEADLAMP

TYPE 1-58

WITH REMOTE CONTROL
HANDLE BAR SWITCH

STANDARD EQUIPMENT ON:-

BSA BANTAM

125cc. MOTOR CYCLE
AND EXCELSIOR AUTOBYK



DESCRIPTION

The Wipac Lamp Set is of sturdy design, light in weight and completely weather-proof. The switch is totally enclosed in the body of the lamp, which considerably reduces the possibility of the contacts being affected by the weather, and is controlled by means of a Bowden cable with a lever fitted in a convenient position on the handlebars. In other words "Your Light control is always at your finger-tips." The switch has four movements, providing Parking, Head Dipped, Head Full On and Off.

SERVICING INSTRUCTIONS

Head Lamp. The reflector and bulb assembly bracket is housed in the front rim and to obtain access to the head-lamp bulbs loosen the screw situated at the bottom of the rim of the lamp and lift the rim outwards and upwards. Next, to remove the bulb assembly bracket, bend the small tab which projects from the base of the reflector downwards. The bracket can then be removed by turning it anti-clockwise, both the main and parking bulbs are now easily accessible. When replacing the main bulb be sure that the word "top" on the bulb is uppermost.

Tail Lamp. To remove the rim of the lamp, turn the rim to the left, it can then be easily withdrawn. The bulb holder is of the bayonet pattern and the bulb is removed by the usual push-and-turn method.

Switching. Adjustment will rarely be necessary, but should the switch lever ever require adjustment to synchronise with the switch itself it can easily be carried out by adjusting the screw which connects the Bowden cable to the lever assembly. First of all loosen the adjusting screw locknut and then turn the screw in or out to the required position. It is best to carry out this adjustment with the engine running.

Parking Battery. This is a 3-volt bicycle battery, type 800. To fit a new battery, hold it so that the vertical contact strip faces towards the lamp, the battery should then be positioned in the holding bracket in such a manner so that the vertical contact connects with the metal battery holder at the rear of the lamp, while the horizontal contact fits underneath its corresponding contact.

Never allow a discharge battery to remain in the Lamp, this will corrode and damage the Lamp Body.

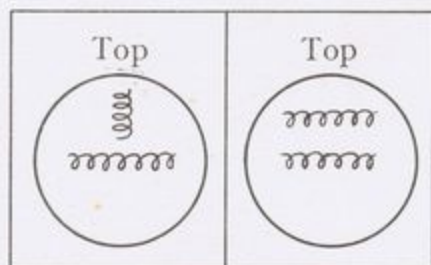

If the bulb is not marked, assemble as illustrated:—

The correct focus has been incorporated in the design of the head lamp and therefore no provision for adjustment has been necessary.

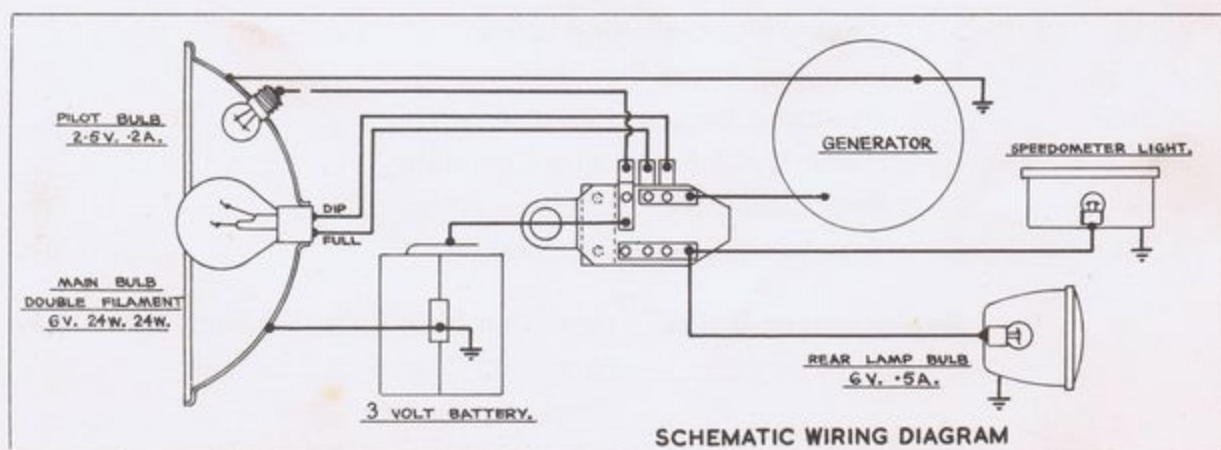

THE WIPAC GROUP — BLETCHLEY ENGLAND
NORTHERN AREA BRANCH AND SERVICE DEPOT 7 PARK SQUARE, LEEDS

SPARE PARTS LIST

HEADLAMP TYPE 1-58

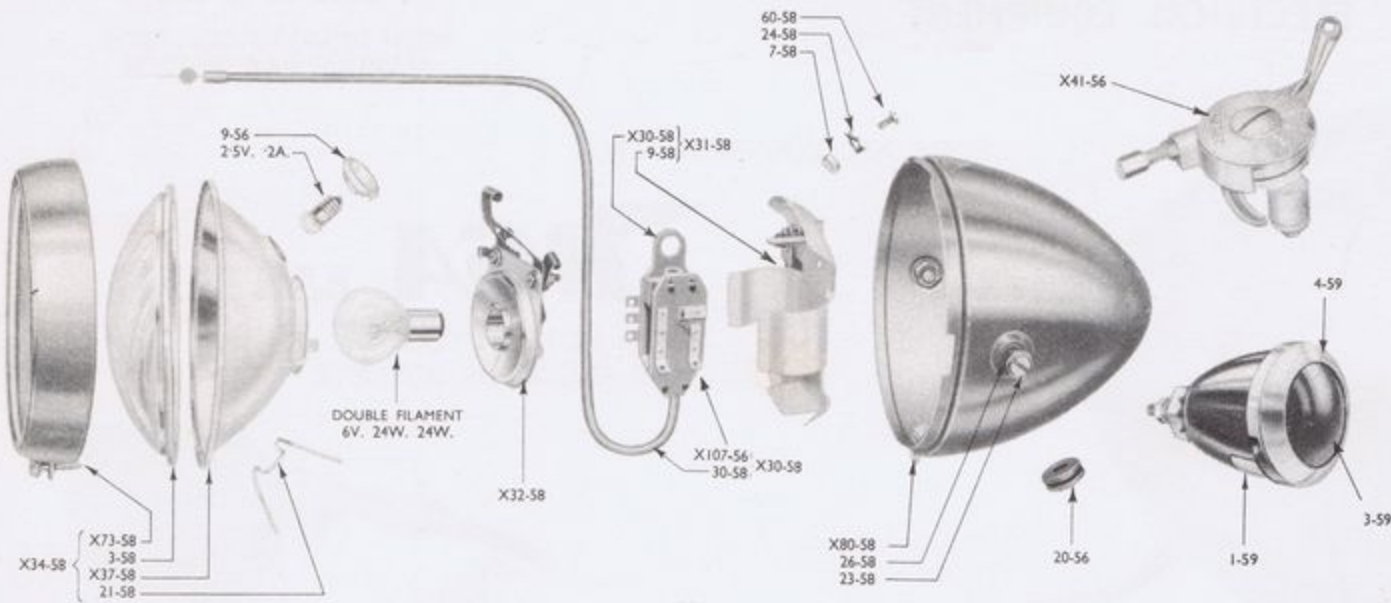

Part No.	Qty.	Description
9-56	1	Pilot Bulb Holder
20-56	1	Grommet
X41-56	1	Control Complete
X107-56	1	Switch Unit
1-58	1	Headlamp, Complete with Control Unit
3-58	1	Headlamp Glass
7-58	3	Battery Bracket Fixing Nut
9-58	1	Battery Bracket
21-58	3	Headlamp Reflector Retaining Wire
23-58	2	Headlamp, Fixing Bolt
24-58	3	Battery Bracket Fixing Nut Lock Washer
26-58	2	Headlamp Fixing Bolt Lock Washer
30-58	1	Switch Control Cable Complete
X30-58	1	Switch Complete with Control Cable
X31-58	1	Switch, Control Cable and Battery Bracket Complete
X32-58	1	Headlamp Contact Unit
X34-58	1	Headlamp Front Unit
X37-58	1	Headlamp Reflector
60-58	3	Battery Bracket Fixing Screw
X73-58	1	Headlamp Front Rim Unit
X80-58	1	Headlamp Body and Pivot Assembly
1-59	1	Motor Cycle Rear Lamp Complete
4-59	1	Rear Lamp Rim, Chromium Finish
3-59	1	Rear Lamp Glass (unbreakable)

Replacement Bulbs Headlamp Main Bulb (Double Filament) 6v., 24w. 24w.
 Headlamp Pilot Bulb 2.5v., .2a.
 Tail Lamp Bulb 6v. 3w.

BRITISH BUILT

BY THE WIPAC GROUP
 BARNSTONERS.CO.NZ

REF. D.59R

03672

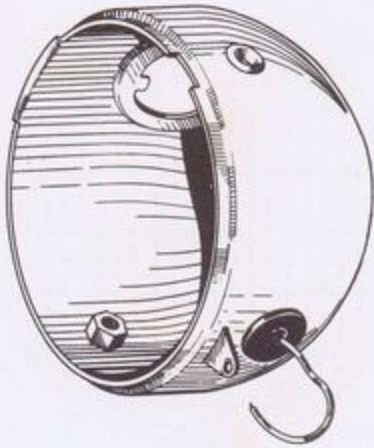

Lamp Body Unit

S0505



Reflector and Glass Set

01127

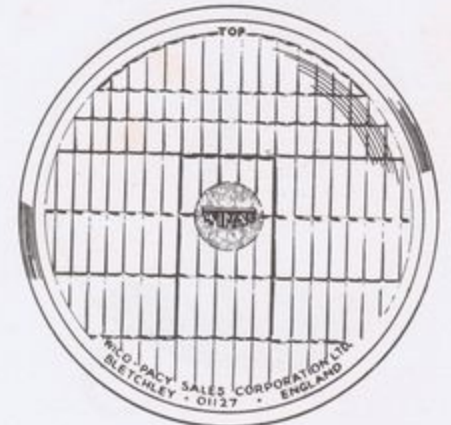

Headlamp Glass



06795
Bulb Holder Unit



03678
Battery Retaining Clip

04938
Pilot Bulb Holder



06525

Reflector Clips
Box of 3



03520
Headlamp
Complete
(Includes Dip
Switch and Dip
Switch Lead)

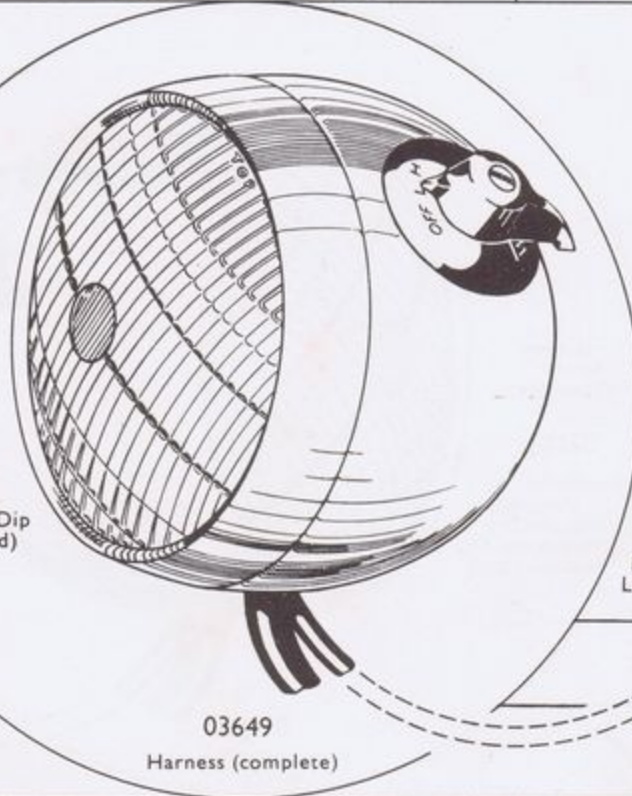

03649
Harness (complete)



03561 Rim



06195
Dip Switch

03629
Dip switch
Leads



03586
Rim Locking
Screw



02496
Headlamp Fixing
Bolts & Washers



Terminal
Screw Set
06820
(Set of 4)

Switch Body Unit 06816



Knob set
06818

Screw and
Washer Set
06817











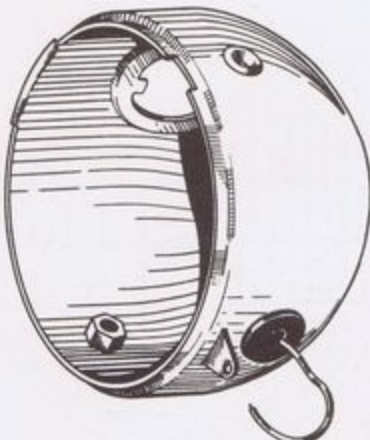

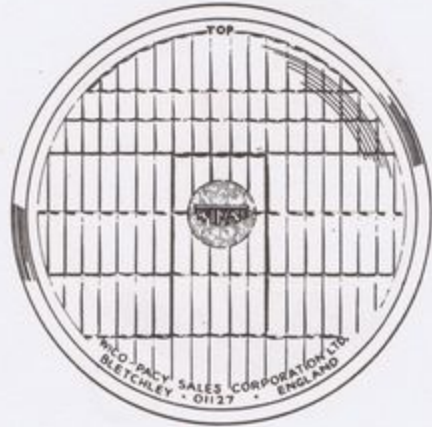

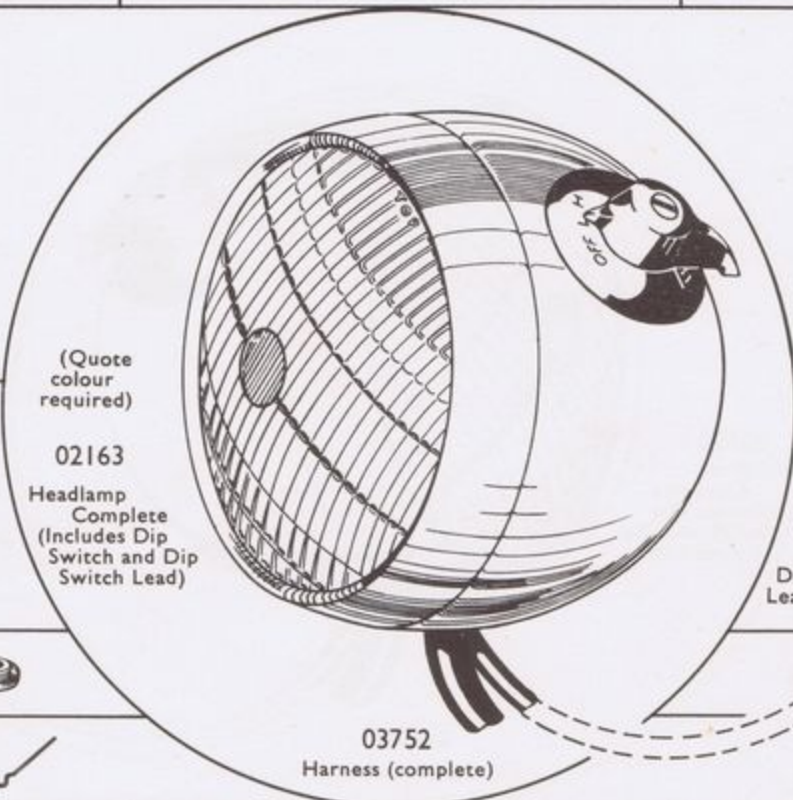



Cover and Gasket Set 06819





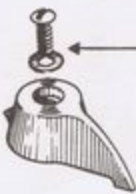





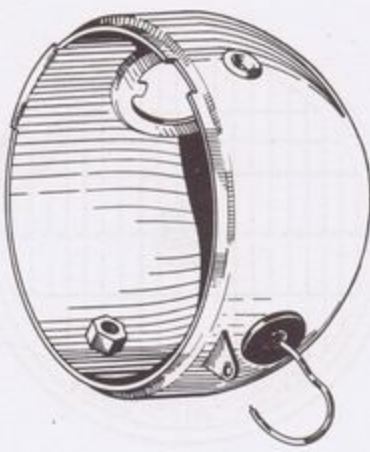

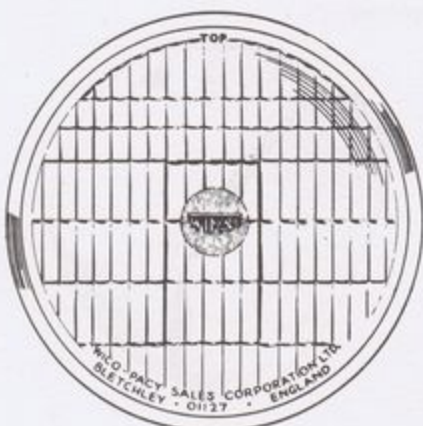

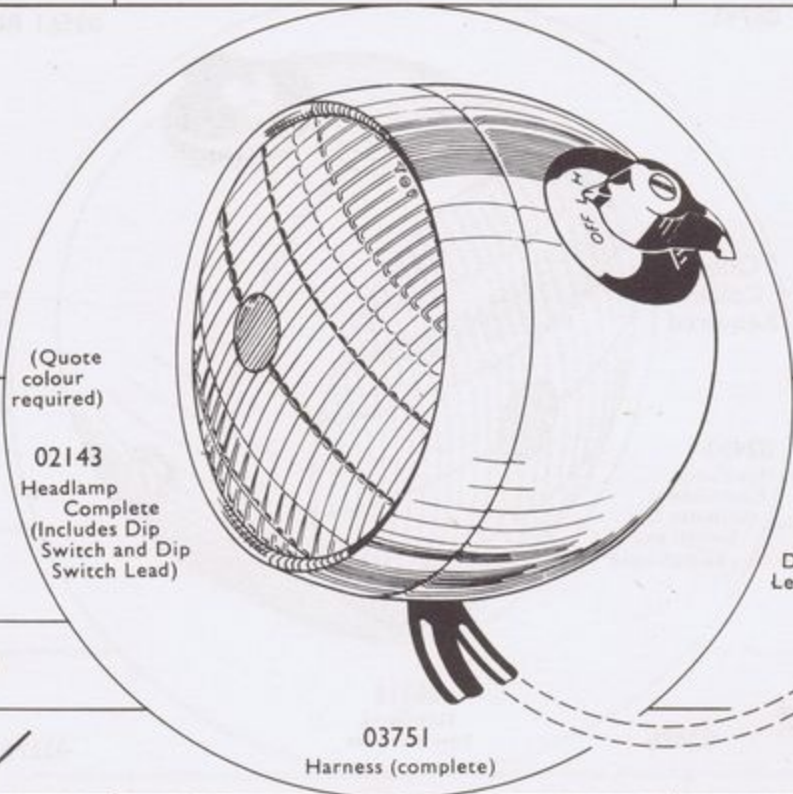













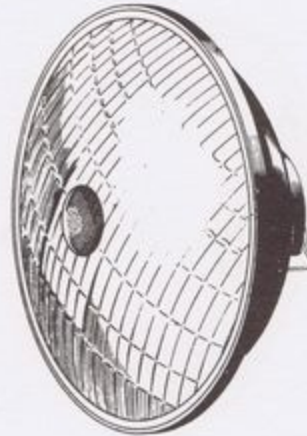
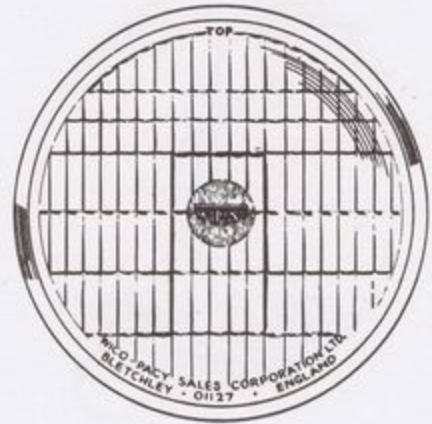

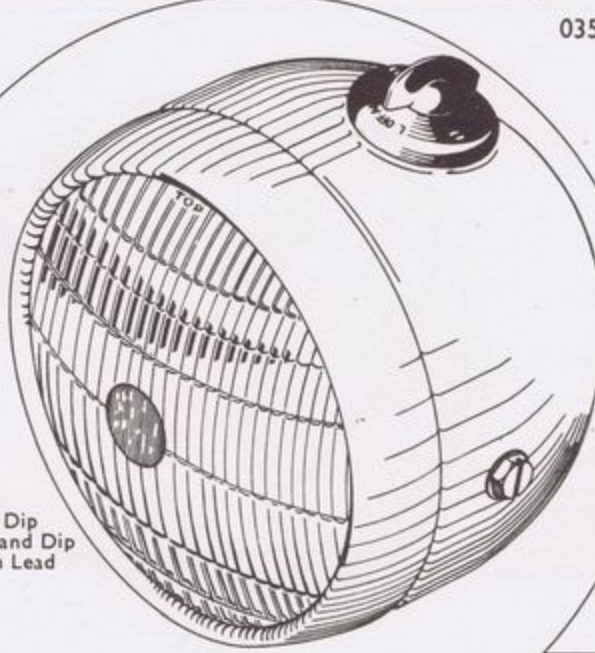



Switch Unit 03625













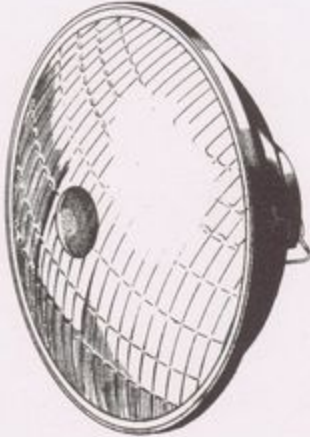

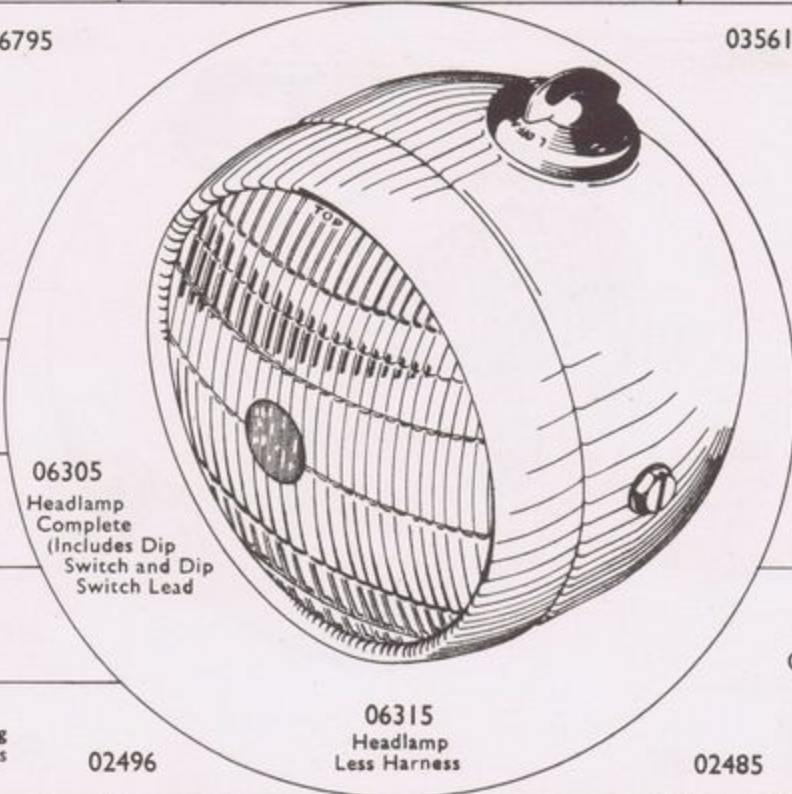

<p>02160</p>  <p>Lamp Body Unit (Quote colour required)</p>	<p>S0505</p>  <p>Reflector and Glass Set</p>	<p>01127</p>  <p>Headlamp Glass</p>	
<p>06795</p>  <p>Bulb Holder Unit</p>	 <p>(Quote colour required)</p> <p>02163 Headlamp Complete (Includes Dip Switch and Dip Switch Lead)</p> <p>03752 Harness (complete)</p>		 <p>03561 Rim</p>
<p>03678</p>  <p>Battery Retaining Clip</p>			<p>02138</p>  <p>Dip switch Leads</p> <p>06195</p>  <p>Dip Switch</p>
<p>04938</p>  <p>Pilot Bulb Holder</p>			<p>03586</p>  <p>Rim Locking Screw</p>
<p>06525</p>  <p>Reflector Clips Box of 3</p>			<p>02496</p>  <p>Headlamp Fixing Bolts & Washers</p>
<div data-bbox="57 1725 618 2339"> <p>Terminal Screw Set 06820 (Set of 4)</p>  <p>Switch Body Unit 06816</p> </div> <div data-bbox="618 1725 1173 2022"> <p>Screw and Washer Set 06817</p>  <p>Knob set 06818</p> </div> <div data-bbox="618 2022 1173 2339">  <p>Cover and Gasket Set 06819</p> </div> <div data-bbox="1173 1725 1741 2339">  <p>Switch Unit 03625</p> </div>			





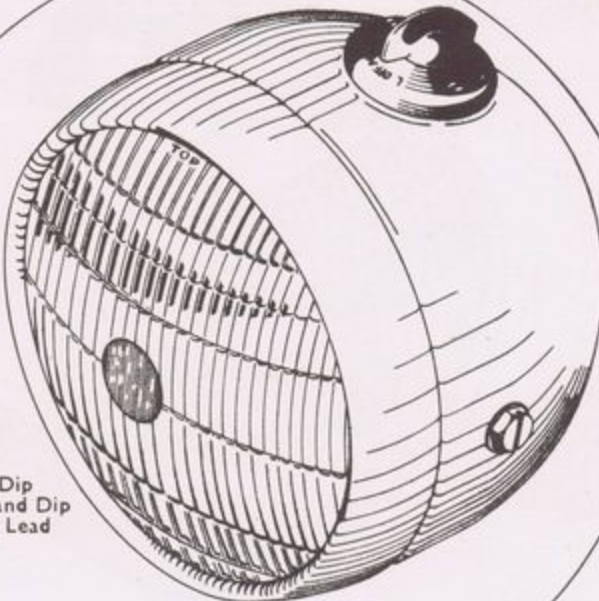



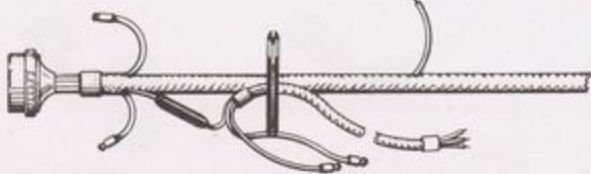
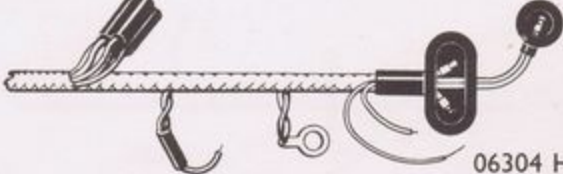



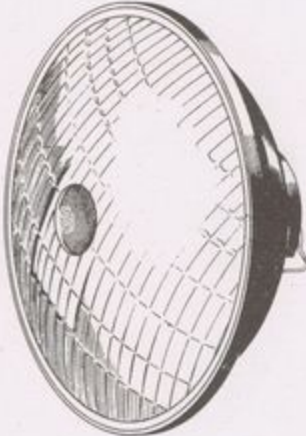
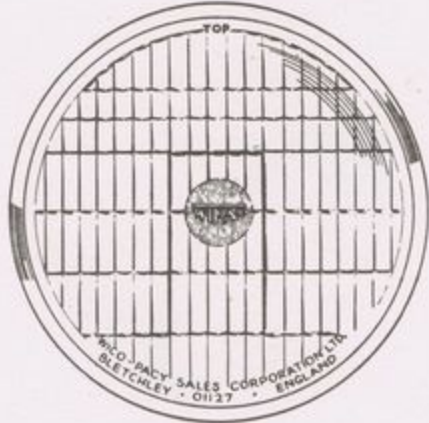

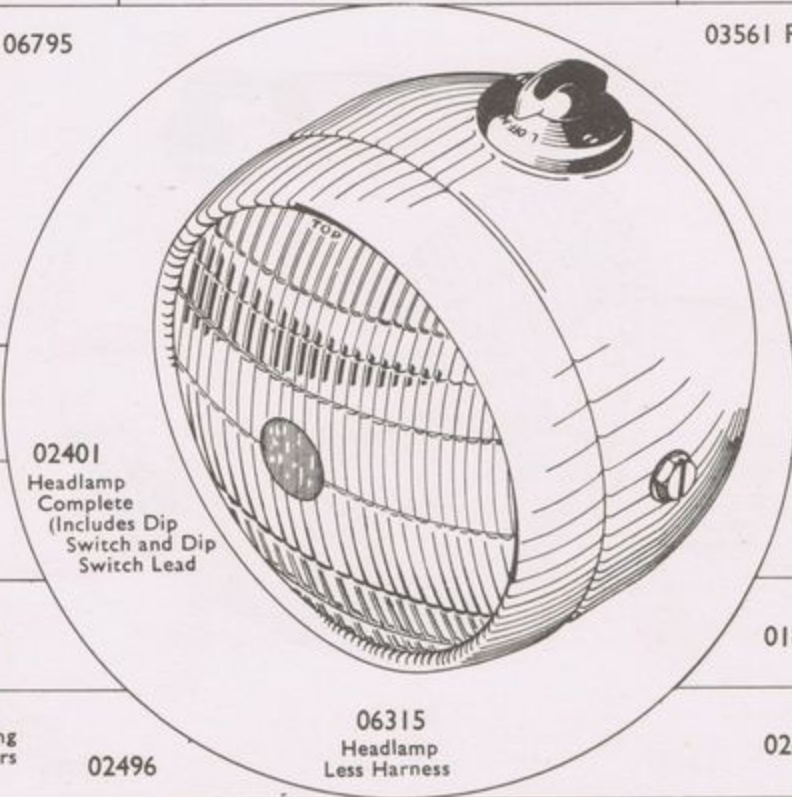



<p>02139</p>  <p>Lamp Body Unit (Quote colour required)</p>	<p>S0505</p>  <p>Reflector and Glass Set</p>	<p>01127</p>  <p>Headlamp Glass</p>	
<p>06795</p>  <p>Bulb Holder Unit</p>	 <p>(Quote colour required)</p> <p>02143 Headlamp Complete (Includes Dip Switch and Dip Switch Lead)</p> <p>03751 Harness (complete)</p>		 <p>03561 Rim</p>
<p>02496</p>  <p>Headlamp Fixing Bolts & Washers</p>			<p>02138</p>  <p>Dip switch Leads</p>
<p>04938</p>  <p>Pilot Bulb Holder</p>			<p>06195</p>  <p>Dip Switch</p>
<p>06525</p>  <p>Reflector Clips Box of 3</p>			<p>03586</p>  <p>Rim Locking Screw</p>
<p>Terminal Screw Set 06820 (Set of 4)</p>  <p>Switch Body Unit 06816</p>	<p>Screw and Washer Set 06817</p>  <p>Knob set 06818</p>	 <p>Switch Unit 03625</p>	
 <p>Cover and Gasket Set 06819</p>			

<p>Quote Colour Required</p> <p>05757</p>  <p>Lamp Body Unit</p>	<p>S0505</p>  <p>Reflector and Glass Set</p>	<p>01127</p>  <p>Headlamp Glass</p>
<p>06795</p>  <p>Bulb Holder Unit (includes 4 connector plugs)</p>	<p>Quote Colour Required</p>  <p>02402 Headlamp Complete (Includes Dip Switch and Dip Switch Lead)</p> <p>02496</p> <p>06316 Headlamp Less Harness</p>	<p>03561 Rim</p> 
<p>04938 Pilot Bulb Holder</p> 		<p>06195 Dip Switch</p> 
<p>06525 Reflector Clips Box of 3</p> 		<p>00608 Connector (Single)</p> 
<p>03586 Rim Locking Screw</p> 		<p>Connector (5 Way) 01875</p> 
<p>Headlamp Fixing Bolts & Washers</p> 		<p>03678 Battery Retaining Clip</p> 
<p>06587</p>  <p>Switch Body Unit</p>	<p>06588</p>  <p>Switch Cover and Knob Group</p>	<p>06291</p>  <p>Switch Complete</p>
<p>S0526 (Blue) Plug Unit</p>  <p>05760 Harness Complete 05749 Dip Switch Leads</p>		



<p>05747</p>  <p>Lamp Body Unit</p>	<p>S0505</p>  <p>Reflector and Glass Set</p>	<p>01127</p>  <p>Headlamp Glass</p>
<p>06795</p>  <p>Bulb Holder Unit (includes 4 connector plugs)</p>	 <p>06305 Headlamp Complete (Includes Dip Switch and Dip Switch Lead)</p>	<p>03561 Rim</p> 
<p>04938</p>  <p>Pilot Bulb Holder</p>		<p>06195</p>  <p>Dip Switch</p>
<p>06525</p>  <p>Reflector Clips Box of 3</p>		<p>00608</p>  <p>Connector (Single)</p>
<p>03586</p>  <p>Rim Locking Screw</p>		<p>Connector (4 Way)</p> 
<p>Headlamp Fixing Bolts & Washers</p> 		<p>02496</p> <p>06315</p>  <p>Headlamp Less Harness</p>
<p>06587</p>  <p>Switch Body Unit</p>	<p>06588</p>  <p>Switch Cover and Knob Group</p>	<p>06291</p>  <p>Switch Complete</p>
<p>S0526 (Blue) Plug Unit</p>  <p>06304 Harness Complete 05749 Dip Switch Leads</p> 		

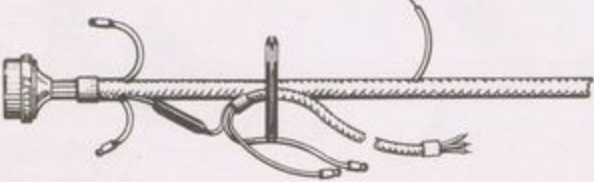

<p>05747</p>  <p>Lamp Body Unit</p>	<p>S0505</p>  <p>Reflector and Glass Set</p>	<p>01127</p>  <p>Headlamp Glass</p>
<p>06795</p>  <p>Bulb Holder Unit (includes 4 connector plugs)</p>	 <p>02401 Headlamp Complete (Includes Dip Switch and Dip Switch Lead)</p>	<p>03561 Rim</p> 
<p>04938 Pilot Bulb Holder</p> 		<p>06195 Dip Switch</p> 
<p>06525 Reflector Clips Box of 3</p> 		<p>00608 Connector (Single)</p> 
<p>03586 Rim Locking Screw</p> 		<p>01874 Connector (2 Way)</p> 
<p>Headlamp Fixing Bolts & Washers</p> 		<p>02485 Connector (4 Way)</p> 
<p>06587</p>  <p>Switch Body Unit</p>	<p>06588</p>  <p>Switch Cover and Knob Group</p>	<p>06291</p>  <p>Switch Complete</p>
<p>S0526 (Blue) Plug Unit</p>  <p>05752 Harness Complete 05749 Dip Switch Leads</p> 		





S0067 Switch Unit



S0069 Cover & Knob Group

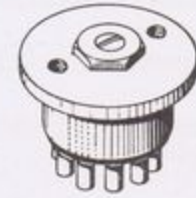

S0068 Switch Body Unit

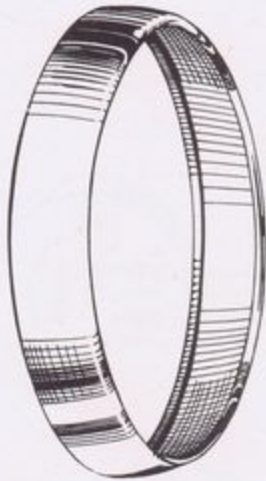

S0066 Rim

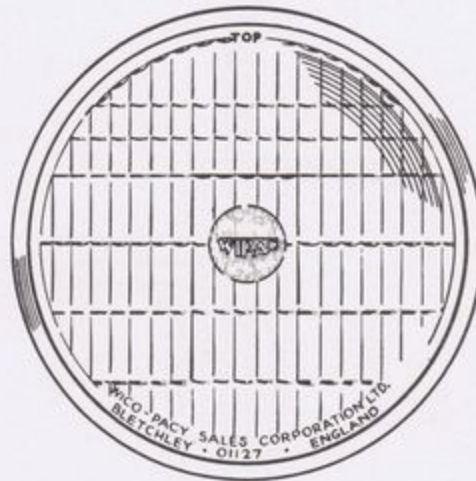

01127 Headlamp Glass

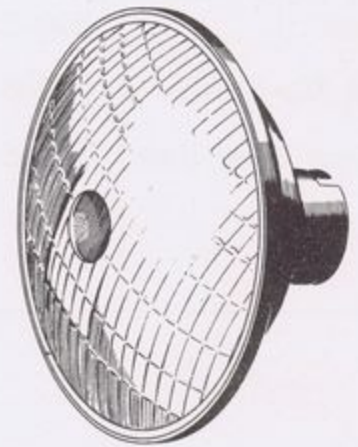

S0507 Reflector and Glass Set



06205 Horn & Dip Switch



S0070 Reflector Clips (set of 4)



04938 Pilot Bulb Holder



S0064 Rim Locking Set



S0072 Horn & Dip Switch Harness



00915 Main Bulb Holder Unit

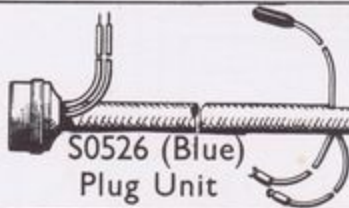

S0526 (Blue)
Plug Unit

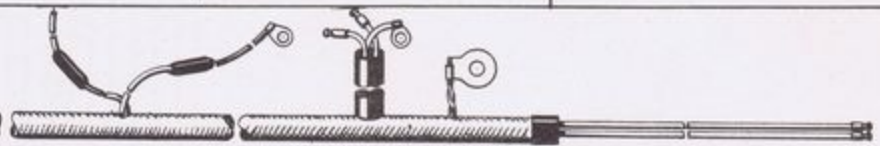

S0071 Main Harness



06166 Cover Unit

Cover Fixing
Set 06250

00608
Single
Connector



S0046 Twin Bulb
Rear Lamp (quote
bulbs required)



WIRING
WIPAC
 DIAGRAM









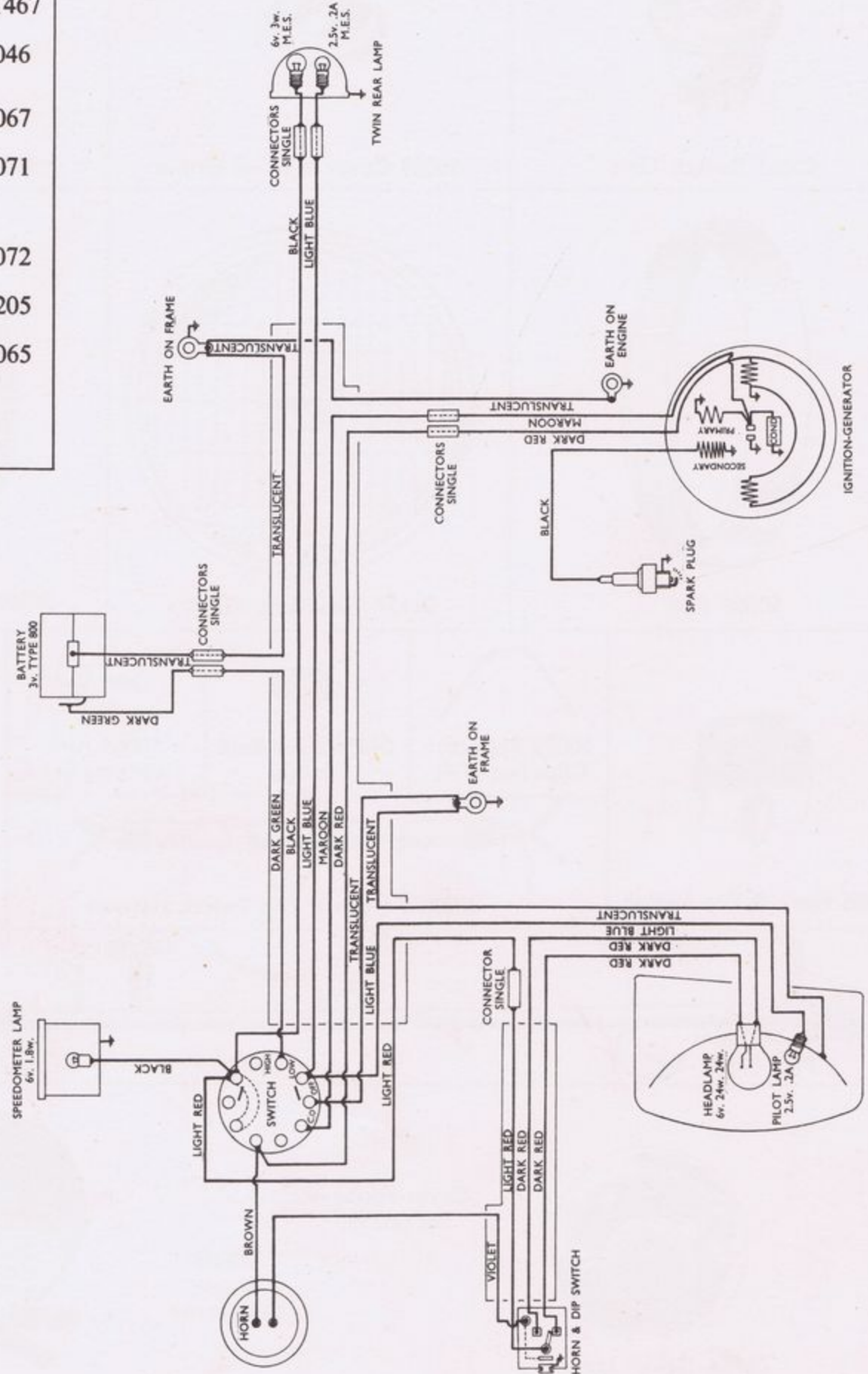

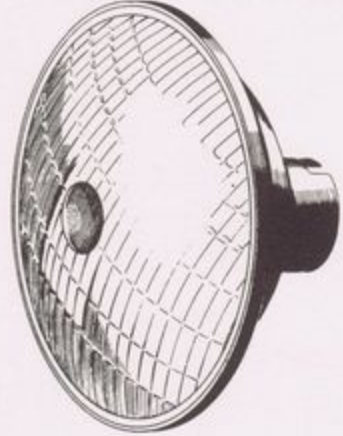
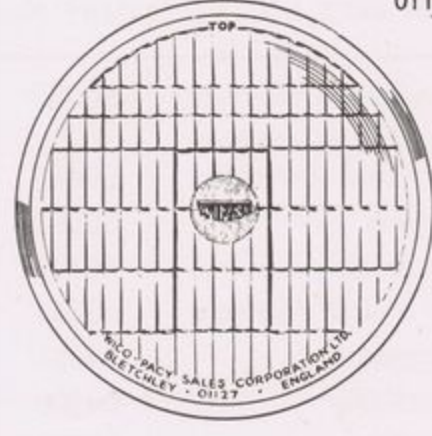



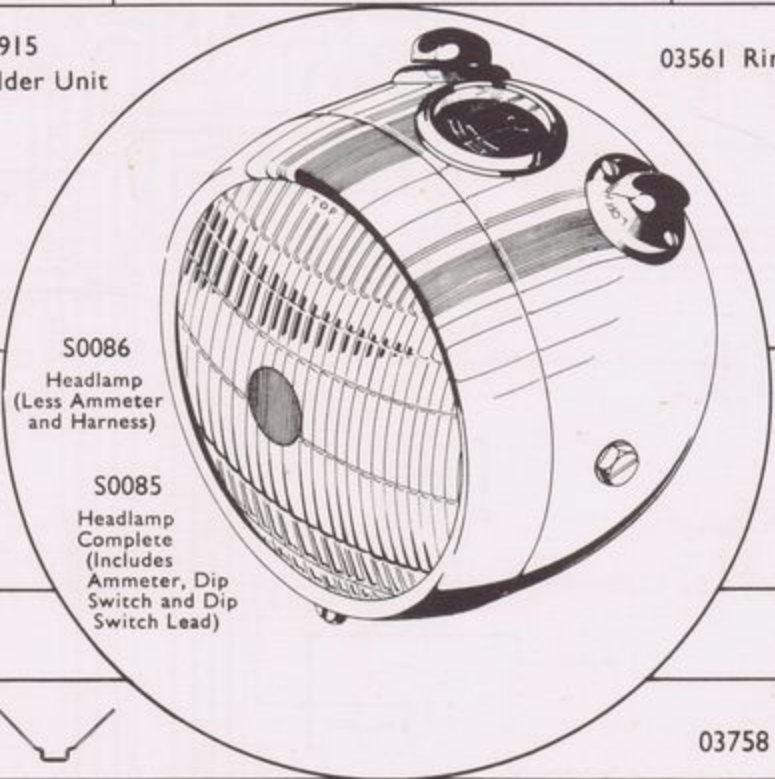



PIATTI Scooter (A.C. Lighting)

MODELS PRODUCED FROM MAY 1956

THE WIPAC GROUP · BLETCHLEY · ENGLAND

UNITS FOR SPARES	PART No.
Ignition—Generator	IG1467
Twin Rear Lamp (Quote bulbs required)	S0046
Switch Unit	S0067
Main Harness (S0072 not included)	S0071
Horn & Dip Switch Harness	S0072
Horn & Dip Switch	O6205
Headlamp Front Unit	S0065

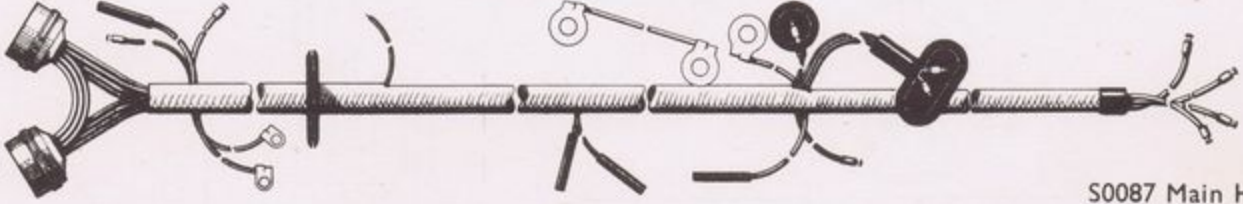

<p>S0094</p>  <p>Lamp Body Unit</p>	<p>S0506</p>  <p>Reflector and Glass Set</p>	<p>01127</p>  <p>Headlamp Glass</p>	
<p>02485</p>  <p>Connector (4 Way)</p>	<p>00608</p>  <p>Connector (Single)</p>	<p>01874</p>  <p>Connector (Double)</p>	
<p>00915</p>  <p>Bulb Holder Unit</p>			<p>03561 Rim</p> 
<p>S0062</p>  <p>Ammeter Unit</p>	<p>S0086</p> <p>Headlamp (Less Ammeter and Harness)</p> <p>S0085</p> <p>Headlamp Complete (Includes Ammeter, Dip Switch and Dip Switch Lead)</p>		<p>06195</p>  <p>Dip Switch</p>
<p>04938</p>  <p>Pilot Bulb Holder</p>	<p>03586</p>  <p>Rim Locking Screw</p>		<p>03758</p>  <p>Headlamp Fixing Bolts & Washers</p>
<p>S0C70</p>  <p>Reflector Clips Box of 4</p>	<p>06587</p>  <p>Switch Body Unit (Used on Both)</p>		<p>06589</p>  <p>Switch Cover and Knob Group (Ignition)</p>
<p>06588</p>  <p>Switch Cover and Knob Group (Lights)</p>	<p>Switch Complete</p> <p>06291 Lighting</p> <p>06292 Ignition</p> 		<p>05749</p>  <p>Dip Switch Harness</p>
<p>S0526 (Blue) Plug Unit</p>  <p>S0525 (Black) Plug Unit</p> 	 <p>S0087 Main Harness</p>		



WIRING WIPAC DIAGRAM









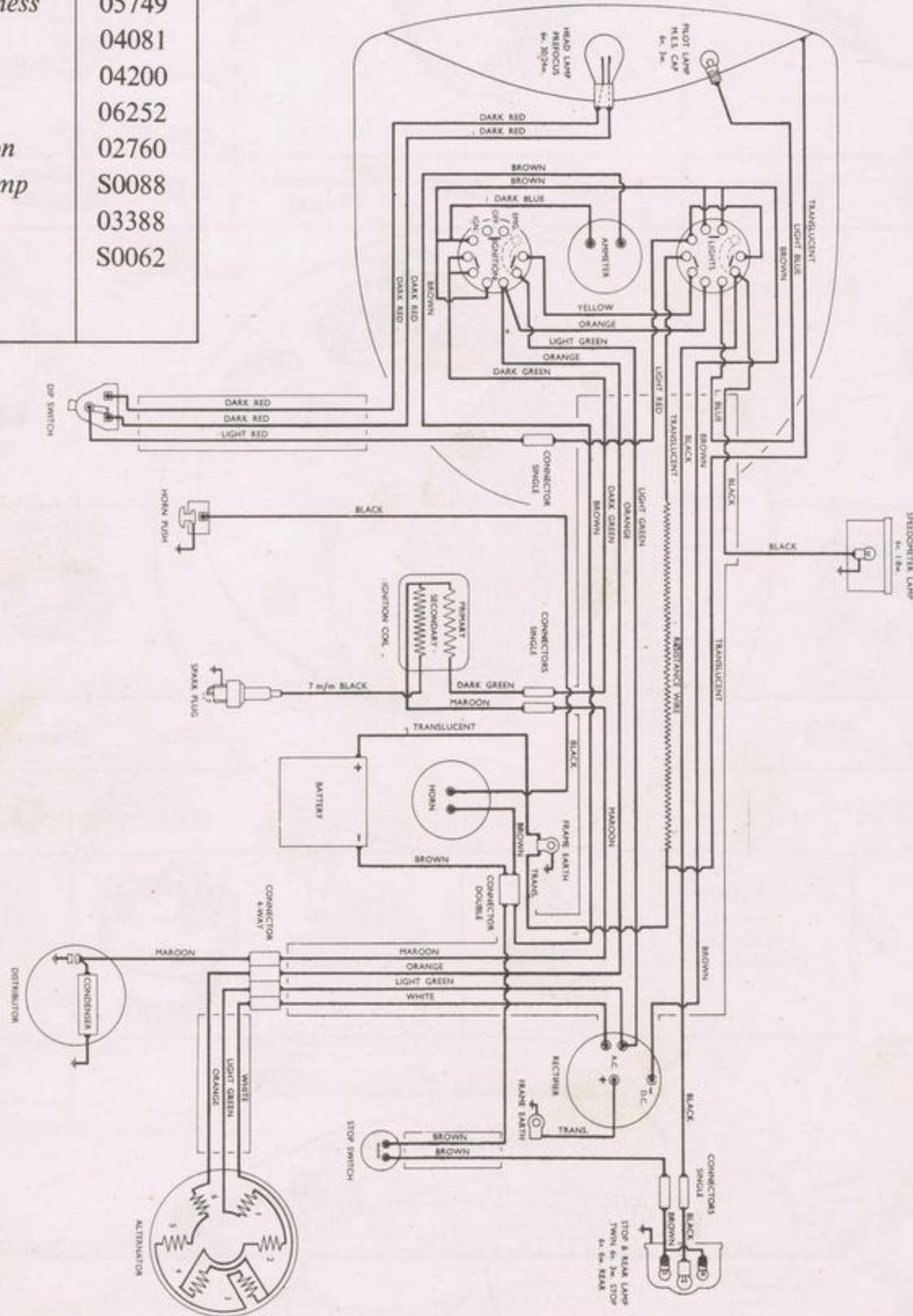

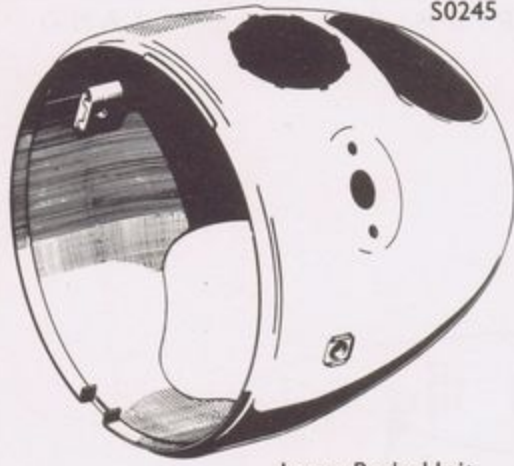





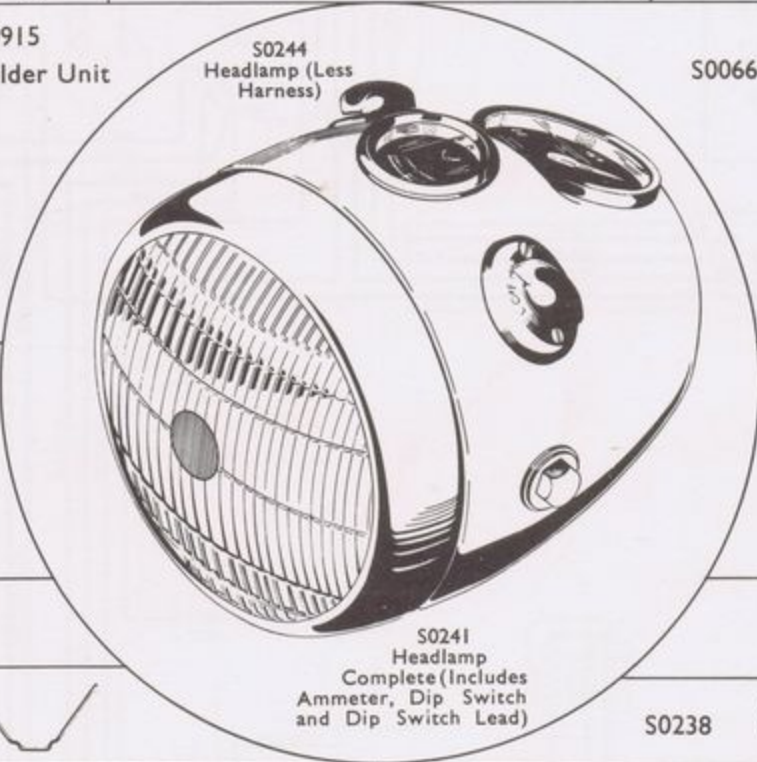



ARIEL model "Colt" L.H.

MODELS PRODUCED FROM AUGUST 1956

THE WIPAC GROUP · BLETCHLEY · ENGLAND

SPARES UNITS	PART No.
Headlamp (complete)	S0085
Headlamp (less harness and Ammeter)	S0086
Harness	S0087
Dip Switch	06195
Dip Switch Harness	05749
Alternator	04081
Distributor	04200
Rectifier	06252
Coil—6v. Ignition	02760
Stop & Rear Lamp	S0088
Stop Switch	03388
Ammeter Unit	S0062

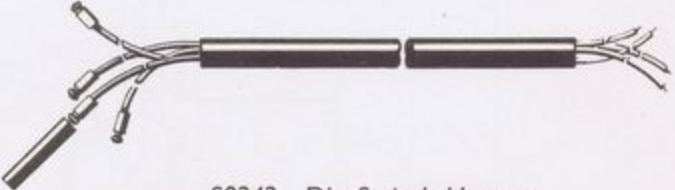

 <p>S0245 Lamp Body Unit</p>	 <p>S0507 Reflector and Glass Set</p>	 <p>01127 Headlamp Glass</p>	
<p>02485  Connector (4 Way)</p>	<p>00608  Connector (Single)</p>	<p>01874  Connector (Double)</p>	
<p>00915 Bulb Holder Unit</p> 	 <p>S0244 Headlamp (Less Harness)</p> <p>S0241 Headlamp Complete (Includes Ammeter, Dip Switch and Dip Switch Lead)</p>	<p>S0066 Rim</p> 	
<p>S0062 Ammeter Unit</p> 		<p>06205 Horn and Dip switch</p> 	
<p>04938 Pilot Bulb Holder</p> 		<p>S0064 Rim Locking Set</p> 	
<p>S0070 Reflector Clips Box of 4</p> 		<p>S0238 Headlamp Fixing Set</p> 	
<p>06588 Switch Cover and Knob Group (Lights)</p> 		<p>06587 Switch Body Unit (Used on Both)</p> 	<p>Switch Complete 06291 Lighting 06292 Ignition</p> 
<p>S0526 (Blue) Plug Unit</p> 	<p>S0525 (Black) Plug Unit</p> 	<p>S0243 Main Harness</p> 	<p>S0242 Dip Switch Harness</p> 











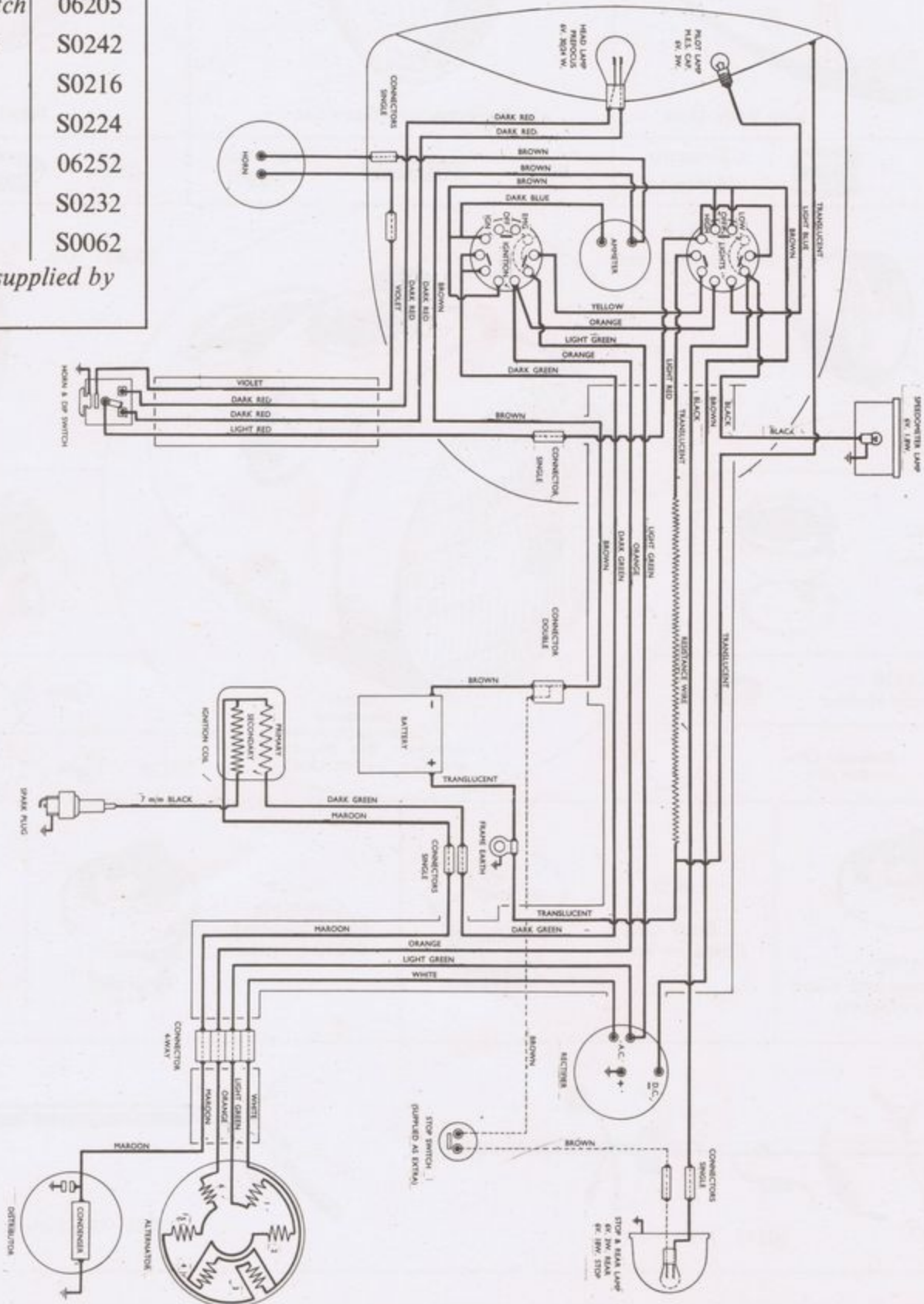

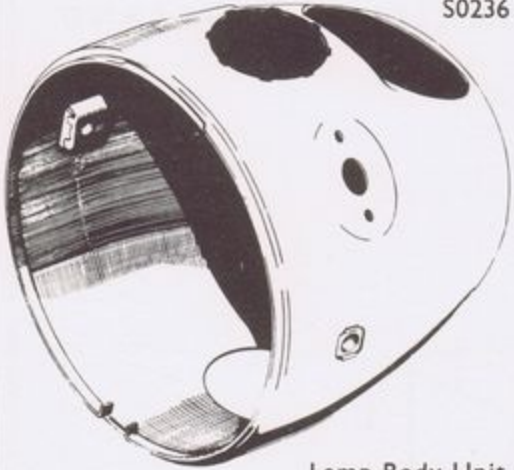
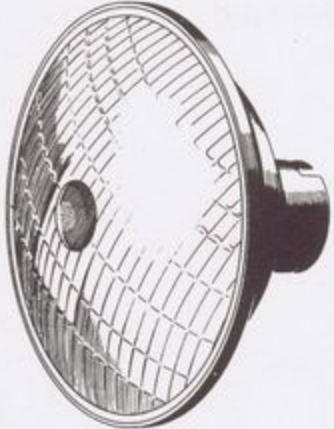
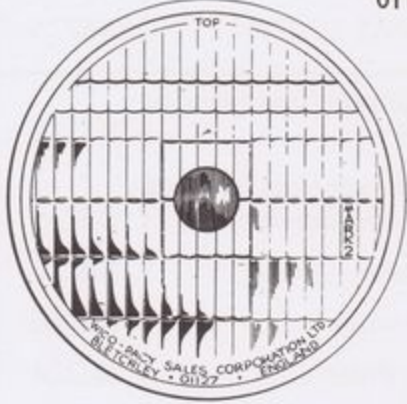

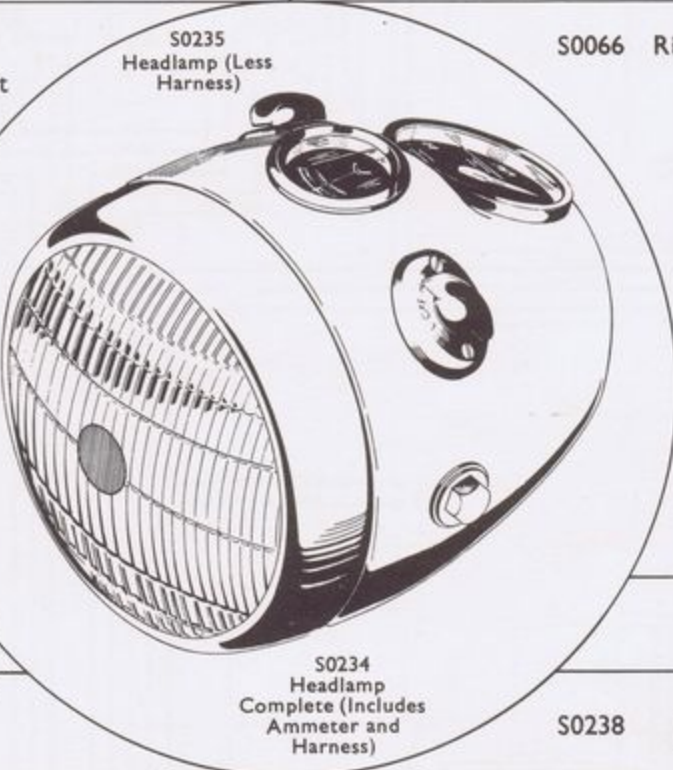

WIRING WIPAC DIAGRAM

FRANCIS-BARNETT 250 c.c. CRUISER 80 MODELS PRODUCED FROM AUGUST 1956



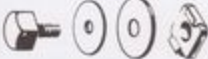



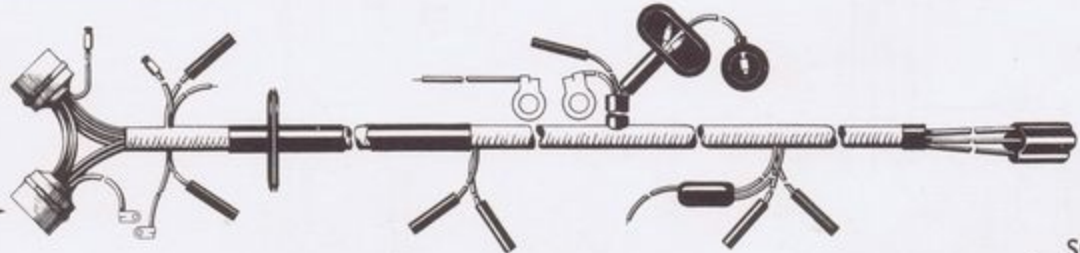



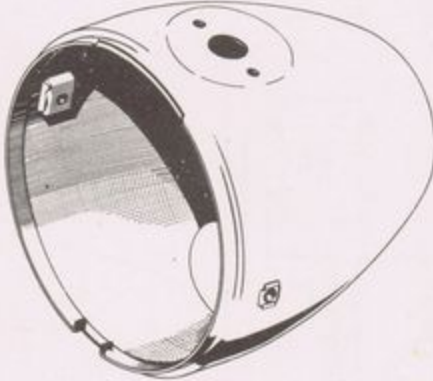

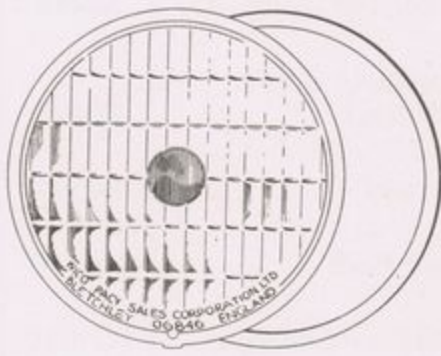

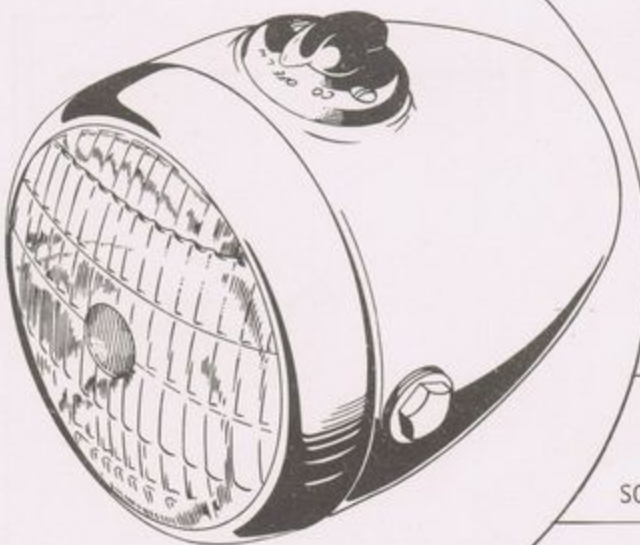
THE WIPAC GROUP · BLETCHLEY · ENGLAND

SPARES UNITS	PART No.
*Headlamp (less speedometer)	S0241
*Headlamp (less harness and speedometer)	S0244
Harness	S0243
Horn and Dip Switch	06205
Dip Switch Harness	S0242
Alternator	S0216
Base Plate Unit	S0224
Rectifier	06252
Coil—6v. Ignition	S0232
Ammeter Unit	S0062
*Speedometer not supplied by Wipac	

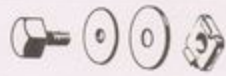

 <p>S0236 Lamp Body Unit</p>	 <p>S0507 Reflector and Glass Set</p>	 <p>01127 Headlamp Glass</p>	
<p>00608  Connector (Single)</p>	<p>01874  Connector (Double)</p>		
<p>00915  Bulb Holder Unit</p>	 <p>S0234 Headlamp Complete (Includes Ammeter and Harness)</p>	<p>S0066  Rim</p>	
<p>S0062  Ammeter Unit</p>		<p>02485  Connector (4 Way)</p>	
<p>04938  Pilot Bulb Holder</p>		<p>S0064  Rim Locking Set</p>	
<p>S0070  Reflector Clips (Box of 4)</p>		<p>S0238  Headlamp Fixing Bolts & Washers</p>	
<p>06588  Switch Cover and Knob Group (Lights)</p>		<p>06587  Switch Body Unit (Used on Both)</p>	<p>Switch Complete 06291 Lighting 06292 Ignition</p> 
 <p>S0239 Main Harness</p> <p>S0526 (Blue) Plug Unit</p> <p>S0525 (Black) Plug Unit</p>			

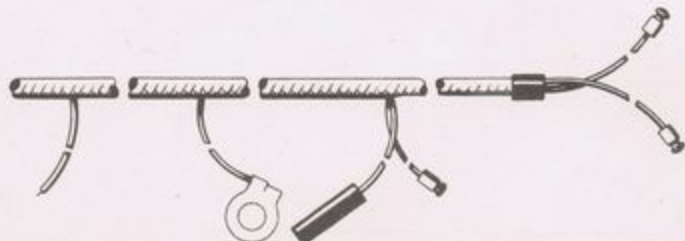

<p>S0500</p>  <p>Lamp Body Set</p>	<p>S0509</p>  <p>Reflector and Glass Set</p>	<p>S0348</p>  <p>Headlamp Glass Set</p>	
<p>S0503 Main Bulb Holder Set</p> 	<p>S0499 Headlamp (Less Harness)</p>  <p>Quote Colour On Order</p> <p>S0498 Headlamp Complete With Harness</p>		<p>S0349 Rim</p> 
<p>S0351 Pilot Bulb Holder Set</p> 			<p>S0350 Reflector Clips Set (Box of 3)</p> 
<p>00608 Connector (Single)</p> 			<p>S0064 Rim Locking Set</p> 
<p>S0238 Headlamp Fixing Set</p> 			<p>S0067 Switch Unit</p> 
<p>S0068 Switch Body Unit</p> 			
<p>S0526 (Blue) Plug Unit</p> 		<p>S0504 Main Harness</p>	



WIRING WIPAC DIAGRAM









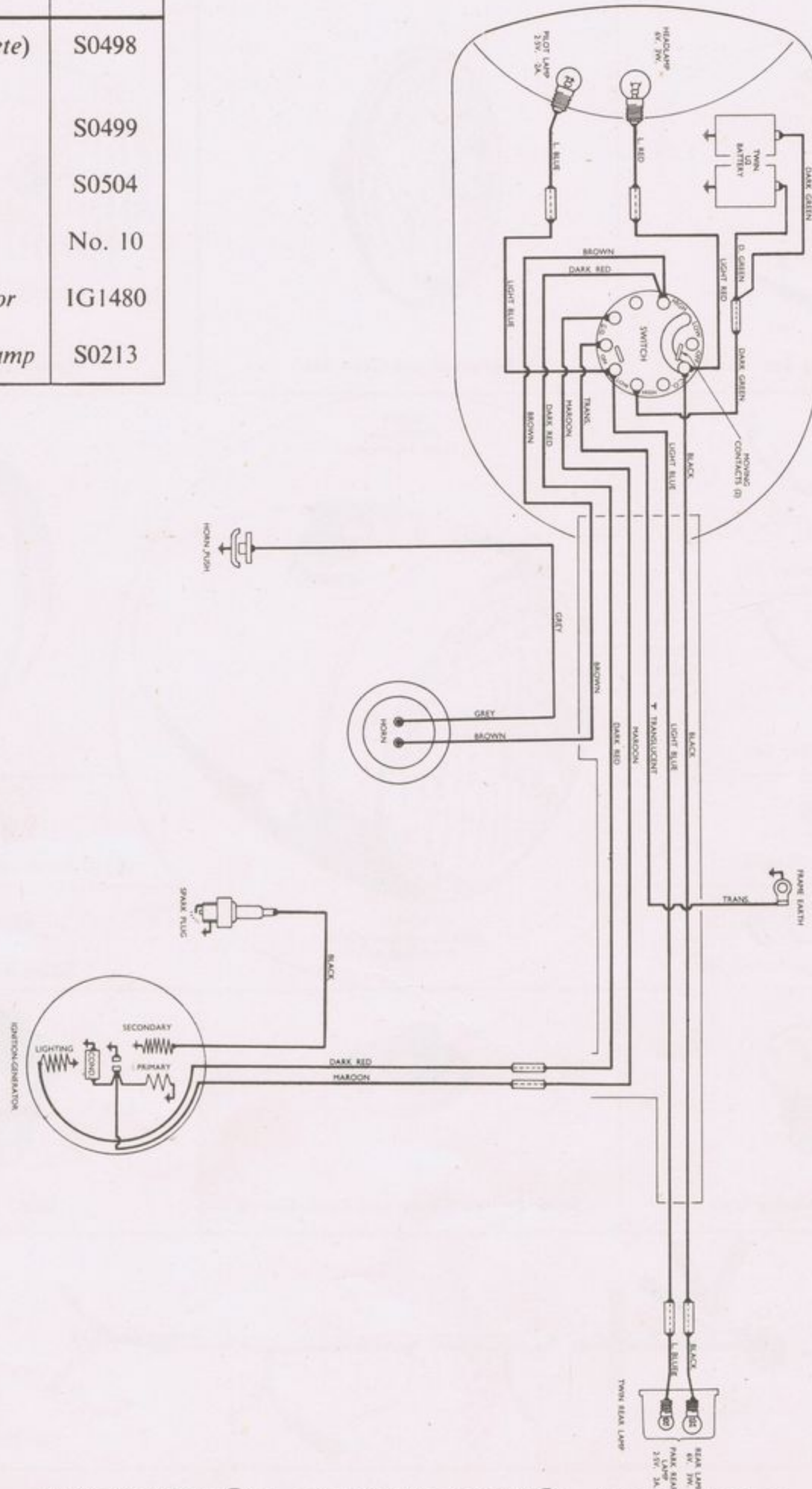

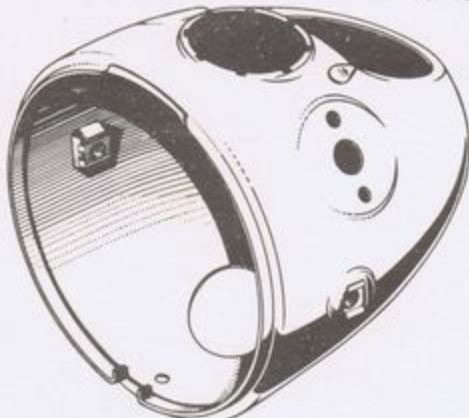

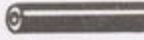

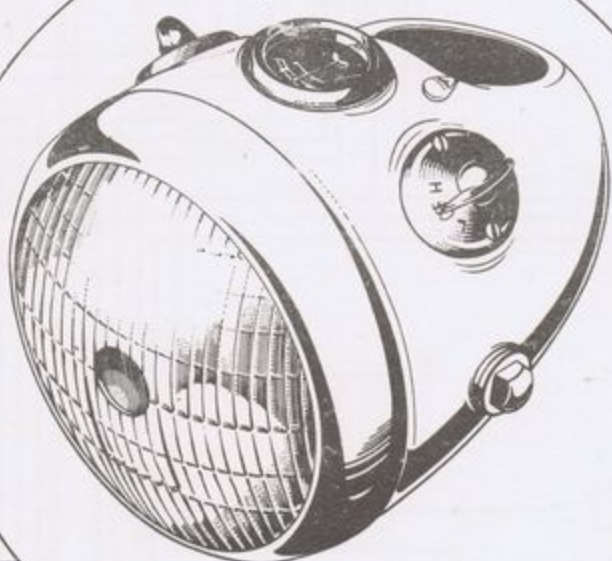
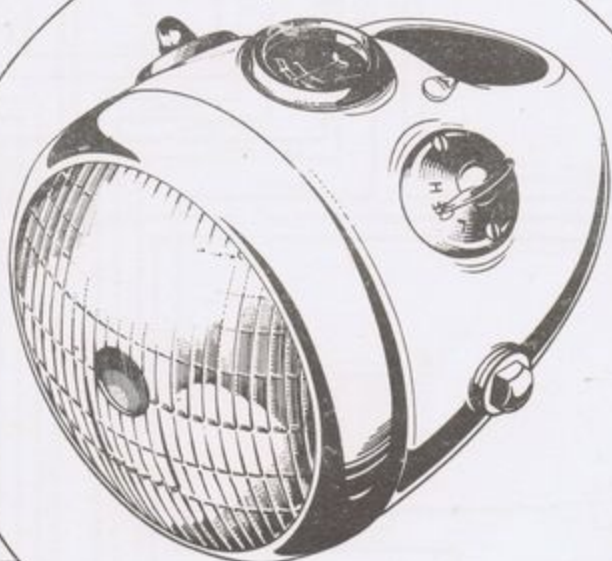

DUNKLEY WHIPPET 60 SCOOTERETTE

MODELS PRODUCED FROM MARCH 1957

THE WIPAC GROUP · BLETCHLEY · ENGLAND

UNITS FOR SPARES	PART No.
Headlamp (complete)	S0498
Headlamp (less harness)	S0499
Harness	S0504
Horn Push	No. 10
Ignition—Generator	IG1480
Parking & Rear Lamp	S0213

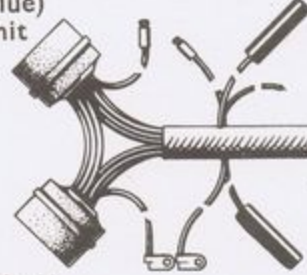
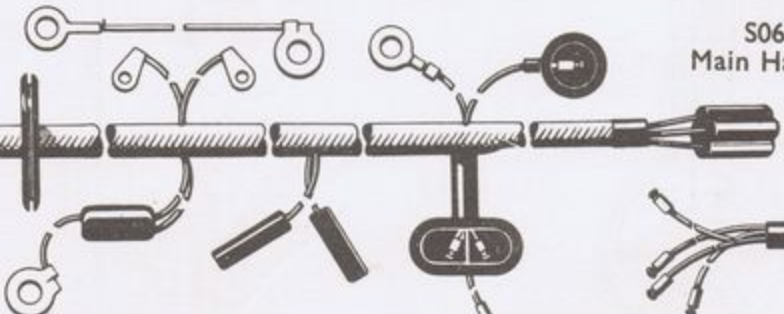
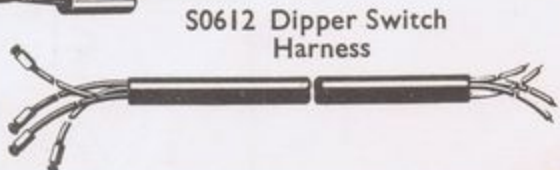

<p>S0507</p>  <p>Reflector and Glass Set</p>	<p>S0752</p>  <p>Lamp Body Unit</p>	<p>S0066</p>  <p>Rim</p>	
<p>02485</p>  <p>Connector (Four Way)</p>	<p>00608</p>  <p>Connector (Single)</p>	<p>01874</p>  <p>Connector (Double)</p>	
<p>00915</p>  <p>Bulb Holder Unit</p>	<p>S0751</p>  <p>Headlamp (Less Harness)</p> <p>S0610</p>  <p>Headlamp Complete (Includes Ammeter and Harness)</p>	<p>S0062</p>  <p>Ammeter Unit</p>	
<p>S0613</p>  <p>Horn and Dipper Switch</p>		<p>S0064</p>  <p>Rim Locking Set</p>	<p>Headlamp Fixing Bolts & Washers S0238</p> 
<p>Reflector Clips (Box of Four) S0070</p> 		<p>04938</p>  <p>Pilot Bulb Holder</p>	
<p>06588</p>  <p>Switch Cover & Knob Group (Lights)</p>		<p>06587</p>  <p>Switch Body Unit (Used on Both)</p>	<p>Switch Complete 06291 (Lighting) 06292 (Ignition)</p> 
		<p>06589</p>  <p>Switch Cover & Knob Group (Ignition)</p>	
<p>S0526 (Blue) Plug Unit</p> 	<p>S0611</p>  <p>Main Harness</p>		<p>S0612</p>  <p>Dipper Switch Harness</p>
<p>S0525 (Black) Plug Unit</p> 			











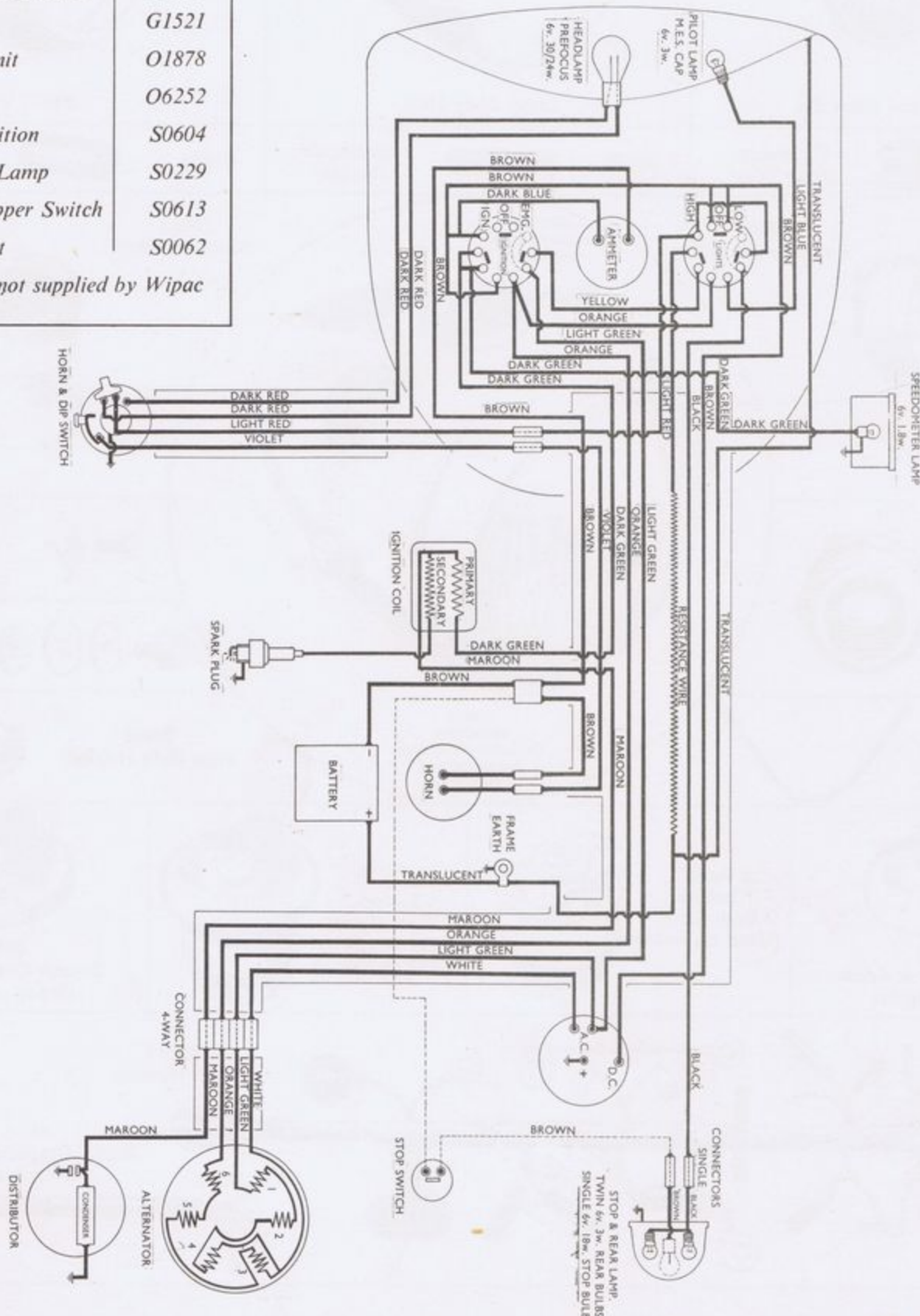



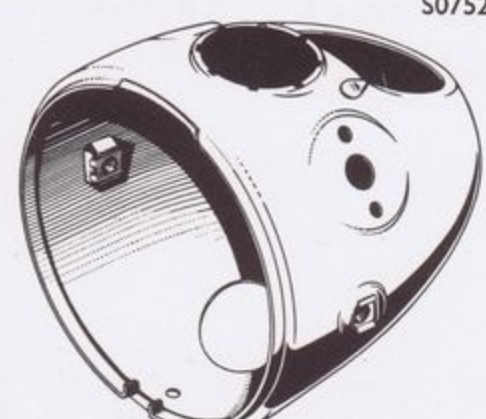





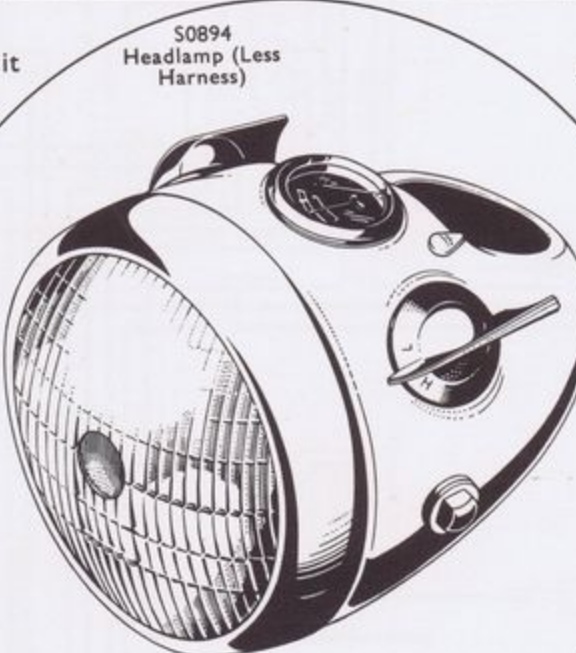
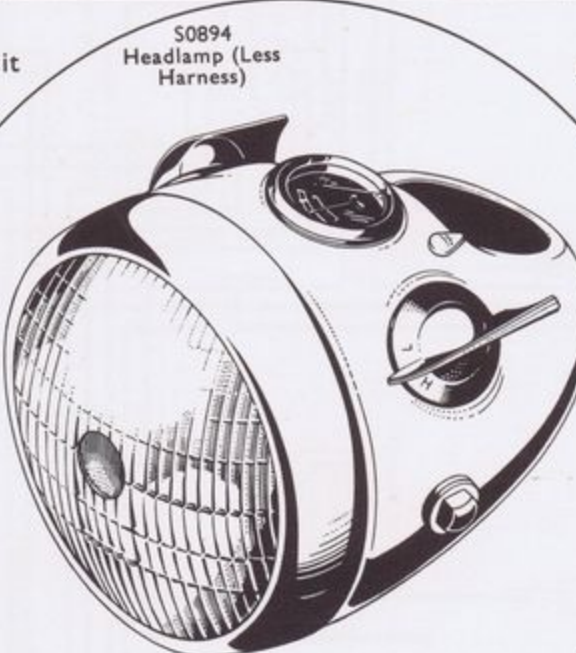

WIRING WIPAC DIAGRAM

MATCHLESS G2 and A.J.S. MODEL 14 250 c.c. O.H.V. MOTOR CYCLES MODELS PRODUCED FROM JUNE 1958 TO SEPTEMBER 1958

THE WIPAC GROUP · BLETCHLEY · ENGLAND

SPARES UNITS	PART No.
* Headlamp (less speedometer)	S0610
* Headlamp (less harness and speedometer)	S0751
Harness	S0611
Dipper Switch Harness	S0612
Alternator	G1521
Base Plate Unit	O1878
Rectifier	O6252
Coil—6v. Ignition	S0604
Stop & Rear Lamp	S0229
Horn and Dipper Switch	S0613
Ammeter Unit	S0062
* Speedometer not supplied by Wipac	

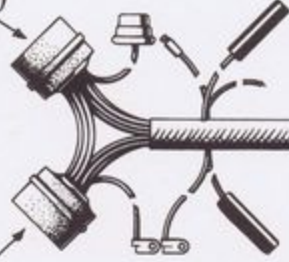

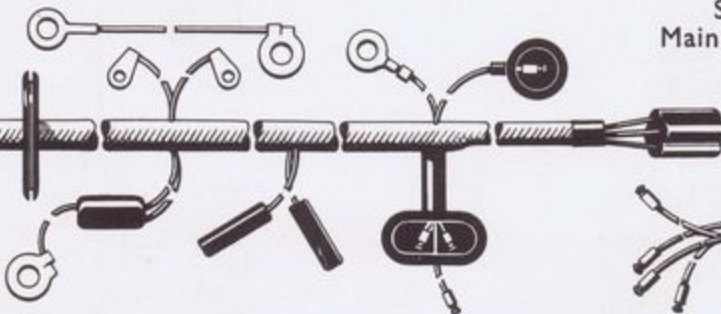
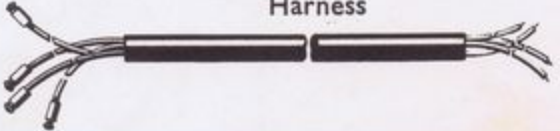
<p>S0507</p>  <p>Reflector and Glass Set</p>	<p>S0752</p>  <p>Lamp Body Unit</p>	<p>S0066</p>  <p>Rim</p>	
<p>02485</p>  <p>Connector (Four Way)</p>	<p>00608</p>  <p>Connector (Single)</p>	<p>01874</p>  <p>Connector (Double)</p>	
<p>S0768</p>  <p>Bulb Holder Unit</p>	<p>S0894</p>  <p>Headlamp (Less Harness)</p> <p>S0850</p>  <p>Headlamp Complete (Includes Ammeter and Harness)</p>	<p>S0062</p>  <p>Ammeter Unit</p>	
<p>S0613</p>  <p>Horn and Dipper Switch</p>		<p>S0064</p>  <p>Rim Locking Set</p> <p>Headlamp Fixing Bolts & Washers S0238</p> 	
<p>Reflector Clips (Box of Four) S0070</p> 		<p>S0895</p>  <p>Pilot Bulb Holder</p>	
<p>S0783</p>  <p>Switch Knob Group (Lights)</p>		<p>Switch Complete S0781 (Lights) S0782 (Ignition)</p> 	<p>S0784</p>  <p>Switch Knob Group (Ignition)</p>
<p>S0526 (Blue) Plug Unit</p>  <p>S0525 (Black) Plug Unit</p>  <p>S0611</p>  <p>Main Harness</p> <p>S0612</p>  <p>Dipper Switch Harness</p>			



WIRING WIPAC DIAGRAM

MATCHLESS G2 and A.J.S. MODEL 14 250 c.c. O.H.V. MOTOR CYCLES

MODELS PRODUCED FROM OCTOBER 1958

THE WIPAC GROUP · BLETCHLEY · ENGLAND

SPARES UNITS	PART No.
*Headlamp (less speedometer)	S0850
*Headlamp (less harness and speedometer)	S0894
Harness	S0611
Dipper Switch Harness	S0612
Alternator	G1521
Base Plate Unit	O1878
Rectifier	O6252
Coil—6v. Ignition	S0604
Stop & Rear Lamp	S0229
Horn and Dipper Switch	S0613
Ammeter Unit	S0062
*Speedometer not supplied by Wipac	

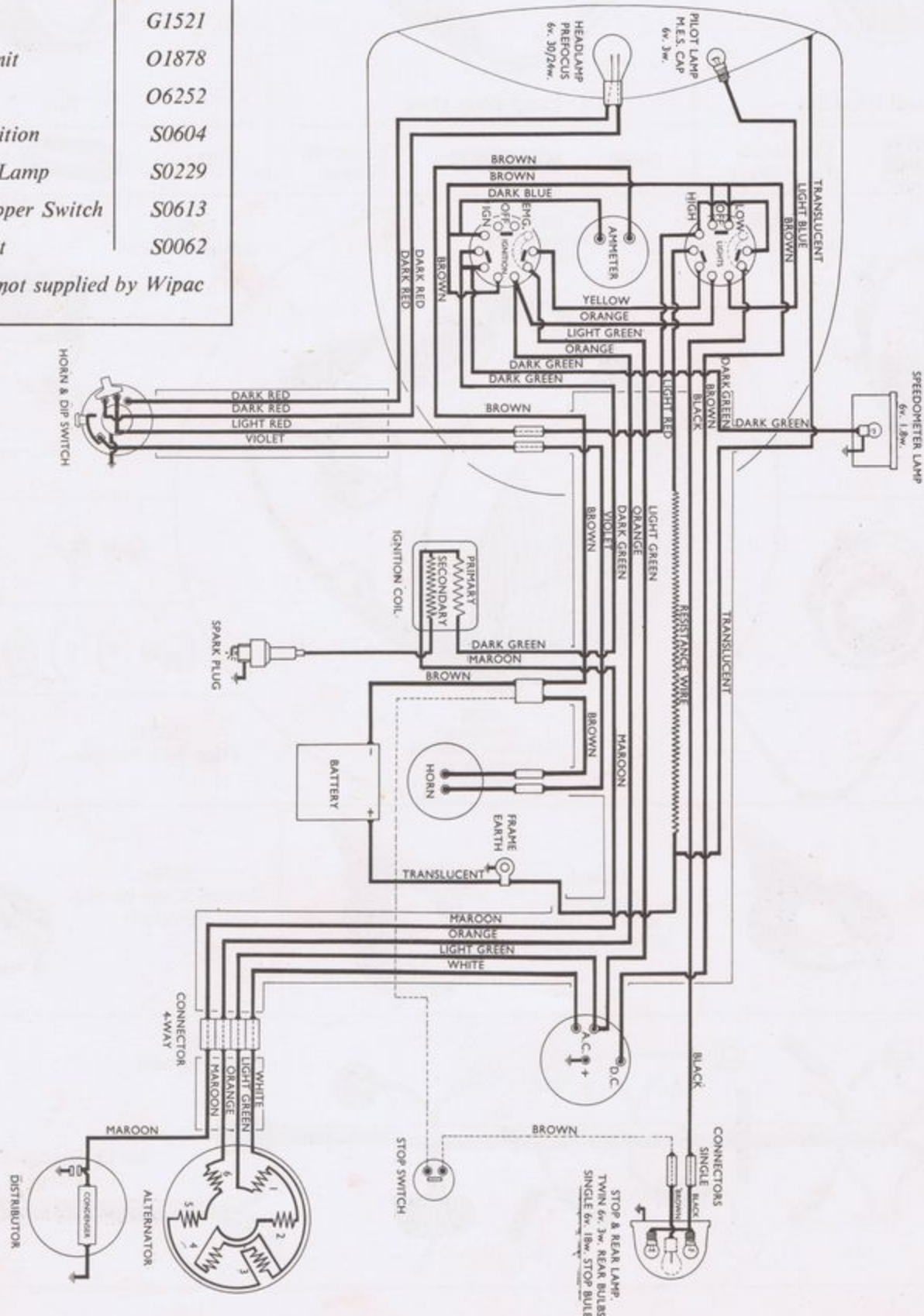

WIRING **WIPAC** DIAGRAM

B.S.A. C.10.L. MOTOR CYCLE EQUIPMENT

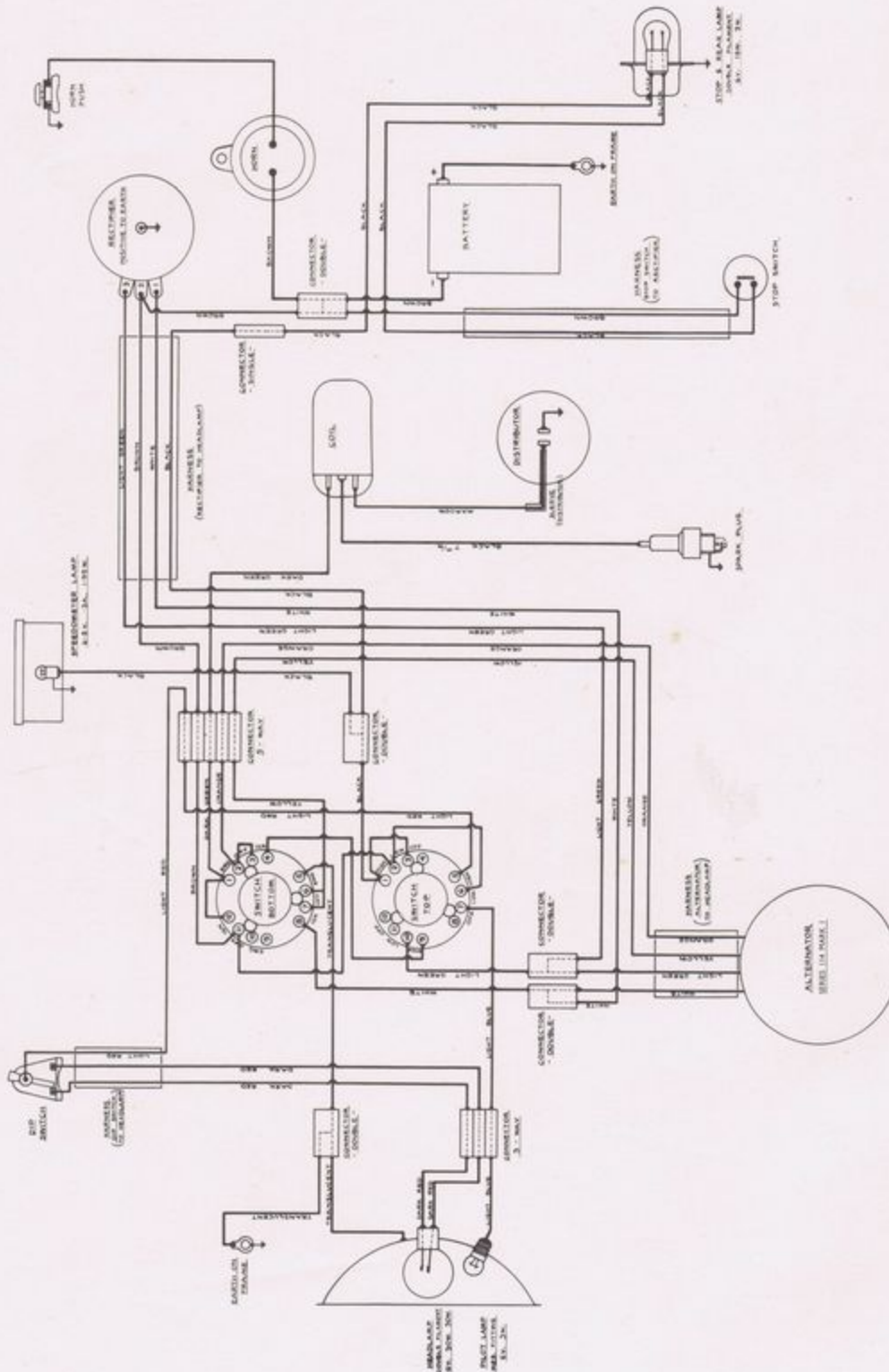

EQUIPMENT	PART No.
HEADLAMP	01980
SWITCH COMPLETE	02098
DIP SWITCH	4-96
ALTERNATOR	01977
DISTRIBUTOR	01811
RECTIFIER	01943
COIL	02760
BATTERY	Varley
	MC5/9
STOP & TAIL LAMP	02300
STOP SWITCH	02228

**THE WIPAC GROUP
BLETCHLEY - ENGLAND**

Telephone:
Bletchley 320

Telegrams:
Wicomagsco Bletchley

PIONEERS OF THE 3/6 SPARK PLUG

REF. WD3.

BARNSTORMERS.CO.NZ

EXCELSIOR "TALISMAN" TWIN EQUIPMENT

CONVERTED TO A.C. LIGHTING

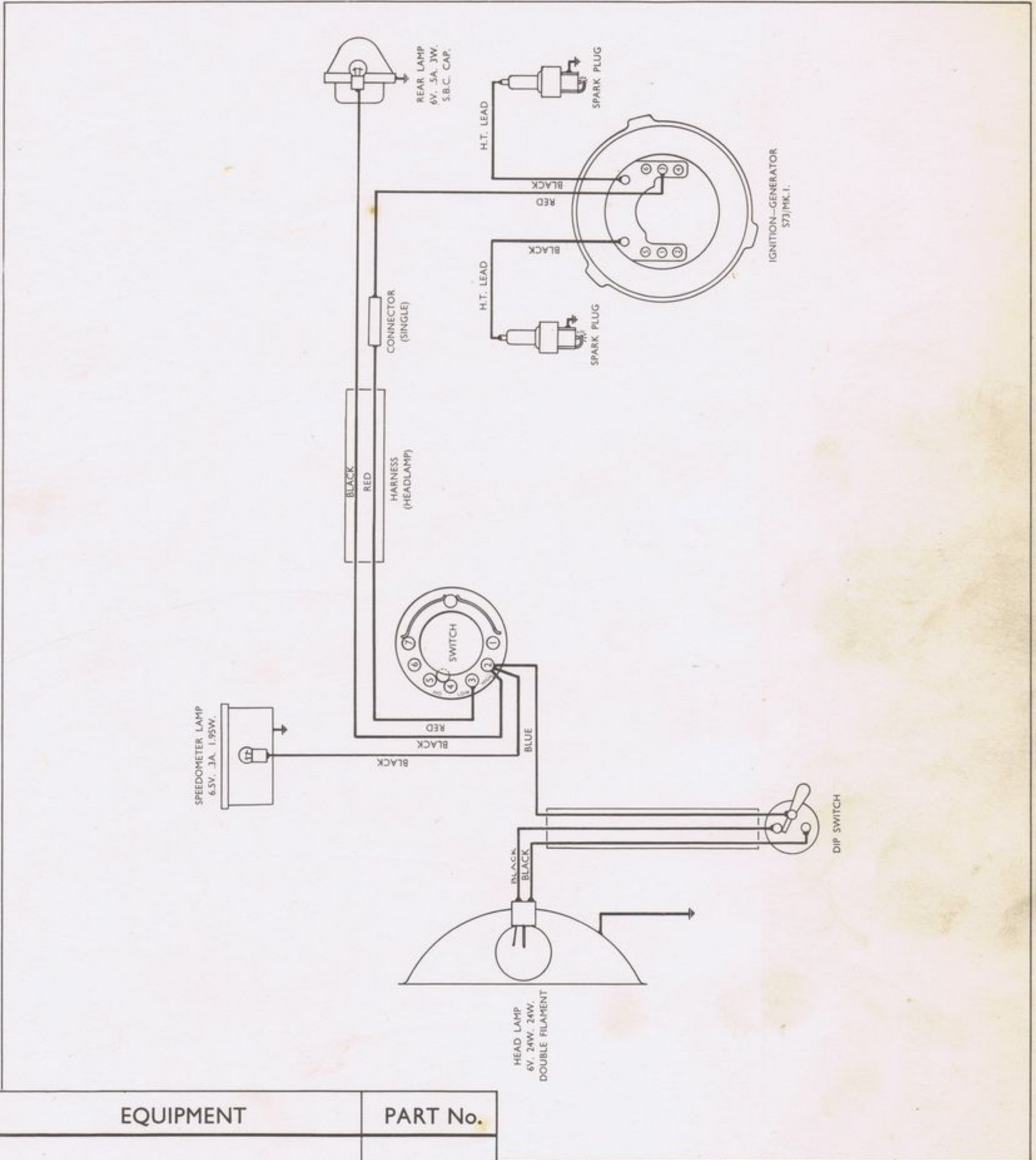

EQUIPMENT	PART No.
IGNITION—GENERATOR	I.G.1100
H.T. LEAD L.H. 20"	X28A—58
H.T. LEAD R.H. 18"	X32B—73

THE WIPAC GROUP
BLETCHLEY - ENGLAND

Telephone: Bletchley 320
 Telegrams: Wicomagsco Bletchley

Ref. W.D.7.